



ELECTRONICS  
DESIGN &  
MANUFACTURING

# ***Solution-16/ Solution-16 Safecom Installation Manual***

ISSUE 2.10







**ELECTRONICS  
DESIGN &  
MANUFACTURING**

**MA880I**

***Solution-16/***

***Solution-16***

***Safecom***

***Installation***

***Manual***

***This page has been included for you to cut out and insert into the spine  
of the folder***

**ISSUE 2.10**



**(61-2) 9672 1777**



# ***Solution-16/Solution-16***

## ***Safecom***

### ***Installation Manual***

Copyright © 1999 by Electronics Design & Manufacturing Pty Limited,  
SYDNEY, AUSTRALIA

**Document Part Number MA880I**  
**Document Issue 2.10**  
**Printed 09/08/99**

**This documentation is provided to suit *Solution-16* Control Panel (CC880/LP880 + SC8016)**  
Firmware Revision 1.10 - 2.02  
Hardware Revision E - K

**This installation manual includes programming locations to suit both Solution-16 (CC880/LP880) and the Solution-16 Safecom (SC8016) control panel. Locations that are only relevant when using the SC8016 are prefixed with the word Safecom.**

#### **Copyright Notice**

All rights reserved. No part of this publication may be reproduced, transmitted or stored in a retrieval system in any form or by any means, electronic, mechanical, photocopying, recording, or otherwise, without the prior written permission of Electronics Design and Manufacturing Pty Limited.

#### **Trademarks**

Throughout this document trademark names may have been used. Rather than put a trademark symbol in every occurrence of a trademark name, we state that we are using the names only in an editorial fashion and to the benefit of the trademark owner with no intention of infringement of the trademark.

#### **Notice of Liability**

While every precaution has been taken in the preparation of this document, neither Electronics Design & Manufacturing Pty Limited nor any of its official representatives shall have any liability to any person or entity with respect to any liability, loss or damage caused or alleged to be caused directly or indirectly by the information contained in this book.

Electronics Design & Manufacturing Pty Limited reserves the right to make changes to features and specifications at any time without prior notification in the interest of ongoing product development and improvement.



# Table Of Contents

<b>INTRODUCTION</b> .....	<b>13</b>
INTRODUCTION .....	14
QUICK START .....	15
TELEPERMIT NOTE .....	16
<b>PROGRAMMING</b> .....	<b>17</b>
PROGRAMMING .....	18
PROGRAMMING WITH THE REMOTE CODEPAD .....	19
PROGRAMMING WITH THE HAND HELD PROGRAMMER .....	20
PROGRAMMING USING THE PROGRAMMING KEY .....	21
PROGRAMMING VIA THE DTMF COMMAND MODULE.....	22
How To Establish A Communication Link With The Control Panel .....	22
Programming The Control Panel Once A Communication Link Has Been Established .....	22
PROGRAMMING OPTION BITS .....	22
INSTALLERS PROGRAMMING COMMANDS .....	23
Command 958 - Enable/Disable Zone Status Mode .....	23
Command 959 - Test Programming Key.....	24
Command 960 - Exit Installer's Programming Mode.....	24
Command 961 - Reset Control Panel Back To Factory Default Settings.....	24
Command 962 - Copy Control Panel Memory To Programming Key .....	25
Command 963 - Copy From Programming Key To Control Panel .....	25
Command 964 - Erase Programming Key.....	26
Command 965 - Set Up Domestic Dialling Format .....	27
Command 966 - Enable/Disable Automatic Stepping Of Locations .....	28
Command 999 - Display Software Version Number.....	28
Disable Factory Default.....	29
DEFAULTING THE CONTROL PANEL .....	29
<b>SYSTEM INDICATORS AND OPERATIONS</b> .....	<b>31</b>
SYSTEM INDICATORS AND OPERATIONS.....	32
The Codepad.....	32
Zone Indicators .....	32
AWAY Indicator.....	32
STAY Indicator .....	32
MAINS Indicator .....	33
FAULT Indicator .....	33
Audible Indicators.....	33
LCD CODEPAD INDICATORS .....	34
SYSTEM OPERATIONS .....	35
Arming The System In AWAY Mode .....	35
Forced Arming .....	35
Disarming The System From AWAY Mode .....	35
Arming The System In STAY Mode 1 .....	36
Forced Arming .....	36
Disarming The System From STAY Mode 1 .....	37
Arming The System In STAY Mode 2 .....	38
Forced Arming .....	38
Disarming The System From STAY Mode 2 .....	39
Codepad Duress Alarm .....	40
Codepad Panic Alarm - Software Version 1.10 - 1.36 .....	40
Codepad Panic Alarm - Software Version 1.37 Onwards .....	40
Codepad Fire Alarm - Software Version 1.37 Onwards.....	40
Codepad Medical Alarm - Software Version 1.37 .....	40
Isolating Zones .....	41
Standard Isolating .....	41
Code To Isolate.....	41

Fault Analysis Mode .....	42
Fault Descriptions .....	42
1 Low Battery .....	42
2 Date and Time .....	42
3 Sensor Watch .....	42
4 Horn Speaker Monitor .....	43
5 Telephone Line Fault .....	43
6 E2 Fault .....	43
7 Zone 16 In Alarm - Partitioned Systems Only .....	43
8 Communication Failure .....	43
AC Mains Failure .....	43
<b>SYSTEM FUNCTIONS.....</b>	<b>45</b>
SYSTEM FUNCTIONS .....	46
Installer Code Functions .....	46
2 Set The Number Of Days Until The First Test Report.....	46
3 Event Memory Recall Mode .....	47
4 Walk Test Mode.....	48
5 Satellite Siren Service Mode.....	48
7 Telephone Monitor Mode On and Off .....	49
Master Code Functions .....	50
0 Arming and Disarming All Areas At The Same Time - Partitioned Systems Only .....	50
1 Changing and Deleting User Codes .....	51
Auxiliary Codes.....	52
2 Programming Domestic Phone Numbers .....	54
3 Event Memory Recall Mode .....	55
4 Walk Test Mode.....	56
5 Turning Outputs On and Off .....	57
6 Setting The Date and Time .....	58
7 Turning Day Alarm On and Off (Software Version 1.10 Only) .....	58
8 Setting STAY Mode 2 Zones .....	59
User Code Functions - Partitioned Systems Only .....	60
0 Arming and Disarming All Areas At The Same Time - Partitioned Systems Only .....	60
Hold Down Functions .....	61
Arm The System In AWAY Mode .....	61
Arm The System In STAY Mode 1 .....	61
Arm The System In STAY Mode 2 .....	61
Horn Speaker Test.....	61
Bell Test .....	62
Strobe Test.....	62
Turning Day Alarm On and Off (New - Software Version 1.20 Onwards) .....	62
Fault Analysis Mode.....	63
Initiate A Modem Call .....	63
Reset Latching Outputs.....	63
Codepad ID and Buzzer Tone Change .....	64
Initiate A Test Report .....	64
<b>REMOTE OPERATIONS .....</b>	<b>65</b>
REMOTE OPERATIONS .....	66
Remote Arming Via The Telephone .....	66
How To Remotely Arm Your System Via The Telephone .....	66
Operating The Control Panel Using The DTMF Command Module .....	67
Operation - Software From Version 1.10 .....	67
Operation - Software From Version 1.20 .....	67
Upload/Download Via Alarm Link Software.....	69
Direct Connect.....	69
Remote Connect .....	70
<b>REPORTING FORMATS.....</b>	<b>71</b>
REPORTING FORMATS .....	72
Contact ID Format .....	72
Event Codes .....	73
Point ID Codes.....	74
General Reporting Formats .....	75
Securitel .....	77



How To Program and Setup Securitel.....	77
Securitel and Partitioning .....	77
Domestic Reporting.....	78
Programming Domestic Reporting.....	78
Domestic Dialling Operation.....	79
Acknowledge Domestic Dialling .....	79
Synthesised Voice Reporting .....	80
How To Set Up The Control Panel For Synthesised Voice Format.....	80
How To Disable Synthesised Voice Dialling Using The Master Code.....	81
Synthesised Voice Dialling Operation.....	81
How To Acknowledge Synthesised Voice Dialling Without DTMF Command Module Fitted .....	81
How To Acknowledge Synthesised Voice Dialling With DTMF Command Module Fitted .....	81
Operation Of The Voice Module.....	82
Recording The Voice Message .....	82
Replay The Voice Message.....	82
Connection Of The Voice Module.....	83
Basic Pager Format Reporting .....	84
PET Alpha Pager Reporting .....	85
Programming and Hardware Requirements .....	85
Telecom Access Telephone Numbers.....	85
PET Alpha Pager Messages .....	86
PET Alpha Pager Password.....	87
Converting ASCII Characters To Hexadecimal.....	88
PET Alpha Pager ID Number.....	88
Logging System Events Via Serial Printer .....	89
Printer Output Baud Rate .....	89
<b>BASE STATION INFORMATION.....</b>	<b>91</b>
BASE STATION INFORMATION.....	92
How To Program A Phone Number.....	92
Primary Telephone Number .....	92
Secondary Telephone Number .....	93
Callback Telephone Number.....	93
Dialling Format .....	93
Handshake Tone.....	94
Transmission Format.....	94
Transmission Speed.....	95
Subscriber ID Number .....	96
Ring Count .....	96
Answering Machine Bypass.....	96
<b>ACCESS CODES .....</b>	<b>97</b>
ACCESS CODES.....	98
Installer Code .....	98
User Codes .....	98
User Code Priority .....	99
Auxiliary Codes.....	101
Auxiliary Code 1 .....	101
Auxiliary Code 2 .....	101
Code Retries.....	101
<b>ZONE PROGRAMMING .....</b>	<b>103</b>
ZONE PROGRAMMING.....	104
Zone Operating Information .....	104
Zone Reporting Information .....	104
Zone Defaults .....	104
Zone Types.....	105
0 Instant Zone.....	105
1 Handover Zone.....	105
2 Delay-1 Zone.....	105
3 Delay-2 Zone.....	105
4 Delay-3 Zone.....	105
5 Delay-4 Zone.....	105
6 Instant Zone + Isolated In STAY Mode 1 .....	105
7 Handover Zone + Isolated In STAY Mode 1 .....	105

8	Delay-1 Zone + Isolated In STAY Mode 1	105
9	Delay-2 Zone + Isolated In STAY Mode 1	106
10	Delay-3 Zone + Isolated In STAY Mode 1	106
11	Delay-4 Zone + Isolated In STAY Mode 1	106
12	24 Hour Burglary Zone	106
13	24 Hour Fire Zone	106
14	Chime Zone (Follow Me)	106
15	Zone Not Used	106
Zone Options		107
1&2	Lockout Siren & Lockout Dialler	107
4	Silent Alarm	107
8	Sensor Watch	108
Zone Pulse Count		108
Zone Pulse Count Handover		109
Zone Pulse Count Time		109
Day Alarm		110
Day Alarm Resetting		110
Day Alarm Latching		110
Day Alarm Operation - (Software Version 1.10)		111
Day Alarm Operation - (Software Version 1.20 Onwards)		111
Day Alarm In Partitioning		111
EOL Resistor Value		112
<b>SYSTEM STATUS INFORMATION</b>		<b>113</b>
SYSTEM STATUS INFORMATION		114
Bypass Codes For Zones 1-8		114
Bypass Codes For Zones 9-16		114
Trouble Codes For Zones 1-8		115
Trouble Codes For Zones 9-16		115
Codepad Duress		116
Codepad Panic		117
Access Denied		118
AC Fail		118
Low Battery		119
Program Altered Code		119
Sensor Watch		120
Open/Close Codes		120
RF Fail		121
Telco Fail		121
RF Jamming		121
Test Reports		122
Test Report Options		122
<b>PROGRAMMABLE OUTPUTS</b>		<b>123</b>
PROGRAMMABLE OUTPUTS		124
Output Configurations		125
Redirecting Outputs To The Codepad Buzzer		126
Safecom Remote Operation Of Outputs		126
Example		126
OUTPUT EVENT TYPES		127
Output Polarity - (Software Version 1.20 - 1.40)		134
0	Output Not Used	134
1	Normally Open, Going Low	134
2	Normally Open, Pulsing Low	134
3	Normally Open, One Shot Low	134
4	Normally Open, One Shot Low With Retrigger	134
5	Normally Open, One Shot Low With Reset	134
6	Normally Open, One Shot Low With Alarm	134
7	Normally Open, Latching Low	134
8	Normally Low, Going Open	135
9	Normally Low, Pulsing Open	135
10	Normally Low, One Shot Open	135
11	Normally Low, One Shot Open With Retrigger	135
12	Normally Low, One Shot Open With Reset	135
13	Normally Low, One Shot Open With Alarm	135

14	Normally Low, Latching Open.....	135
	Output Polarity - (Software Version 1.10 Only).....	135
	Timing Of Outputs.....	136
	Pulsing Polarities.....	136
	One Shot Polarities.....	137
<b>SYSTEM EVENT TIMERS.....</b>		<b>139</b>
SYSTEM EVENT TIMERS.....		140
How To Program Entry/Exit Timers.....		140
Entry Time.....		140
Entry Timer 1.....		140
Entry Timer 2.....		140
Entry Timer 3.....		140
Entry Timer 4.....		140
Exit Time.....		141
Exit Timer For AWAY Mode.....		141
Exit Timer For STAY Mode 1.....		141
Exit Timer For STAY Mode 2.....		141
Entry Guard Timer For STAY Mode.....		141
Codepad Lockout Time.....		142
Sensor Watch Time.....		142
RF Jamming Delay.....		142
RF Supervision Time.....		142
System Date.....		143
Setting The Date and Time.....		143
Auto Arming.....		144
Auto Arming Pre-Alert Timer.....		144
Auto Operation Pre-Alert Timer.....		145
Auto Operation Of The Timed Output.....		145
Siren Run Time.....		145
Siren Sound Rate.....		145
Swinger Shutdown Count.....		146
Swinger Shutdown Count For Siren.....		147
Swinger Shutdown Count For Dialler.....		147
System Time.....		148
Setting The Date and Time.....		148
<b>OPTION BITS.....</b>		<b>149</b>
OPTION BITS.....		150
Dialler Options 1.....		150
Dialler Options 2.....		151
System Options 1.....		152
System Options 2.....		153
System Options 3.....		154
System Options 4.....		155
System Options 4.....		156
Consumer Options 1.....		157
Consumer Options 1.....		158
Consumer Options 2.....		159
DTMF Command Module Options.....		160
Expansion Board Type.....		161
Expansion Board Type.....		162
Telephone Line Fault Options.....		164
Safecom Options.....		165
System Options 5.....		165
System Options 6.....		166
Carrier Sync Options.....		167
<b>PARTITIONING.....</b>		<b>169</b>
PARTITIONING.....		170
Master Partitioned Codepad Indicators.....		170
1 Zone Indicators.....		170
2 Areas On/Off Indicators.....		170
3 Area Display Indicators.....		170
4 Status Indicators.....		170

Operating Codepads In Partitioning.....	171
Operating From A "CP5 Area Addressable (CP500A)" Codepad.....	171
Operating From A "CP5 Master Partitioned (CP500P)" Codepad.....	171
Securitel and Partitioning.....	171
Questions To Be Considered When Partitioning.....	172
Open/Close Reports.....	173
Dialler Options 2.....	173
Open/Close Codes For Area 1.....	174
Open/Close Codes For Area 2.....	174
Open/Close Codes For Area 3.....	174
Open/Close Codes For Area 4.....	174
Subscriber ID Number For Area 1.....	175
Subscriber ID Number For Area 2.....	175
Subscriber ID Number For Area 3.....	175
Subscriber ID Number For Area 4.....	175
Zone Allocations.....	176
Zone Allocations For Area 1.....	176
Zone Allocations For Area 2.....	176
Zone Allocations For Area 3.....	177
Zone Allocations For Area 4.....	177
User Code Allocations.....	178
Setting Up and Programming Codepads For Partitioning.....	179
Codepad Connections For Partitioning.....	180
<b>OPTIONAL EQUIPMENT.....</b>	<b>183</b>
Optional Equipment.....	184
<b>TERMINAL DEFINITIONS AND DESCRIPTIONS.....</b>	<b>191</b>
TERMINAL DEFINITIONS AND DESCRIPTIONS.....	192
Solution-16 Wiring Diagram.....	194
Eight Zone Expansion Board (CC885) - Fixed 3K3 EOL Resistors.....	195
Eight Zone Expansion Board (CC883) - Variable EOL Resistors.....	195
Connections Of Split EOL Resistors For 16 Zone Operation.....	196
Eight Channel Open Collector Output Board (CC884).....	196
Connection For Momentary Or Latching Keyswitch.....	197
Connections For 25 Pin Logging Printer.....	197
Connections For 9 Pin Logging Printer.....	197
Solution-16 Component Overlay.....	198
Solution-16 Safecom Interface.....	199
<b>Figure 23: Solution-16 Safecom Interface</b> .....	199
How to Install the BNC Fitting.....	199
How to Mount the Radio.....	200
Mounting the Radio.....	200
Telecom Connection Diagrams.....	201
<b>APPENDICES.....</b>	<b>203</b>
APPENDIX A.....	204
Telephone Anti-Jamming.....	204
APPENDIX B.....	205
Test Reports Only When Armed.....	205
<b>SPECIFICATIONS.....</b>	<b>207</b>
WARRANTY STATEMENT.....	208
Specifications.....	208
Software Version Number.....	208
<b>PROGRAMMING SHEETS.....</b>	<b>209</b>
<b>INDEX.....</b>	<b>219</b>

# ***Introduction***

---

***This Section Includes The Following:***

- *Introduction*
- *Quick Start*
- *Telepermit Note*

## **Introduction**

Congratulations on selecting the *Solution-16* control panel for your installation. So that you can obtain the most from your unit, we suggest that you take the time to read through this manual and familiarise yourself with the numerous outstanding operating and installation features of this control panel.

You will notice that in all aspects of planning, engineering, styling, operation, convenience and adaptability, we have sought to anticipate your every possible requirement. Programming simplicity and speed have been some of the major considerations and we believe that our objectives in this area have been more than satisfied.

This installation manual will explain all aspects of programming the *Solution-16* control panel from factory default to final commissioning. All system parameters and options are detailed, however, suitability is left up to the individual. Every control panel can be tailored to meet all requirements quickly and easily. The programming simplicity will make your installation quick, accurate and rewarding each and every time.

The *Solution* range of control panels has proven very popular amongst thousands of people throughout many countries of the world, all who have various levels of technical aptitude and ability. We have tried to aim this installation manual to all levels of readers.

As the *Solution* control panels have continued to advance over the years, they have become very powerful and extensive. Some of its early first-time users have advanced to true "power users" and we need to address their needs too, while maintaining the simplicity of the manual and the product.

## Quick Start

The following steps will enable you to use the *Solution-16* control panel with the factory default values.

1. Connect the AC plug pack to the control panel.

All zone indicators on the remote codepad will illuminate momentarily and then extinguish. Check the operation of the overload LED (LD1) on the printed circuit board. In normal operation the LED will not illuminate. The MAINS indicator will remain on as will the AWAY indicator. The system is now in the armed state.

2. The lead acid back-up battery should now be connected. The lead acid rechargeable back-up battery should be rated at 12v DC @ 6.5 Ah.
3. Enter the **MASTER CODE** followed by the **AWAY** button to disarm the system. The AWAY indicator will extinguish. The control panel is now in the disarmed state. Programming of the control panel can now be accessed. Refer to the "Master Code Functions" on page 50 for more information. The factory default Master Code is **2580**.
4. Enter the factory default **INSTALLER CODE** followed by the **AWAY** button to access the Installer's Programming Mode. The STAY and AWAY indicator's will now flash simultaneously. Refer to "LOCATION 56 - 62" on page 98 for the locations of the factory default Installer Code. The factory default Installer Code is **1234**.
5. Enter the Primary Telephone Number and the Secondary Telephone Number followed by the Subscriber ID Number.
6. If required, program the test reporting time and any other programming changes to be made, otherwise the programmed factory default settings will be used.
7. Enter command **960** followed by the **AWAY** button to exit the Installer's Programming Mode. The control panel will return to the disarmed state and is now ready for use.
8. Refer to page 42 for information on any system faults that may have occurred.
9. Using a Master Code set the date and time. Refer to "Master Code Functions" on page 50 for more information on setting the date and time.

Zone Number	Zone Type
1	Delay-1
2, 3, 4, 5	Handover
6, 7 & 9 - 16	Instant
8	24 Hour

*Table 1: Zone Defaults*

The factory default settings allow the control panel to communicate in Contact ID Format operating eight zones. For further information on the factory default settings, refer to the "Programming Sheets" on page 209 at the back of the installation manual. If sixteen zones are required, refer to "LOCATION 339" on page 112 for setting the split EOL resistor value or "LOCATION 672" to enable the zone expansion board if required on page 161.

## Telepermit Note

The grant of a Telepermit for a device in no way indicates Telecom acceptance of responsibility for the correct operation of that device under all operating conditions.

This equipment shall not be used in any manner that could constitute a nuisance to other Telecom customers.

Immediately disconnect this equipment should it become physically damaged, and arrange for its disposal or repair.

The preferred method of dialling is to use DTMF tones as this is faster than pulse (Decadic) dialling. In some situations there may be difficulties with DTMF signalling as this control panel is not fully compatible with the Telecom Telephone Network. In this case you must use decadic dialling, and your control panel must be set up to record numbers using the following translation table as it does not implement the New Zealand "Reverse Dialling" standard.

Number to be dialled	0	1	2	3	4	5	6	7	8	9
Number to be programmed	9	8	7	6	5	4	3	2	1	0

Note that where DTMF dialling is used, the numbers should be entered normally.

The transmit level from this device is set as a fixed level and because of this there may be circumstances where the performance is less than optimal. Before reporting such occurrences as faults, please check the line with a standard telepermitted telephone.



# Programming

---

## **This Section Includes The Following:**

- *Programming*
- *Programming With The Remote Codepad*
- *Programming With The Hand Held Programmer*
- *Programming Using The Programming Key*
- *Programming Via The DTMF Command Module*
- *Programming Option Bits*
- *Installers Programming Commands*
- *Disable Factory Default*
- *Defaulting The Control Panel*

## **Programming**

The programming options of this control panel are stored in a non volatile EEPROM. This memory will hold all the relevant configuration and user specific data even during a total power loss.

The data retention time is as long as ten years without power, therefore, no reprogramming will be required after powering the control panel down.

The data can be altered as many times as required without the need for any additional specialised equipment. This memory is laid out in numerous locations, each of which holds the data for a specific function.

In general, the entire programming sequence will consist of nominating the location number required and then entering or altering the data. You will repeat this procedure until all the data has been programmed to suit your requirements. The factory default settings have been selected for reporting in the Contact ID Format.

---

**Note: 15 is the maximum value that can be programmed into any location.**

---

There are two programming modes. The Installer's Programming Mode and the Operators Programming Mode. Both programming modes have individual access codes and these two codes must always be programmed differently. The Master Code, as well as being able to arm and disarm the system gives access to the Operators Programming Mode. The Installers Code only gives access to the Installer's Programming Mode and does NOT arm and disarm the system.

Programming of the *Solution-16* control panel can be carried out via any of the following five methods.

- ◆ System Codepad
- ◆ Hand Held Programmer (CC814)
- ◆ Programming Key (CC891)
- ◆ Alarm Link Upload/Download Software (CC816)
- ◆ DTMF Command Module (CC886)

## Programming With The Remote Codepad

The control panel must be in the disarmed state with no flashing zone alarm memories to access the Installer's Programming Mode. This can be achieved by entering the **MASTER CODE** followed by the **AWAY** button. The factory default Master Code is **2580**.

To access the Installer's Programming Mode, enter the **INSTALLER CODE** followed by the **AWAY** button. The factory default Installer Code is **1234**. Three beeps will be heard and both the STAY and AWAY indicators will flash simultaneously. If a long beep is heard, check the control panel for alarm memory. The combination of the MAINS and ZONE indicators will indicate the data stored in the first location of the Primary Telephone Number (LOCATION 000).

Data Value	Zone 1 Indicator	Zone 2 Indicator	Zone 3 Indicator	Zone 4 Indicator	Zone 5 Indicator	Zone 6 Indicator	Zone 7 Indicator	Zone 8 Indicator	MAINS Indicator
0									
1	✓								
2		✓							
3			✓						
4				✓					
5					✓				
6						✓			
7							✓		
8								✓	
9	✓							✓	
10									✓
11	✓								✓
12		✓							✓
13			✓						✓
14				✓					✓
15					✓				✓

Table 2: Zone Indicators When Programming

### Example

To enter Installer's Programming Mode, enter the **INSTALLER CODE** followed by the **AWAY** button. The factory default Installer's Code is **1234**. Two beeps will be heard and the codepad will display the current data stored in "LOCATION 000".

To go to a particular location, enter the **LOCATION NUMBER** required followed by the **AWAY** button. The data of the new location will now be displayed.

To move to the next location, press the **AWAY** button. This will step you to the next location and the data in that location will be displayed via the ZONE indicators.

If you press the **STAY** button without previously entering a location number, the system will step back one location. To change data at the current location, enter the new value (0-15) followed by the **STAY** button. This will store the new data into the location and still leave you positioned at the same location.

To proceed to the next location, press the **AWAY** button. The next locations data will now be displayed.

To exit the Installer's Programming Mode, enter command **960** followed by the **AWAY** button. Two beeps will be heard and the system will return back to normal operation. Refer to "Installers Programming Commands" on page 23 for further information on commands that can be performed during access of the Installer's Programming Mode.

## Programming With The Hand Held Programmer

The Hand Held Programmer (CC814) has five, seven segment displays. The three on the left display the location number, and the two on the right display the data for that particular location.

To connect the hand held programmer, locate the connections marked PROGRAMMING KEY. This point can be found on the left hand side of the *Solution-16* printed circuit board. Observe the triangular markings on the *Solution-16* printed circuit board and line them up with the markings on the hand held programmers connecting socket.

When the hand held programmer is correctly plugged onto the printed circuit board, one beep will be heard and four centre bars on the hand held programmer will illuminate with either an 'A' or 'U' suffix to indicate the system is armed or unarmed. Only when the Installer's Programming Mode has been accessed will any numerals appear on the display.

---

**Note:** When connecting the hand held programmer to the control panel, make sure that the switch on the hand held programmer is in the EXT position and that no external programming key has been connected. Failing to do this may corrupt the control panel's memory. If this happens, the control panel will need to be returned to Electronics Design and Manufacturing Pty Limited where a service fee will be charged to unlock the control panel's memory.

---

### Example

To enter the Installer's Programming Mode, enter the  followed by the  button. The factory default Installers Code is . Two beeps will be heard and the hand held programmers display will show the current data stored in "LOCATION 000".

To move to a particular programming location, enter the  followed by the  button. The data for the new location will now be displayed.

To move to the next location press the  button. This will step you to the next location and the data in that location will now be displayed via the ZONE indicators.

If you press the  button without previously entering a location number, the system will step back one location. To change data in the current location, enter the new value (0-15) followed by the  button. This will store the new data into the location and still leave you still positioned at the same location.

To proceed to the next location, press the  button. The next locations data will now be displayed.

To exit the Installer's Programming Mode, enter command  followed by the  button. Two beeps will be heard and the system will return back to normal operation. Refer to "Installers Programming Commands" on page 23 for further information on commands that can be performed during access of the Installer's Programming Mode.

---

**Note:** When using the hand held programmer, any reference in this manual made to the  button should be considered as the  button and the  button considered as the  button.

---

## **Programming Using The Programming Key**

The Programming Key (CC891) is a unique device that will allow you to easily program your control panel. Inserting the programming key will automatically initiate a data transfer from the programming key to the control panel memory.

If you have a new programming key, you should first enter the Installer's Programming Mode, configure your control panel as per your requirements before inserting the programming key.

To connect the programming key, locate the connections marked PROGRAMMING KEY. This point can be found on the right hand side of the control panel. Observe the triangular markings on the printed circuit board and line them up with the markings on the programming key.

To copy the control panel's data into your new programming key, enter command **962** followed by the **AWAY** button. Refer to "Command 962 - Copy Control Panel Memory To Programming Key" on page 25 for further details.

Exit the Installer's Programming Mode by entering the command **960** followed by the **AWAY** button, wait two seconds for the activity LED to return to its normal state and then remove the programming key. This programming key will now become your standard data pattern for future programming of your control panels.

It should be noted that when entering the Installer's Programming Mode, inserting a programming key and then altering any location will cause a simultaneous update of not only the programming keys data, but also the control panels data. Therefore, you are not able to alter data in the programming key without the same location being altered in the control panels memory.

---

**Note:** Connecting a Programming Key (CC891) to the control panel when the programming keys memory is blank will corrupt the control panel's memory unless the Installer's Programming Mode has been entered first. If this occurs, then the control panel will need to be returned to Electronics Design & Manufacturing Pty Limited where a service fee will be charged to unlock the control panel's memory.

---

## Programming Via The DTMF Command Module

The DTMF Command Module (CC886) will allow you to operate and program your control panel remotely via the telephone line. Once a communications link has been established with the control panel, you will be able to perform any system functions using the codepad on a touch tone telephone for Master Code, User Code and Installer Code Functions as well as access into Installer's Programming Mode.

Below will give an example of making a connection to the control panel and changing the "Exit Time" for AWAY Mode to 26 seconds on a non partitioned system. To connect to a system, which has been partitioned, refer to "Operating The Control Panel Using The DTMF Command Module" on page 67 for further information.

### Example

### How To Establish A Communication Link With The Control Panel

1. Dial the telephone number that the control panel has been connected to. When the control panel answers your call, you will hear a short jingle.
2. After the jingle, press the **[0]** button on the telephone. You will now hear a second jingle and have established a communication link with the control panel.

### Programming The Control Panel Once A Communication Link Has Been Established

Once the connection has been established, enter your **[INSTALLER CODE]** followed by the **[#]** button. Two beeps will be heard. If no beeps are heard, enter a user code to disarm the system before entering the Installer's Code again.

After entering Installer's Programming Mode, follow the steps below to program the new "Exit Time " for AWAY Mode.

1. To go to "LOCATION 632", enter **[6][3][2]** followed by the **[#]** button.
2. Enter the value **[10]** followed by the **[\*]** button.
3. Press the **[#]** button to move to the next location.
4. Enter the value **[1]** followed by the **[\*]** button.
5. Now enter command **[9][6][0]** followed by the **[#]** button to exit Installer's Programming Mode. The exit time for AWAY Mode has now been programmed for 26 seconds.

To terminate the communication link with the control panel, press the **[#]** button twice.

## Programming Option Bits

When programming these locations you will notice that there are four alternatives per location. You may select one, two, three or all of these alternatives for each location, however, only one number is required to be programmed. This number is calculated by adding the option bit numbers together.

### Example

If at "LOCATION 663" you want options 1, 2 and 4. Add the numbers together and the total is the number to be programmed. In this example, the number to be programmed is 7 (ie. 1+2+4=7).

Option	Description
1	Enable Dialler Reporting Functions
2	Enable Remote Arming Via The Telephone
4	Enable Upload/Download
8	Terminate Alarm Link Session On Alarm

Table 3: Example - Programming Option Bits

## Installers Programming Commands

There are several commands that can be invoked to perform various functions once the Installer's Programming Mode has been entered. To invoke the command, enter the corresponding numerical code followed by the **AWAY** button

Command	Function
958	Enable and Disable Zone Status Mode
959	Test Programming Key
960	Exit Installer's Programming Mode
961	Reset Control Panel Back To Factory Default Settings
962	Copy The Control Panel Memory To The Programming Key
963	Copy The Programming Key Data To The Control Panel
964	Erase Programming Key
965	Set Up Domestic Dialling Format
966	Enable and Disable Automatic Stepping Of Locations During Programming
999	This Command Displays The Control Panel's Software Version Number Only When Using The Hand Held Programmer

Table 4: Installer's Programming Commands

### Command 958 - Enable/Disable Zone Status Mode

This function enables and disables the zone status display mode. When using the hand held programmer, the zones will be displayed on the seven segment displays from left to right. If there is a dash illuminated on the display, the corresponding zone is unsealed and if the display is blank, the zone is sealed.

The third (or centre) display shows either the number 4 or the number 8. The number 4 constantly illuminated indicates that zones 1 - 4 are being displayed. The number 8 constantly illuminated indicates that zones 5 - 8 are being displayed. The number 4 flashing indicates zones 9 - 12 are being displayed. The number 8 flashing indicates that zones 13 - 16 are being displayed.

Pressing the **#** button will toggle the display between the zones. This feature will prove to be very useful during installation as it allows you to view the status of the zones directly at the control panel, saving you time and money.

#### How To Enable Zone Status Mode

1. Enter Installers Programming Mode.
2. Enter command **958** followed by the **#** button.  
Two beeps will be heard.

#### How To Disable Zone Status Mode

1. Enter command **958** followed by the **#** button.  
Two beeps will be heard.

#### Example

A " - " in the display indicates the zone is triggered.

A blank display indicates the zone is normal.

**- - 4 - -** indicates that zones 1, 2, 3 and 4 are triggered.

A flashing "4" indicates zones 9, 10, 11 and 12 are being displayed.

**- - 8 - -** indicates that zones 5 and 8 are triggered.

A flashing "8" indicates zones 13 and 16 are being displayed.

### **Command 959 - Test Programming Key**

This command causes a test to be carried out on the programming key. This test is non destructive and any data in the programming key will remain intact after the test has been completed. One long beep indicates that the programming key has failed and three beeps indicates a successful test. If the programming key has been removed before the test has completed or the programming key has failed, the data in the programming key has become corrupt. Remember, do not remove the programming key while the activity LED is illuminated constantly or pulsing rapidly.

#### **How To Test The Programming Key**

1. Enter Installer's Programming Mode.
2. Plug the programming key onto the pins marked PROGRAMMING KEY on the control panel.
3. Enter command **959** followed by the **#** button.  
Two beeps will be heard and the programming key has now been tested.
4. Enter command **960** followed by the **#** button to exit the Installer's Programming Mode before removing the programming key.

#### **How To Test The Programming Key Using The Hand Held Programmer**

1. Before connecting the hand held programmer, make sure that the switch on the hand held programmer is in the EXT position.
2. Enter the Installer's Programming Mode.
3. Plug the programming key onto the pins marked EXTERNAL KEY on the hand held programmer.
4. Enter command **959** followed by the **#** button.  
Two beeps will be heard and the programming key connected to the hand held programmer has now be tested.
5. Enter command **960** followed by the **#** button to exit the Installer's Programming Mode.
6. Leave the switch on the hand held programmer in the EXT position and disconnect the external programming key.

### **Command 960 - Exit Installer's Programming Mode**

This command is used to exit the Installer's Programming Mode after you complete your programming alterations. This is achieved by entering command **960** followed by the **#** button. Two beeps will be heard and the system will return to normal. This command can be performed at any programming stage and from any location.

### **Command 961 - Reset Control Panel Back To Factory Default Settings**

This command will reset the control panel back to the factory default values. Refer to the values shown throughout this manual or the "Programming Sheets" on page 209. This is achieved by entering the command **961** followed by the **#** button. Three beeps will be heard.



## **Command 962 - Copy Control Panel Memory To Programming Key**

This command is used to copy the control panel memory to the programming key.

### **How To Copy The Control Panel Memory To The Programming Key**

1. Enter Installer's Programming Mode.
2. Plug the programming key onto the pins marked PROGRAMMING KEY on the control panel.
3. Enter command **962** followed by the **#** button.  
Two beeps will be heard and the control panel's memory has now been copied into the programming key.
4. Enter command **960** followed by the **#** button to exit the Installer's Programming Mode.
5. Disconnect the programming key from the control panel.

### **How To Copy The Control Panel Memory To The Programming Key Using The Hand Held Programmer**

1. Before connecting the hand held programmer to the control panel, make sure that the switch on the hand held programmer is in the EXT position.
2. Enter the Installer's Programming Mode.
3. Plug the programming key onto the pins marked EXTERNAL KEY on the hand held programmer.
4. Enter command **962** followed by the **#** button.  
Two beeps will be heard and the control panel's memory has now been copied into the programming key.
5. Enter command **960** followed by the **#** button to exit the Installer's Programming Mode.
6. Leave the switch on the hand held programmer in the EXT position and disconnect the programming key.

## **Command 963 - Copy From Programming Key To Control Panel**

This command is used to copy data from the programming key to the control panel.

### **How To Copy The Programming Key Memory To The Control Panel**

1. Enter Installer's Programming Mode.
2. Connect the programming key onto the pins marked PROGRAMMING KEY on the control panel.
3. Enter command **963** followed by the **#** button.  
Two beeps will be heard and the programming key's data has now been copied to the control panel.
4. Enter command **960** followed by the **#** button to exit Installer's Programming Mode.
5. Now disconnect the programming key from the control panel.

### **How To Copy The Programming Key Memory To The Control Panel Using The Hand Held Programmer**

1. Before connecting the hand held programmer to the control panel, make sure that the switch on the hand held programmer is in the EXT position.
2. Enter the Installer's Programming Mode.
3. Plug the programming key onto the pins marked EXTERNAL KEY on the hand held programmer.
4. Enter command **963** followed by the **#** button.  
Two beeps will be heard and the programming keys data will now be copied to the control panel.
5. Enter command **960** followed by the **#** button to exit the Installer's Programming Mode.
6. Leave the switch on the hand held programmer in the EXT position and disconnect the programming key.

## **Command 964 - Erase Programming Key**

This command erases all data from the programming key.

### **How To Erase The Programming Key**

1. Enter the Installer's Programming Mode.
2. Connect the programming key onto the pins marked PROGRAMMING KEY on the control panel.
3. Enter command **964** followed by the **#** button.
4. Two beeps will be heard and the programming keys data has now been deleted.
5. Enter command **960** followed by the **#** button to exit the Installer's Programming Mode.
6. Now remove the programming key from the control panel.

### **How To Erase The Programming Key Using The Hand Held Programmer**

1. Before connecting the hand held programmer to the control panel, make sure that the switch on the hand held programmer is in the EXT position.
2. Enter the Installer's Programming Mode.
3. Plug the programming key onto the pins marked EXTERNAL KEY on the hand held programmer.
4. Enter command **964** followed by the **#** button.  
Two beeps will be heard and the programming keys data has now been deleted.
5. Enter command **960** followed by the **#** button to exit Installer's Programming Mode.
6. Now disconnect the programming key from the hand held programmer.

## Command 965 - Set Up Domestic Dialling Format

Command 965 has been added to make the set up of the Domestic Dialling Format a one step operation. Refer to page 78 for more information on "Domestic Reporting".

After Installer's Programming Mode has been accessed, enter command **965** followed by the **#** button. This will automatically set the following locations in bold below. No other locations will be altered when command 965 has been issued.

<b>Location</b>	<b>Description</b>	<b>Setting</b>
<b>Location 49</b>	Handshake Tone	<b>2</b> (1400 Hz)
<b>Location 50</b>	Transmission Format	<b>11</b> (Domestic Dialling)
<b>Location 52 - 55</b>	Subscriber ID Number	<b>0, 0, 0, 1</b>
<b>Location 340 - 347</b>	Zone 1	<b>2, 0, 0, 0, 0, 3, 0, 1</b> (Delay-1)
<b>Location 348 - 355</b>	Zone 2	<b>1, 0, 0, 0, 0, 3, 0, 1</b> (Handover)
<b>Location 356 - 363</b>	Zone 3	<b>1, 0, 0, 0, 0, 3, 0, 1</b> (Handover)
<b>Location 364 - 371</b>	Zone 4	<b>1, 0, 0, 0, 0, 3, 0, 1</b> (Handover)
<b>Location 372 - 379</b>	Zone 5	<b>1, 0, 0, 0, 0, 3, 0, 1</b> (Handover)
<b>Location 380 - 387</b>	Zone 6	<b>0, 0, 0, 0, 0, 3, 0, 1</b> (Instant)
<b>Location 388 - 395</b>	Zone 7	<b>0, 0, 0, 0, 0, 3, 0, 1</b> (Instant)
<b>Location 396 - 403</b>	Zone 8	<b>12, 0, 0, 0, 0, 3, 3, 1</b> (24 Hour Burglary)
<b>Location 404 - 411</b>	Zone 9	<b>0, 0, 0, 0, 0, 3, 0, 1</b> (Instant)
<b>Location 412 - 419</b>	Zone 10	<b>0, 0, 0, 0, 0, 3, 0, 1</b> (Instant)
<b>Location 420 - 427</b>	Zone 11	<b>0, 0, 0, 0, 0, 3, 0, 1</b> (Instant)
<b>Location 428 - 435</b>	Zone 12	<b>0, 0, 0, 0, 0, 3, 0, 1</b> (Instant)
<b>Location 436 - 443</b>	Zone 13	<b>0, 0, 0, 0, 0, 3, 0, 1</b> (Instant)
<b>Location 444 - 451</b>	Zone 14	<b>0, 0, 0, 0, 0, 3, 0, 1</b> (Instant)
<b>Location 452 - 459</b>	Zone 15	<b>0, 0, 0, 0, 0, 3, 0, 1</b> (Instant)
<b>Location 460 - 467</b>	Zone 16	<b>0, 0, 0, 0, 0, 3, 0, 1</b> (Instant)
<b>Location 468 - 471</b>	Bypass Reports	<b>0, 0, 0, 0</b> (Not Used)
<b>Location 472 - 475</b>	Trouble Reports	<b>0, 0, 0, 0</b> (Not Used)
<b>Location 476 - 479</b>	Codepad Duress	<b>0, 0, 0, 0</b> (Not Used)
<b>Location 480 - 483</b>	Codepad Panic	<b>0, 0, 0, 0</b> (Not Used)
<b>Location 484 - 487</b>	Codepad Tamper	<b>0, 0, 0, 0</b> (Not Used)
<b>Location 488 - 491</b>	AC Fail	<b>0, 0, 0, 0</b> (Not Used)
<b>Location 492 - 495</b>	Low Battery	<b>0, 0, 0, 0</b> (Not Used)
<b>Location 496 - 499</b>	Program Altered	<b>0, 0, 0, 0</b> (Not Used)
<b>Location 500 - 503</b>	Sensor Watch	<b>0, 0, 0, 0</b> (Not Used)
<b>Location 504 - 505</b>	Open/Close Reports	<b>0, 0</b> (Not Used)
<b>Location 506 - 513</b>	Test Report Time	<b>0, 0, 0, 0, 0, 0, 9, 0</b> (Not Used)

*Table 5: Command 965 Defaults*

As you can see from the table above, all reporting other than zone alarms have been disabled. The handshake tone has been set for 1400 Hz tone acknowledgment and the Subscriber ID Number has been set for one identification beep. The zone reporting has been set so that any zone that triggers into alarm condition will only report when the alarm occurs, the zone restore report will not report as there is no separate indications for zone alarm reports and zone alarm restore reports.

---

**Note: From Software Version 1.30, Command 965 disables zone restore reports.**

---

## Command 966 - Enable/Disable Automatic Stepping Of Locations

This command enables or disables the automatic stepping of locations while programming. When enabled via the hand held programmer, the decimal point of the left most display will reflect the mode of operation.

If the decimal point is illuminated then auto step mode is active. An automatic increment of the location being programmed will occur as soon as the **\*** button is pressed positioning you at the next location ready for programming.

If the decimal point is extinguished, the auto step mode is disabled. The next programming location will need to be manually selected by pressing the **#** button. As you can see from the examples below, auto step mode is a very useful feature when programming successive locations.

### How To Enable Automatic Stepping Of Locations

1. Enter command **966** followed by the **#** button.  
Two beeps will be heard.

### How To Disable Automatic Stepping Of Locations

1. Enter command **966** followed by the **#** button.  
Two beeps will be heard.

### Example

(Auto Step Enabled)

To enter the Primary Telephone Number "02 pause 9 672 1055" with auto step enabled (ie. Decimal point illuminated).

Press **0** followed by the **#** button.

(This will position you at "LOCATION 000" being the start of the Primary Telephone Number).

**10** + **\*** + **2** + **\*** + **13** + **\*** + **9** + **\*** + **6** + **\*** + **7** + **\*** + **2** +  
**\*** + **1** + **\*** + **10** + **\*** + **5** + **\*** + **5** + **\*** + **0** + **\***

### Example

(Auto Step Disabled)

To enter the Primary Telephone Number "02 pause 9 672 1055" with auto step disabled (ie. Decimal point extinguished).

Press **0** followed by the **#** button.

(This will position you at "LOCATION 000" being the start of the Primary Telephone Number).

**10** + **\*** + **#** + **2** + **\*** + **#** + **13** + **\*** + **#** + **9** + **\*** + **#** + **6** +  
**\*** + **#** + **7** + **\*** + **#** + **2** + **\*** + **#** + **1** + **\*** + **#** + **10** + **\*** +  
**#** + **5** + **\*** + **#** + **5** + **\*** + **#** + **0** + **\***

## Command 999 - Display Software Version Number

This command will display the control panel's software version number. This command can only be used with the hand held programmer.

Enter command **999** followed by the **#** button to display the control panel's software version number. Two beeps will be heard. Press the **#** button to exit this command.

**LOCATION 900**

The system has a feature that prevents the control panel from being manually defaulted via the default button or by using a programming key.

Any number between 0-14 programmed into this location will allow defaulting of the control panel. If 15 has been programmed into this location, defaulting of the control panel will not operate and the Installer Code MUST be used for further programming of the control panel.

If the Installer Code is not known, the control panel will need to be returned to your EDM Distributor for exchange. A nominal fee applies for this service.

---

**Warning: Electronics Design and Manufacturing Pty Limited does not recommend the use of this feature.**

---

If this option is required, a special programming procedure has been introduced to eliminate any possibility of accidentally setting this option. The default button on the PCB must be held down while programming this location.

**How To Prevent Manual Defaulting Of The Control Panel**

1. Plug the hand held programmer to the pins provided on the PCB.
2. Disarm the system.
3. Access Installer's Programming Mode.
4. Go to "LOCATION 900".
5. Hold down the default button.
6. Program a 15 into "LOCATION 900".
7. Release the default button.
8. Exit Installer's Programming Mode.

**Defaulting The Control Panel**

If the *Solution-16* control panel does not have "LOCATION 900" programmed as 15, follow the procedure outlined below to successfully default the control panel back to the factory default settings.

**How To Default The Control Panel**

1. Disconnect the AC mains and backup battery from the control panel.
2. Hold down and continue to hold down the DEFAULT button located at the top of the printed circuit board.
3. Reconnect the AC mains to the control panel.
4. After reconnecting the AC mains, wait for 3-5 seconds before releasing the DEFAULT button.

You will hear the dialler seize relay (RL2) on the control panel click once and two beeps will be heard on the remote codepad. The control panel will now need to be disarmed by using the default Master Code 2580.

The control panel has now been successfully defaulted back to the factory default settings.

---

**Note: If following the above procedure to default the control panel and you hear the dialler seize relay (RL2) click four times, defaulting the control panel has been disabled. The control panel will need to be returned to Electronics Design and Manufacturing Pty Limited for exchange where a service fee will be charged to unlock the control panel's memory.**

---



# ***System Indicators and Operations***

---

## **This Section Includes The Following:**

- *The Codepad*
- *Zone Indicators*
- *AWAY Indicator*
- *STAY Indicator*
- *MAINS Indicator*
- *FAULT Indicator*
- *Audible Indicators*
- *LCD Codepad Indicators*
- *Arming The System In AWAY Mode*
- *Disarming The System From AWAY Mode*
- *Arming The System In STAY Mode 1*
- *Disarming The System From STAY Mode 1*
- *Arming The System In STAY Mode 2*
- *Disarming The System From STAY Mode 2*
- *Codepad Duress Alarm*
- *Codepad Panic Alarm*
- *Codepad Fire Alarm*
- *Codepad Medical Alarm*
- *Isolating Zones*
- *Fault Analysis Mode*

# System Indicators and Operations

## The Codepad

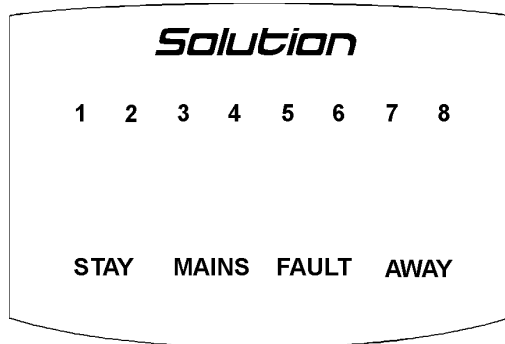

Figure 1: CP5 Eight Zone Codepad

The codepad is the communications interface between you and your alarm system. It allows you to issue commands and offers both visual and audible indications that guide you through the general operation.

The codepad incorporates numerous indicators. There are ZONE indicators which are used to show the condition of each zone and four others for general status. The following is a list of situations and the relevant indications that will be seen.

## Zone Indicators

The ZONE indicators are used to show the status of the zones. The following table list the various circumstances that the indicators will display (ie. Zone Sealed, Zone Unsealed).

Indicator	Definition
On	Zone Is Unsealed
Off	Zone Is Sealed
Flashing Fast (0.25 Sec On - 0.25 Sec Off)	Zone Is In Alarm Condition
Flashing Slow (1 Sec On - 1 Sec Off)	Zone Is Manually Isolated

Table 6: Zone Indicators

## AWAY Indicator

The AWAY indicator is used to inform you that the system is armed in the AWAY Mode.

Indicator	Definition
On	System Is Armed In AWAY Mode
Off	System Is Not Armed In AWAY Mode

Table 7: AWAY Indicator Functions

## STAY Indicator

The STAY indicator is used to indicate that the system is armed in STAY Mode 1 or STAY Mode 2.

Indicator	Definition
On	System Is Armed In STAY Mode 1 Or STAY Mode 2
Off	System Is Not Armed In STAY Mode 1 Or STAY Mode 2
Flashing	System Is In ISOLATE Mode Or STAY Mode 2 Zones Are Being Programmed

Table 8: STAY Indicator Functions



## **MAINS Indicator**

The MAINS indicator is used to indicate that the systems AC mains power is normal or has failed.

<b>Indicator</b>	<b>Definition</b>
<b>On</b>	AC Mains Power Normal
<b>Flashing</b>	AC Mains Failure

*Table 9: MAINS Indicator Function*

## **FAULT Indicator**

The FAULT indicator is used to indicate that the system has detected a system fault. Refer to "Fault Analysis Mode" on page 42 for more details on system faults.

<b>Indicator</b>	<b>Definition</b>
<b>On</b>	There Is A System Fault That Needs To Be Rectified
<b>Off</b>	The System Is Normal, There Are No Faults
<b>Flashing</b>	There Is A System Fault Waiting To Be Acknowledged

*Table 10: FAULT Indicator Functions*

## **Audible Indicators**

In general, the audible indications given out by the codepad are as follows:

<b>Indicator</b>	<b>Definition</b>
<b>One Short Beep</b>	A Button Has Been Pressed On The Codepad Or End Of Exit Time In STAY Mode 1 or STAY Mode 2
<b>Two Short Beeps</b>	The System Has Accepted Your Code
<b>Three Short Beeps</b>	The Requested Function Has Been Executed
<b>One Long Beep</b>	Indicates The End Of Exit Time In AWAY Mode Or The Requested Operation Has Been Denied Or Aborted
<b>One Short Beep Every Second</b>	Walk Test Mode Is Currently Active Or Warning Before Automatic Arming Takes Place
<b>One Short Beep Every Minute</b>	There Is A System Fault Waiting To Be Acknowledged

*Table 11: Audible Indications*

## LCD Codepad Indicators

The LCD fixed icon codepads provide full zone status indication at all times as well as a number of special icons which indicate such things as system armed, system disarmed, mains fail, system fault and other system functions.

The following table outlines all of the indicators that will be found on the “CP5 Eight Zone LCD Codepad (CP508L)” and the “CP5 Sixteen Zone LCD Codepad (CP516L)”.









<p><b>Zone Indicators</b></p> <p>1 2 3 ....</p>	<p>The ZONE indicators (1-8 on CP508L and 1-16 on CP516L) show the status of each zone.  <b>Illuminated</b> = Zone Unsealed <b>Flashing</b> = Zone In Alarm <b>Off</b> = Zone Sealed</p>
<p><b>Mains Indicator</b></p> 	<p>The MAINS icon indicates the status of the AC mains power supply.  <b>Illuminated</b> = AC Mains OK <b>Flashing</b> = AC Mains Disconnected Or Fail</p>
<p><b>Armed In AWAY Mode</b></p> 	<p>The AWAY icon illuminates when the system is armed in the AWAY mode. The <b>ON</b> indicator will also illuminate when the system is armed in the AWAY mode.</p>
<p><b>Armed In STAY Mode</b></p> 	<p>The STAY icon illuminates when the system is armed in the STAY mode. The <b>ON</b> and <b>OFF</b> indicators will also illuminate when the system is armed in the STAY mode.</p>
<p><b>System Disarmed</b></p> 	<p>This icon will illuminate when the system has been disarmed. The <b>OFF</b> indicator will also illuminate when the system has been disarmed.</p>
<p><b>Zone Isolating Mode</b></p> 	<p>This indicator will illuminate when you attempt to isolate zones. The person will flash once every 3 seconds.</p>
<p><b>Fault Indicator</b></p> 	<p>The FAULT icon will illuminate if the control panel has registered a fault condition.  <b>Steady</b> = A fault has been acknowledged. <b>Flashing</b> = A new fault has occurred.  <b>Off</b> = No faults have occurred.</p>
<p><b>Programming Mode</b></p>  <p>Flashing</p>	<p>This indicator will illuminate when the system has entered either Installer’s Programming Mode or Operators Programming Mode. Both persons will flash.</p>
<p><b>Off Indicator / Zone Sealed</b></p> 	<p>The OFF icon will illuminate when the system is in the disarmed state and will flash when a zone becomes unsealed. It will stop flashing when all zones are sealed.</p>
<p><b>On Indicator / Zone In Alarm</b></p> 	<p>The ON icon will illuminate when the system is armed in the AWAY mode and will flash when an alarm occurs. The indicator will reset once a valid user code has been entered.</p>

Table 12: ICON Indicators and Descriptions

## System Operations

### Arming The System In AWAY Mode

There are two methods for arming your system in the AWAY Mode. Method one is standard and will always operate. Method two is optional and requires to be enabled in "LOCATION 670" on page 159.

---

**Note: Single button arming in AWAY Mode will report as user code number 32.**

---

#### Method One

##### How To Arm The System In AWAY Mode

1. Enter your **CODE** followed by the **AWAY** button.  
Two beeps will be heard and the AWAY indicator will illuminate. Exit time will now begin.

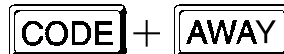

#### Method Two

##### How To Arm The System In AWAY Mode

1. Hold down the **AWAY** button until two beeps are heard.  
The AWAY indicator will illuminate and exit time will now begin. Refer to Option 2 in "LOCATION 670" on page 159 to enable "Enable Single Button Arming In AWAY Mode, STAY Mode 1 and STAY Mode 2".



If a zone is not sealed at the end of exit time the zone will be automatically isolated. It will become an active part of the system again as soon as it has resealed (ie. If a window is left open after exit time has expired, the window will not be an active part of the system until it has closed. Opening the window after exit time has expired will cause an alarm condition).

### Forced Arming

The feature of arming the system when a zone is not sealed is known as forced arming. To enable forced arming, Option 1 in "LOCATION 665" on page 152 will need to be enabled.

If the AWAY indicator does not illuminate and a long beep is heard, forced arming is not permitted. If this is the case you must ensure that all zones are sealed or manually isolated before you can arm the system.

### Disarming The System From AWAY Mode

##### How To Disarm The System From AWAY Mode

1. Enter your **CODE** followed by the **AWAY** button.  
Two beeps will be heard and the AWAY indicator will extinguish. A flashing ZONE indicator represents a previous alarm on that zone.

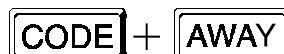

## Arming The System In STAY Mode 1

STAY Mode 1 is when the system has been armed with particular zones automatically isolated. These zones must be programmed by the installer.

When there is a need to arm only the system perimeter, this mode is extremely handy. It automatically disables the interior detection zones for allowing movement within the protected area while at the same time arming the perimeter zones.

There are two methods for arming your system in STAY Mode 1. Method one is standard and will always operate. Method two is optional and needs to be enabled in "LOCATION 670" on page 159.

**Note: Single button arming in STAY Mode 1 will report as user code number 32.**

### Method One

#### How To Arm The System In STAY Mode 1

1. Enter your **CODE** followed by the **STAY** button.  
Two beeps will be heard and the STAY indicator will illuminate. Exit time for STAY Mode 1 will now commence.

Any zones that have been programmed for STAY Mode 1 will be automatically isolated and their respective indicators will begin to flash until exit time expires. At the end of exit time, the ZONE indicators will extinguish and the codepad will give one short beep.

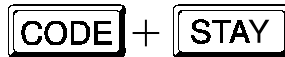

### Method Two

#### How To Arm The System In STAY Mode 1

1. Hold down the **STAY** button until two beeps are heard.  
The STAY indicator will illuminate and exit time for STAY Mode 1 will now commence.

Any zone that have been programmed for STAY Mode 1 will be automatically isolated and their respective indicators will begin to flash until exit time expires. At the end of exit time, the zone indicators will extinguish and the codepad will give one short beep.



If a zone is not sealed at the end of exit time the zone will be automatically isolated. It will become an active part of the system again as soon as it has resealed (ie. If a window is left open after exit time has expired, the window will not be an active part of the system until it has closed. Opening the window after exit time has expired will cause an alarm condition).

### Forced Arming

The feature of arming the system when a zone is not sealed is known as forced arming. To enable forced arming, Option 1 in "LOCATION 665" on page 152 will need to be enabled.

If the STAY indicator does not illuminate and a long beep is heard, forced arming is not permitted. If this is the case, you must ensure that all zones are sealed or manually isolated before you can arm the system.

## Disarming The System From STAY Mode 1

There are two methods for disarming the system from STAY Mode 1. Method one is standard and will always operate. Method two is optional and requires to be enabled in "LOCATION 670" on page 159.

---

**Note:** Method two will not operate unless "Enable Single Button Arming In AWAY Mode, STAY Mode 1 and STAY Mode 2" has been enabled.

---

### Method One

#### How To Disarm The System From STAY Mode 1

1. Enter your **CODE** followed by the **STAY** button.  
Two beeps will be heard and the STAY indicator will extinguish. A flashing ZONE indicator represents a previous alarm on that zone.

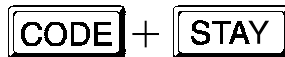

OR



### Method Two

A flashing ZONE indicator represents a previous alarm on that zone. If this is the case a valid user code will need to be used to disarm the system. To enable method two, Option 4 in "LOCATION 670" on page 159 will need to be enabled.

---

**Note:** Single button disarming from STAY Mode 1 will report as user code number 32.

---

#### How To Disarm The System From STAY Mode 1

1. Hold down the **STAY** button until two beeps are heard.  
The STAY indicator will extinguish and the system will be disarmed.



## Arming The System In STAY Mode 2

STAY Mode 2 is when the system has been armed with particular zones automatically isolated. These zones are programmed via the Master Code holder.

When there is a need to arm the system perimeter only, this mode is extremely handy. It automatically disables the interior detection zones allowing for movement within the protected area while at the same time arming the perimeter zones.

For STAY Mode 2 to operate, Option 2 in "LOCATION 670" on page 159 will need to be enabled. Refer to the Master Code Function - "Setting STAY Mode 2 Zones" on page 59 for further information on programming zones for STAY Mode 2.

---

**Note: Single button arming in STAY Mode 2 will report as user code number 32.**

---

### How To Arm The System In STAY Mode 2

1. Hold down the  button until two beeps are heard.  
The STAY indicator will illuminate and exit time for STAY Mode 2 will now commence.

Any zone that has been programmed for STAY Mode 2 will be automatically isolated and their respective indicators will begin to flash until exit time expires. At the end of exit time, the ZONE indicators will extinguish and the codepad will give one short beep.



If a zone is not sealed at the end of exit time the zone will be automatically isolated. It will become an active part of the system again as soon as it has resealed (ie. If a window is left open after exit time has expired, the window will not be an active part of the system until it has closed. Opening the window after exit time has expired will cause an alarm condition).

### Forced Arming

The feature of arming the system when a zone is not sealed is known as forced arming. To enable forced arming, Option 1 in "LOCATION 665" on page 152 will need to be enabled.

If the STAY indicator does not illuminate and a long beep is heard, forced arming is not permitted. If this is the case, you must ensure that all zones are sealed or manually isolated before you can arm the system.

## Disarming The System From STAY Mode 2

There are two methods for disarming the system from STAY Mode 2. Method one is standard and will always operate. Method two is optional and requires to be enabled in "LOCATION 670" on page 159.

---

**Note:** Method two will not operate unless "Enable Single Button Arming In AWAY Mode, STAY Mode 1 and STAY Mode 2" has also been enabled.

---

### Method One

#### How To Disarm The System From STAY Mode 2

1. Enter your **CODE** followed by the **STAY** button.  
Two beeps will be heard and the STAY indicator will extinguish. A flashing ZONE indicator represents a previous alarm on that zone.

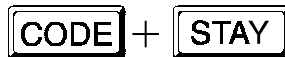

OR



### Method Two

A flashing ZONE indicator represents a previous alarm on that zone. If this is the case, a valid user code will need to be used to disarm the system. To enable method two, Option 4 in "LOCATION 670" on page 159 will need to be enabled.

#### How To Disarm The System From STAY Mode 2

1. Hold down button **0** until two beeps are heard.  
The STAY indicator will extinguish and the system will be disarmed.



## Codepad Duress Alarm

A codepad duress alarm can be used as a hold up alarm. This will occur when the number **9** is added to the end of any valid user code that is being used to disarm the system. A duress alarm is always silent and can only be made use of if your system is reporting back to a monitoring station or pocket pager.



## Codepad Panic Alarm - Software Version 1.10 - 1.36

A codepad panic alarm will be triggered when any two outside buttons in the same horizontal row on the remote codepad are pressed simultaneously. This is an audible alarm. Refer to Option 4 in "LOCATION 666" on page 153 to enable codepad panic to be silent.

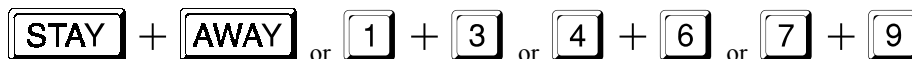

## Codepad Panic Alarm - Software Version 1.37 Onwards

A codepad panic alarm will be triggered when either the **1** and **3** buttons or the **STAY** and **AWAY** buttons are pressed simultaneously. This is an audible alarm. Refer to Option 4 in "LOCATION 666" on page 153 to enable codepad panic to be silent.



## Codepad Fire Alarm - Software Version 1.37 Onwards

A codepad fire alarm will be triggered when the **4** and **6** buttons on the remote codepad are pressed simultaneously. This is an audible alarm. A distinct fire sound is emitted through the horn speaker to indicate this type of alarm condition. The fire sound is different to the burglary sound.

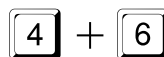

## Codepad Medical Alarm - Software Version 1.37

A codepad medical alarm will be triggered when the **7** and **9** buttons on the codepad are pressed simultaneously. This is an audible alarm.

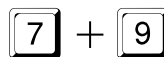

---

**Note:** To disable both the reporting and the audible alarms for codepad panic, codepad fire and codepad medical alarms, the following will need to be programmed.

In "LOCATION 666" on page 153, "Option 2 - Enable Codepad Panic To Be Silent" will need to be enabled. You will also need to program "LOCATION 483" on page 117 as 0.

---



## Isolating Zones

When a zone is isolated, access is allowed into that zone at all times. Isolating zones is performed by one of two methods. One way requires the use of a valid user code while the other way does not. The ability to isolate zones is governed by the priority level allocated to each user code holder. Some user code holders may not be able to isolate zones. Refer to "User Code Priority" on page 99 for further details.

Twenty four hour zone types and zones not used cannot be isolated. If isolation of these zones is attempted, a long beep will be heard.

### Standard Isolating

1. Press the **STAY** button twice.  
Three beeps will be heard.
2. \* Enter the **ZONE NUMBER** required to be isolated.
3. Press the **STAY** button.
4. \* Enter the next **ZONE NUMBER** required to be isolated.
5. Press the **STAY** button.
6. Press the **AWAY** button when finished selecting the zones to be isolated.  
Two beeps will be heard.

The isolated zones will now continue to flash until the system has next been disarmed. The system is ready to be armed in AWAY Mode or STAY Mode 1.

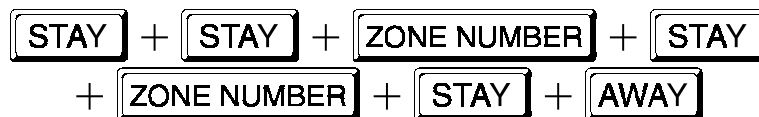

### Code To Isolate

1. Press the **STAY** button.
2. Enter your **CODE**.
3. Press the **STAY** button.  
Three beeps will be heard.
4. \* Enter the **ZONE NUMBER** required to be isolated.
5. Press the **STAY** button.
6. \* Enter the next **ZONE NUMBER** required to be isolated.
7. Press the **STAY** button.
8. Press the **AWAY** button when finished selecting the zones to be isolated.  
Two beeps will be heard.

The isolated zones will now continue to flash until the system has next been disarmed. The system is ready to be armed in AWAY Mode or STAY Mode 1.

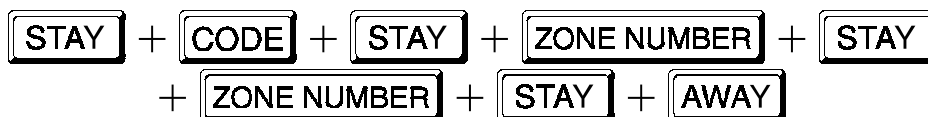

\* As each zone is isolated, the corresponding **ZONE** indicator will begin to flash. If a mistake is made, press the zone number that was incorrectly entered followed by the **STAY** button. This zone is now no longer isolated and the **ZONE** indicator will extinguish.

## Fault Analysis Mode

Whenever a system fault occurs, the FAULT or MAINS indicator will flash and the codepad will beep once every minute.

If the MAINS indicator is flashing, this is because the AC mains has been disconnected. There is no need to determine this type of system fault. Pressing the **AWAY** button for two seconds will acknowledge the AC mains fault and will stop the codepad beeping once every minute.

### How To Determine The Type Of System Fault

To determine the type of system fault that has occurred, enter "Fault Analysis Mode" by following the procedures below.

1. Hold down the **5** button until two beeps are heard.  
The FAULT indicator should remain steady and the STAY and AWAY indicators should flash in unison with each other.

The type of system fault will be indicated by the ZONE indicators. Refer to the "Table 13: Fault Indicators" for the list of different system faults that may occur.

Zone Indicator	Fault Description
1	Low Battery
2	Date and Time
3	Sensor Watch
4	Horn Speaker Disconnected
5	Telephone Line Fault
6	E <sup>2</sup> Fault
7	Zone 16 In Alarm - Partitioned Systems Only
8	Communications Failure

Table 13: Fault Indicators

2. To exit fault analysis mode, press the **AWAY** button. The STAY and AWAY indicators will extinguish and the FAULT indicator will remain illuminated.

### How To Acknowledge The System Fault

1. To acknowledge the system fault, press the **AWAY** button. The FAULT indicator will remain illuminated and the codepad will cease its once a minute beep.

## Fault Descriptions

### 1 Low Battery

A low battery fault will register when the battery supply voltage falls below 10.5 volts or when a dynamic battery test detects a low capacity battery. This fault will clear after a successful dynamic battery test. A dynamic battery test is performed every four hours once power has been connected to the control panel and also every time the system is armed in AWAY Mode, STAY Mode 1 and STAY Mode 2.

### 2 Date and Time

The date and time fault will register every time the control panel has been powered down. This fault will clear after the date and time has been programmed. Refer to "Setting The Date and Time" on page 58 for further information on setting the date and time.

### 3 Sensor Watch

A sensor watch fault will register because one of the detection devices has stopped working or has failed to detect movement for the programmed time period whilst the control panel is disarmed. The fault will clear after the registered zone has been unsealed and resealed again.

To find out which zone has registered the sensor watch fault, enter "Fault Analysis Mode" and hold down the **5** button to display the zone that has registered the sensor watch fault. Refer to "LOCATION 642 - 643" on page 142 for setting sensor watch time and "Zone Options" on page 107 for setting zones for sensor watch.

#### **4 Horn Speaker Monitor**

A horn speaker fault will register when the horn speaker becomes disconnected from the control panel. This fault will clear when the horn speaker is reconnected. Refer to "LOCATION 665" on page 152 to enable monitoring of the horn speaker.

#### **5 Telephone Line Fault**

A telephone line fault will register if the telephone line has been disconnected from the control panel for more than 40 seconds. This can only occur if the Telephone Line Fault Module (CC887) has been connected to the "Line Fault Module" socket on the printed circuit board and Option 1 in "LOCATION 673" on page 164 has been enabled. The fault will clear once the telephone line has been reconnected for more than 40 seconds.

#### **6 E2 Fault**

An E2 fault will register when the control panel detects an internal checksum error. The control panel will need to be powered down and defaulted to clear this fault.

#### **7 Zone 16 In Alarm - Partitioned Systems Only**

When the control panel has been partitioned, Zone 16 cannot be allocated to an area. When Zone 16 has triggered, the zone will register as a system fault on any "CP5 Area Addressable (CP500A)" codepad. If a "CP5 Master Partitioned (CP500P)" codepad has been used, the AUX indicator will illuminate.

#### **8 Communication Failure**

A communication failure fault will register if the control panel was unsuccessful in calling the receiving party after the control panel has exhausted its maximum number of attempts.

To find out which receiver has failed Press  again and zone 1 or 2 indicators will light up indicating zone 1 for Telco reporting zone 2 for Safecom.

---

**Note:** If the control panel is not connected to the telephone line and no Primary Telephone Number or Secondary Telephone Numbers have been programmed, the control panel will still register this fault if Option 1 in "LOCATION 663" is enabled and a communication dialler hybrid is fitted.

---

#### **AC Mains Failure**

An AC mains failure will flash the MAINS indicator, sound the codepad buzzer once every minute and an "AC Fail" report will be transmitted to the monitoring station. This fault will clear after the AC mains has been reconnected. An "AC Restore" report will be transmitted once the AC mains has been restored for more than two minutes.

If you require the MAINS indicator to flash and an "AC Fail" report to be transmitted after one hour, enable Option 4 in "LOCATION 667" on page 154. If you wish only to transmit an "AC Fail" report and ignore the mains failure on the codepad (**New - Software Version 1.30 Onwards**), enable Option 4 in "LOCATION 668" on page 156.



# System Functions

---

## **This Section Includes The Following:**

- *Installer Code Functions*
- *Master Code Functions*
- *User Code Function*
- *Hold Down Functions*

## System Functions

This section deals with the more advanced features that are required for testing and regular maintenance of the system. Features such as Installer Code Functions, Master Code Functions and Hold Down Functions are covered in this section.

### Installer Code Functions

Installer Code Functions are designed to allow the installer to perform various system tests without the need to know a Master Code.

To enter the required installer code function, enter the **INSTALLER CODE** followed by the required **FUNCTION** digit and the **AWAY** button.



These functions can only be carried out when the system is in the disarmed state.

Function	Description
2	Set The Number Of Days Until The First Test Report
3	Event Memory Recall Mode
4	Walk Test Mode
5	Satellite Siren Service Mode - (EDMSAT)
7	Turning Telephone Monitor Mode On and Off

Table 14: Installer Code Functions

### 2 Set The Number Of Days Until The First Test Report

If test reports are required "LOCATION 506 - 513" on page 122 will need to be programmed. After this has been carried out, test reports need to be initiated by setting the first test report. If the first test report is not set, the test report will be transmitted in the number of days as programmed in the repeat interval programmed in "LOCATION 506 - 513".

---

**Note:** Each time Installer's Programming Mode has been entered, you will need to reset the number of days until the first test report. Otherwise, the next test report will report as programmed in the repeat interval time.

---

#### How To Set The First Test Report

1. Enter the **INSTALLER CODE** followed by **2** and the **AWAY** button.  
Three beeps will be heard and the STAY and AWAY indicators will begin to flash.
2. Enter the **No. OF DAYS** to wait (1-99) until the first test report.
3. Press the **AWAY** button when finished.  
Two beeps will be heard and the STAY and AWAY indicators will extinguish.



---

**Note:** Test reports will not be transmitted if the Subscriber ID Number is 0000. The number of days decrements by one at 2400 hours as set in "LOCATION 901 - 904" on page 148.

---

### 3 Event Memory Recall Mode

This feature allows you to playback the last forty events that have occurred to the system. The event memory recall mode reports all alarms and arming/disarming of the system in the AWAY Mode, STAY Mode 1 and STAY Mode 2. This function helps with trouble shooting system faults. The events are displayed via the codepad indicators.

#### How To Enter The Event Memory Recall Mode

1. Enter your **INSTALLER CODE** followed by **3** and the **AWAY** button.  
Three beeps will be heard. The events will be played back via the ZONE indicators on the codepad in reverse chronological order.



If the system has been partitioned, only the last ten events will be recorded for each of the four areas. You will be required to enter this mode at each of the four area codepads.

#### Example

If the events were as follows:

Event No	Description Of Event
1	System Armed In AWAY Mode
2	Alarm In Zone 3
3	Alarm In Zone 4
4	System Disarmed

Table 15: Event Memory Recall - Example Events

The event memory playback will report as follows:

Event No	Codepad Indicator	Event Description
4	All Indicators Off Except MAINS	System Disarmed
3	Zone 4 + AWAY Indicator Illuminates	Alarm In Zone 4
2	Zone 3 + AWAY Indicator Illuminates	Alarm In Zone 3
1	AWAY Indicator Illuminates	System Armed In AWAY Mode

Table 16: Event Memory Recall - Example Event Playback

Each event is indicated by a beep and an illuminated indicator. Resetting a 24 hour alarm in the disarmed state is indicated by one beep only. After the last event, three beeps will be heard to indicate the end of playback. The replay can be terminated at any time by pressing the **AWAY** button.

---

**Note:** If the control panel has been powered down, the memory of all events will be lost.

---

## 4 Walk Test Mode

Walk test mode allows you to test detection devices to ensure that they are functioning correctly. Before activating walk test mode, isolate any zones that are not required for testing. Refer to "Isolating Zones" on page 41 for further information.

### How To Enter Walk Test Mode

1. Enter the **INSTALLER CODE** followed by **4** and the **AWAY** button.  
Three beeps will be heard and the STAY and AWAY indicators will begin to flash. The codepad will beep once every second while the system is in the walk test mode.
2. Unseal and seal the zones to be tested.  
The codepad will sound a long beep while the horn speaker will sound a short beep every time a zone is sealed or unsealed.
3. Press the **AWAY** button to exit this mode.  
Two beeps will be heard and the STAY and AWAY indicators will extinguish.



## 5 Satellite Siren Service Mode

If an EDMSAT is connected to Output 1, this mode will allow you to perform service work on the satellite siren without triggering the siren or the strobe. The unit will return to its normal working state the next time the system is armed.

### How To Enter Satellite Siren Service Mode

1. Enter your **INSTALLER CODE** followed by **5** and the **AWAY** button.  
Three beeps will be heard.





## 7 Telephone Monitor Mode On and Off

Telephone monitor mode allows the remote codepad to be used for a visual representation of data transmissions between the control panel and the base station receiver. The dialling sequence is also shown in this mode.

The codepad will beep once every two seconds while telephone monitor mode is turned on regardless of whether the system is in Installer's Programming Mode or normal operating mode. The first five indicators are used to display the progressive steps for a transmission to the base station receiver.

Zone LED	Dialling Event
1	Telephone Line Seized
2	Dialling Phone Number
3	Handshake Received
4	Data Is Being Transmitted
5	Kiss-Off Received
None	Telephone Line Released

Table 17: Telephone Monitor Mode Indications

### How To Turn Telephone Monitor Mode On

1. Enter your **INSTALLER CODE** followed by **7** and the **AWAY** button.  
Three beeps will be heard.

**INSTALLER CODE** + **7** + **AWAY**

### How To Turn Telephone Monitor Mode Off

1. Enter your **INSTALLER CODE** followed by **7** and the **AWAY** button.  
Two beeps will be heard.

**INSTALLER CODE** + **7** + **AWAY**

---

**note:** To test the on-board dialler, you will need to program Option 1 – Disable Safecom Communication Reporting in LOCATION 896 before you power down the system and re-apply the power for the on-board dialler to operate or have the base station perform a reframe of the Safecom System.

After you have successfully tested the reporting of the on-board dialler, you will need to disable Option 1 in LOCATION 896 and then power down the system or have the base station perform a reframe of the Safecom System.

---

## Master Code Functions

Master Code Functions are designed to allow those users that have the appropriate priority level to perform certain functions of a Supervisory level. **These functions can only be carried out when the system is in the disarmed state.**

**Note:** The default Master Code is **2580** and is known as User Code 1. It is possible for the system to have multiple Master Codes. Refer to "User Code Priority" on page 99 for more information.



Function	Description
0	Arming and Disarming All Areas At The Same Time - Partitioned Systems Only
1	Changing and Deleting User Codes
2	Changing Domestic Phone Numbers
3	Event Memory Recall Mode
4	Walk Test Mode
5	Turning Outputs On and Off
6	Setting The Date and Time
7	Turning Day Alarm On and Off (Software Version 1.10 Only)
8	Setting Zones For STAY Mode 2

Table 18: Master Code Functions

### 0 Arming and Disarming All Areas At The Same Time - Partitioned Systems Only

This option allows the user to arm and disarm all areas at the same time that the code belongs to.

All areas that the code belongs to will arm or disarm to follow the state of the area that the code was entered from (ie. If you disarm an area, all other areas will disarm or if you arm an area, all other areas will arm as well).

This allows the user to ensure that all areas will be armed by pressing one extra button rather than entering a user code at each area codepad. For this feature to function, enable Option 1 in "LOCATION 670" on page 159.

This process can be carried out from either the "CP5 Area Addressable (CP500A)" codepads or the "CP5 Master Partitioned (CP500P)" codepads.

#### How To Arm Or Disarm All Areas That The Code Belongs To At The Same Time

1. Enter your **MASTER CODE** followed by **0** and the **AWAY** button.  
Two beeps will be heard.



## 1 Changing and Deleting User Codes

This function allows a Master Code holder to add/change or delete any of the system user codes including Auxiliary Codes 1 and 2. The auxiliary codes are treated as user codes 33 and 34.

### How To Add Or Change A User Code

1. Enter your **MASTER CODE** followed by **1** and the **AWAY** button.  
Three beeps will be heard and the STAY and AWAY indicators will begin to flash.
2. Enter the **USER NUMBER** (1-34) that you wish to alter followed by the **AWAY** button.  
Two beeps will be heard and the corresponding ZONE indicator will illuminate. Refer to "Table 19: Zone Indicators Showing Relative User Numbers" on page 53 .
3. Enter the digits required for the **NEW CODE** followed by the **AWAY** button.  
Two beeps will be heard and the STAY and AWAY indicators will extinguish.

If you wish to change any further user codes, repeat this procedure as many times as required.

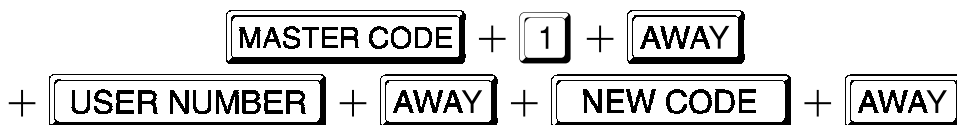

---

**Note:** When adding or changing user codes, this function will automatically terminate if a button is not pressed within sixty seconds. Pressing the **AWAY** button will also terminate the session at anytime. One long beep indicates the code entered already exists, an incorrect user number was selected, or the area allocation of the user code is incorrect if the system has been partitioned.

---

### How To Delete A User Code (Software Version 1.10 Only)

1. Enter your **MASTER CODE** followed by **1** and the **AWAY** button.  
Three beeps will be heard and the STAY and AWAY indicators will begin to flash.
2. Enter the **USER NUMBER** (1-34) that you wish to delete followed by the **AWAY** button.  
Two beeps will be heard and the corresponding ZONE indicator will illuminate. Refer to "Table 19: Zone Indicators Showing Relative User Numbers" on page 53.
3. Press the **AWAY** button to delete the user code.  
Two beeps will be heard and the STAY and AWAY indicators will extinguish.

If you wish to erase any further user codes, repeat this procedure as many times as required.

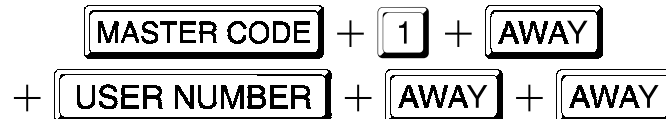

### How To Delete A User Code (Software Version 1.20 Onwards)

1. Enter your **MASTER CODE** followed by **1** and the **AWAY** button.  
Three beeps will be heard and the STAY and AWAY indicators will begin to flash.
2. Enter the **USER NUMBER** (1-34) that you wish to delete followed by the **AWAY** button.  
Two beeps will be heard and the corresponding ZONE indicator will illuminate. Refer to "Table 19: Zone Indicators Showing Relative User Numbers" on page 53.
3. Press the **STAY** button to delete the user code.  
Two beeps will be heard and the STAY and AWAY indicators will extinguish.

If you wish to erase any further user codes, repeat this procedure as many times as required.

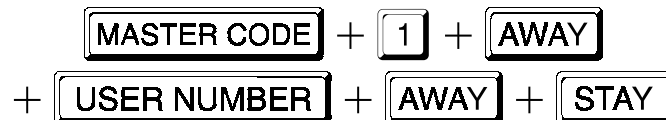

---

**Note:** When deleting user codes, this function will automatically terminate if a button is not pressed within sixty seconds. Pressing the **AWAY** button will also terminate the session at anytime. One long beep indicates the code entered already exists, an incorrect user number was selected, or the area allocation of the user code is incorrect if the system has been partitioned.

---

### Auxiliary Codes

Auxiliary Codes 1 and 2 are treated as user codes 33 and 34. To add or change either of these two codes, refer to "How To Add Or Change A User Code" on page 51. To delete either of these two codes, refer to "How To Delete A User Code" on page 52.

**Zone Indicators Showing Relative User Numbers**

User No	Zone 1 Indicator	Zone 2 Indicator	Zone 3 Indicator	Zone 4 Indicator	Zone 5 Indicator	Zone 6 Indicator	Zone 7 Indicator	Zone 8 Indicator	MAINS Indicator	FAULT Indicator
1	✓									
2		✓								
3			✓							
4				✓						
5					✓					
6						✓				
7							✓			
8								✓		
9	✓							✓		
10									✓	
11	✓								✓	
12		✓							✓	
13			✓						✓	
14				✓					✓	
15					✓				✓	
16						✓			✓	
17							✓		✓	
18								✓	✓	
19	✓							✓	✓	
20										✓
21	✓									✓
22		✓								✓
23			✓							✓
24				✓						✓
25					✓					✓
26						✓				✓
27							✓			✓
28								✓		✓
29	✓							✓		✓
30									✓	✓
31	✓								✓	✓
32		✓							✓	✓
33			✓						✓	✓
34				✓					✓	✓

Table 19: Zone Indicators Showing Relative User Numbers

## 2 Programming Domestic Phone Numbers

This option allows a Master Code holder to view and program the required telephone numbers that the system will call in the event of an alarm. For a more detailed description, refer to "Domestic Reporting" on page 78 for further information.

### How To Change Domestic Phone Numbers

1. Enter your **MASTER CODE** followed by **2** and the **AWAY** button.  
Three beeps will be heard and the STAY and AWAY indicators will begin to flash.

If there are telephone numbers programmed, they will be displayed one digit at a time via the zone indicators on the codepad. Refer to "Table 20: Indicators For Changing Phone Numbers" on page 54 for the indicators and their meanings.

If there are no telephone numbers programmed, a further two beeps will be heard after entering this mode. These two beeps are normally heard after the last digit of the last phone number has been displayed.

2. Enter the required phone number (Each number will be displayed as it entered).
3. After each phone number, press the **STAY** button before entering the next phone number. This separates the end of the first phone number and the beginning of the next.
4. After the last phone number has been entered, press the **AWAY** button.  
Two beeps will be heard and the STAY and AWAY indicators will extinguish.

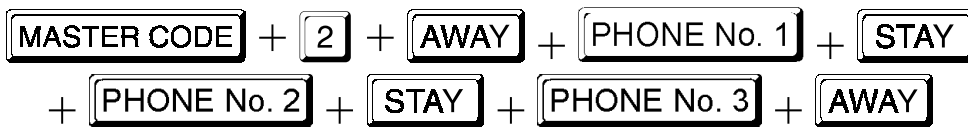

### How To Disable Domestic Dialling

If at any time the user wishes to cancel domestic dialling for any reason (eg. They are moving house and they do not wish the system to continue calling their work place or mobile phone etc), they may enter the **MASTER CODE** followed by **2**, the **AWAY** button, the **STAY** button and the **AWAY** button to disable domestic dialling.



**Indicators For Changing Phone Numbers**

Digit	Zone 1 Indicator	Zone 2 Indicator	Zone 3 Indicator	Zone 4 Indicator	Zone 5 Indicator	Zone 6 Indicator	Zone 7 Indicator	Zone 8 Indicator	MAINS Indicator
0									✓
1	✓								
2		✓							
3			✓						
4				✓					
5					✓				
6						✓			
7							✓		
8								✓	
9	✓							✓	
Number Separator				✓					✓

Table 20: Indicators For Changing Phone Numbers

### 3 Event Memory Recall Mode

This feature allows you to playback the last forty events that have occurred to the system. The event memory recall mode reports all alarms and arming/disarming of the system in the STAY or AWAY Modes. This function helps with trouble shooting system faults. The events are displayed via the codepad indicators.

#### How To Enter The Event Memory Recall Mode

1. Enter your **MASTER CODE** followed by **3** and the **AWAY** button.  
Three beeps will be heard.

The events will be played back via the ZONE indicators on the codepad in reverse chronological order.



If the system has been partitioned, only the last ten events will be recorded for each of the four areas. You will be required to enter this mode at each of the four areas.

#### Example

If the events were as follows:

Event No	Description Of Event
1	System Armed In AWAY Mode
2	Alarm In Zone 3
3	Alarm In Zone 4
4	System Disarmed

Table 21: Event Memory Recall - Example Events

The event memory playback will report as follows:

Event No	Codepad Indicator	Event Description
4	All Indicators Off Except MAINS	System Disarmed
3	Zone 4 + AWAY Indicator Illuminates	Alarm In Zone 4
2	Zone 3 + AWAY Indicator Illuminates	Alarm In Zone 3
1	AWAY Indicator Illuminates	System Armed In AWAY Mode

Table 22: Event Memory Recall - Example Event Playback

Each event is indicated by a beep and an illuminated indicator. Resetting a 24 hour alarm in the disarmed state is indicated by one beep only. After the last event, three beeps will be heard to indicate the end of playback. The replay can be terminated at any time by pressing the **AWAY** button.

---

**Note:** If the control panel has been powered down, the memory of all events will be lost.

---

## 4 Walk Test Mode

Walk test mode allows you to test detection devices to ensure that they are functioning correctly. This should be performed on a weekly basis.

Before activating walk test mode, isolate any zones that are not required for testing. Refer to "Isolating Zones" on page 41 for more information on isolating zones.

### How To Enter Walk Test Mode

1. Enter your **MASTER CODE** followed by **4** and the **AWAY** button.  
Three beeps will be heard and the STAY and AWAY indicators will begin to flash. The codepad will beep once every second while the system is in the walk test mode.
2. Unseal and seal the zones to be tested. The codepad will sound a long beep and the horn speaker will sound a short beep every time a zone is sealed or unsealed.
3. Press the **AWAY** button to exit this mode.  
Two beeps will be heard and the STAY and AWAY indicators will extinguish.

**MASTER CODE** + **4** + **AWAY**



## 5 Turning Outputs On and Off

If an output has been programmed for remote operation via the telephone or to automatically turn on at a particular time, it can be turned on and off using this Master Code Function via the remote codepad, over the telephone via the DTMF Command Module or the Alarm Link Software.

### How To Turn An Output ON From The Remote Codepad

1. Enter your **MASTER CODE** followed by **5** and the **AWAY** button.  
Three beeps will be heard and the STAY and AWAY indicators will begin to flash.
2. Enter the required **OUTPUT No.** followed by the **AWAY** button.  
Three beeps will be heard and the output will now turn on. Repeat step 2 if more than one output is required to be turned on.
3. Press the **AWAY** button again to exit this mode.  
Two beeps will be heard and the STAY and AWAY indicators will extinguish.

**MASTER CODE** + **5** + **AWAY** + **OUTPUT No.** + **AWAY** + **AWAY**

Output Number 1 = Output Event Type "2,8" (Refer to page 131)  
 Output Number 2 = Output Event Type "2,9" (Refer to page 131)  
 Output Number 3 = Output Event Type "2,10" (Refer to page 131)  
 Output Number 4 = Output Event Type "2,11" (Refer to page 131)  
 Output Number 5 = Output Event Type "1,1" (Refer to page 128)

### How To Turn An Output OFF From The Remote Codepad

1. Enter your **MASTER CODE** followed by **5** and the **AWAY** button.  
Three beeps will be heard and the STAY and AWAY indicators will begin to flash.
2. Enter the required **OUTPUT No.** followed by the **STAY** button.  
Two beeps will be heard and the output will turn off. Repeat step 2 if more than one output is required to be turned off.
3. Press the **AWAY** button to exit this mode.  
Two beeps will be heard and the STAY and AWAY indicators will extinguish.

**MASTER CODE** + **5** + **AWAY** + **OUTPUT No.** + **STAY** + **AWAY**

Output Number 1 = Output Event Type "2,8" (Refer to page 131)  
 Output Number 2 = Output Event Type "2,9" (Refer to page 131)  
 Output Number 3 = Output Event Type "2,10" (Refer to page 131)  
 Output Number 4 = Output Event Type "2,11" (Refer to page 131)  
 Output Number 5 = Output Event Type "1,1" (Refer to page 128)

## 6 Setting The Date and Time

This function needs to be used when the date and time requires to be changed or the system has been powered down.

### How To Set The New Date and Time

1. Enter your **MASTER CODE** followed by **6** and the **AWAY** button.  
Three beeps will be heard and the STAY and AWAY indicators will begin to flash.
2. Enter the day, month, year, hour and minute using the (DD, MM, YY, HH, MM) format.
3. Press the **AWAY** button when finished.  
Two beeps will be heard and the STAY and AWAY indicators will extinguish.

**MASTER CODE** + **6** + **AWAY**

### Example

If the date and time needs to be set for the 1st January 1996 at 10:00 PM, program the date and time as follows;

**MASTER CODE** + **6** + **AWAY**  
 + **0** + **1** + **0** + **1** + **9** + **6** + **2** + **2** + **0** + **0** + **AWAY**

## 7 Turning Day Alarm On and Off (Software Version 1.10 Only)

Day alarm enables a combination of zones to be monitored while the system is in the disarmed state. Indications are available via any of the programmable outputs including the codepad buzzer.

### How To Turn Day Alarm ON

1. Enter your **MASTER CODE** followed by **7** and the **AWAY** button.  
Three beeps will be heard.

### How To Turn Day Alarm OFF

1. Enter your **MASTER CODE** followed by **7** and the **AWAY** button.  
Two beeps will be heard.

**MASTER CODE** + **7** + **AWAY**

## 8 Setting STAY Mode 2 Zones

This function allows the Master Code holder to select which zones are to be automatically isolated when the system is armed in STAY Mode 2. Every time the system is armed in STAY Mode 2, the zones programmed using this function will be automatically isolated until the system has been powered down or the Master Code holder changes the zones numbers required to be automatically isolated in STAY Mode 2.

This function will not operate when the system has been partitioned.

### How To Set STAY Mode 2 Zones

1. Enter your **MASTER CODE** followed by **8** and the **AWAY** button.  
Three beeps will be heard and the STAY indicator will begin to flash.
2. Enter the **ZONE NUMBER** that you wish to automatically isolate followed by the **STAY** button. The ZONE indicator will now begin to flash.
3. If more than one zone is required to be automatically isolated, repeat step 2 until all zones required have been set.
4. Press the **AWAY** button to exit this function.  
Two beeps will be heard and the STAY indicator will extinguish.

**MASTER CODE** + **8** + **AWAY**  
+ **ZONE NUMBER** + **STAY** + **ZONE NUMBER** + **STAY** + **AWAY**

## User Code Functions - Partitioned Systems Only



Function	Description
0	Arming and Disarming All Areas At The Same Time - Partitioned Systems Only

Table 23: User Code Functions

### 0 Arming and Disarming All Areas At The Same Time - Partitioned Systems Only

This option allows the user to arm and disarm all areas that the code belong to at the same time.

All areas that the code belongs to will arm or disarm to follow the state of the area that the code was entered from (ie. If you disarm an area, all other areas will disarm or if you arm an area, all other areas will arm as well).

This allows the user to ensure that all areas will be armed by pressing one extra button rather than entering a user code at each area codepad. For this feature to function, enable Option 1 in "LOCATION 670" on page 159.

This process can be carried out from either the "CP5 Area Addressable (CP500A)" codepads or the "CP5 Master Partitioned (CP500P)" codepads.

#### How To Arm Or Disarm All Areas That The Code Belongs To At The Same Time

1. Enter your **USER CODE** followed by **0** and the **AWAY** button.  
Two beeps will be heard.

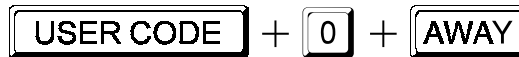

## Hold Down Functions

Hold down function have been incorporated to allow easy activation of specific operations. When a button is held down for two seconds, two beeps will be heard and a particular function will operate. The functions available are listed below.

### # **Arm The System In AWAY Mode**

Holding the **AWAY** button down until two beeps are heard will arm the system in the AWAY Mode. Refer to Option 2 in "LOCATION 670" on page 159 for setting this feature.

If the system has been partitioned, holding the **AWAY** button down until two beeps are heard on the "CP5 Area Addressable (CP500A)" codepad will only arm the area that the codepad is allocated to in AWAY Mode.

This hold down function does not operate on the "CP5 Master Partitioned (CP500P)" codepad as pressing the **AWAY** button will toggle you to the next area display.

### \* **Arm The System In STAY Mode 1**

Holding the **STAY** button down until two beeps are heard will arm the system in STAY Mode 1. Option 2 in "LOCATION 670" on page 159 will need to be enabled for this function to operate.

If there has not been an alarm during the armed cycle, holding the **STAY** button down a second time will disarm the system from STAY Mode 1. Option 4 in "LOCATION 670" on page 159 will need to be enabled for this hold down function to operate.

If an alarm has occurred or entry warning has been triggered, a valid user code will need to be used to disarm the system.

If the system has been partitioned, holding down the **STAY** button on the "CP5 Area Addressable (CP500A)" codepad will only arm the area that the codepad belongs to in STAY Mode 1. This function does not operate on the "CP5 Master Partitioned (CP500P)" codepad.

### 0 **Arm The System In STAY Mode 2**

Holding the **0** button down until two beeps are heard will arm the system in STAY Mode 2. Option 2 in "LOCATION 670" on page 159 will need to be enabled for this function to operate.

If there has not been an alarm during the armed cycle, holding the **0** button down again until two beeps are heard will disarm the system. Option 4 in "LOCATION 670" on page 159 will need to be enabled for this hold down function to operate.

If an alarm has occurred or entry warning has been triggered, a valid user code will need to be used to disarm the system.

STAY Mode 2 is not available when the system has been partitioned, therefore this hold down function does not operate when the system has been partitioned.

### 1 **Horn Speaker Test**

Holding the **1** button down until two beeps are heard will sound the horn speaker for a two second burst. No other sounding device will sound in this mode. If An EDMSAT (SS914) has been connected to the control panel, this function will test the horn speaker for a two second burst followed by the strobe connected to the satellite siren.

## **2 Bell Test**

Holding the **2** button down until two beeps are heard will sound the speakers for a two second burst. No other sounding device will sound in this mode.

If an EDMSAT (SS914) has been connected to the control panel, this function will test the horn speaker for a two second burst followed by the strobe connected to the satellite siren.

## **3 Strobe Test**

Holding the **3** button down will operate the strobe. No other device will operate in this mode.

If an EDMSAT (SS914) has been connected to the control panel, this function will also test the strobe on the satellite siren.

### **How To Turn Strobe Test ON**

1. Hold down the **3** button until three beeps are heard.  
The strobe will begin to flash.

### **How To Turn Strobe Test OFF**

1. Hold down the **3** button until two beeps are heard.  
The strobe will stop flashing.

## **4 Turning Day Alarm On and Off (New - Software Version 1.20 Onwards)**

Holding the **4** button down will turn day alarm on or off.

### **How To Turn Day Alarm ON**

1. Hold down the **4** button until three beeps are heard.  
Day alarm has now been turned on.

### **How To Turn Day Alarm OFF**

1. Hold down the **4** button until two beeps are heard.  
Day alarm has now been turned off.

If the STAY indicator is required to indicate the status of day alarm operation (enabled/disabled), refer to "LOCATION 669" on page 158 for further information.

## 5 **Fault Analysis Mode**

There are various system faults that can be detected by the control panel. When any of these are present, the FAULT indicator will begin to flash and the codepad will beep once every minute. Refer to "Fault Descriptions" on page 42 for a more detailed description on each fault type.

### **How To Determine The Type Of Fault**

1. Hold the **5** button down until two beeps are heard.  
The STAY and AWAY indicators will begin to flash in unison with the FAULT indicator. One or more ZONE indicators (1-8) will illuminate to indicate the type of fault.

### **How To Exit Fault Analysis Mode**

1. To exit fault analysis mode, press the **AWAY** button.  
The STAY and AWAY indicators will extinguish.

<b>Zone Indicator</b>	<b>Fault Description</b>
<b>1</b>	Low Battery
<b>2</b>	Date and Time
<b>3</b>	Sensor Watch
<b>4</b>	Horn Speaker Disconnected
<b>5</b>	Telephone Line Fault
<b>6</b>	E <sup>2</sup> Fault
<b>7</b>	Zone 16 In Alarm - Partitioned Systems Only
<b>8</b>	Communications Failure

*Table 24: Fault Indicators*

## 6 **Initiate A Modem Call**

Holding the **6** button down until two beeps are heard will force the control panel to dial the callback telephone number programmed in "LOCATION 032 - 047" on page 93 in an attempt to connect to the remote computer.

The remote computer will be required to be running the Alarm Link Software (CC816) and will need to be set to "Waiting For An Incoming Call". If no callback telephone number has been programmed, entering this function will have no effect.

## 7 **Reset Latching Outputs**

Holding the **7** button down until two beeps are heard will reset any programmable output that has been programmed to remain on once it has been activated.

The output will need to be programmed with a latching polarity. Refer to "Output Polarity" on page 134 for further information.

## 8 Codepad ID and Buzzer Tone Change

Holding the  button down for two seconds performs one of two functions.

The first function is to indicate the area that the codepad belongs to when the system has been partitioned.

The second function changes the tone of the codepad buzzer. There are fifty different tones to choose from between 1500 Hz and 5000 Hz and they are specific to each codepad. In a multiple codepad installation, each codepad can have a different tone.

### How To Determine The Area That The Codepad Belongs To

1. Hold the  button down until two beeps are heard.  
A ZONE indicator will illuminate. If no ZONE indicator illuminates, the codepad cannot be used when the system has been partitioned.

Z1 = Area One Codepad.

Z2 = Area Two Codepad.



Z3 = Area Three Codepad.

Z4 = Area Four Codepad.

Z7 = "CP5 Master Partitioned (CP500P)" codepad.

2. Press the  button to exit this mode.

### How To Change The Tone Of The Buzzer

1. To change the tone of the codepad buzzer, hold the  button down continuously.  
The tone of the buzzer will start to increase in pitch.
2. If the codepad is a "CP5 Area Addressable (CP500A)" codepad, or a "CP5 Master Partitioned (CP500P)" codepad, two beeps will be heard indicating the area that the codepad belongs to as in above when you determine which area that the codepad belongs to when the system has been partitioned. Shortly after hearing the two beeps, the tone of the buzzer will start to increase in pitch. (Ranges from 1500 Hz - 5000 Hz).
3. Release the  button when the desired tone has been reached.
4. Press the  button to exit this mode.

## 9 Initiate A Test Report

Holding the  button down until two beeps are heard will transmit a "Test" report which is used to test the dialling and reporting capabilities of the system without causing the sirens to sound.

A "Test" report will not be transmitted if the Subscriber ID Number is 0000. This feature is only applicable if the control panel has a dialler hybrid fitted and enabled in "LOCATION 663" on page 150.



# *Remote Operations*

---

## **This Section Includes The Following:**

- *Remote Arming Via The Telephone*
- *Operating The Control Panel Using The DTMF Command Module*
- *Upload/Download Via Alarm Link Software*

## **Remote Operations**

This section covers all aspects of operating and programming the *Solution-16* control panel other than by a remote codepad or the hand held programmer. There are a number of methods that can be used via the telephone line to gain access to the control panel. These methods will prove to be time saving and easy to perform.

### **Remote Arming Via The Telephone**

This feature allows you to arm your system from any remote location via the telephone line. For obvious security reasons, the control panel cannot be disarmed using this method. To make use of this feature, you will require the Phone Controller (CC911).

#### **How To Remotely Arm Your System Via The Telephone**

1. Call the telephone number that your control panel has been connected to.
2. When the control panel answers the incoming call, a short jingle will be heard. Hold the phone controller to the mouth piece of the telephone and press the button on the side of the unit for 3 seconds.
3. After releasing the button on the phone controller, two beeps will be heard to indicate that the system has armed in the AWAY Mode. If the control panel has been partitioned, ALL areas will arm in AWAY Mode.
4. Hang up the telephone and the system will remain armed.

If you hear a number of strange sounding tones when the control panel answers the incoming call, this means that the system has been programmed for remote programming functions. Simply wait for a pause in the tones and follow the steps above to remotely arm the system.

If the control panel does not answer the call, this means that the system may already be armed or remote functions have not been enabled. Refer to "LOCATION 663" on page 150 to enable remote arming via the telephone.

---

**Note:** Where both remote arming and Upload/Download have been selected, the control panel will answer the call expecting the remote computer. This is easily noticed as the modem negotiating tones will be heard rather than the remote arming jingle.

---

## **Operating The Control Panel Using The DTMF Command Module**

The DTMF Command Module (CC886) will allow you to operate the control panel remotely via the telephone line. Once a communications link has been established with the control panel, you can perform any system functions as you would using the codepad on a touch tone telephone. Master Code Functions, User Code Functions, Installer Code Functions and the ability to enter Installer's Programming Mode to remotely program the control panel are available options that may be performed via the telephone. Refer to "LOCATION 671" on page 160 to enable the options required to be used when using the DTMF Command Module.

The DTMF Command Module also allows domestic dialling to be acknowledged by pressing the  button on your telephone (New - Software Version 1.32 Onwards).

### **Operation - Software From Version 1.10**

#### **How To Establish A Communication Link With Your Control Panel (Non Partitioned System)**

1. Dial the telephone number that the control panel has been connected to. When the control panel answers your call, a short jingle will be heard.
2. After the jingle, press the  button on your telephone during the pause. You will then hear a second jingle. You have now established a communication link.

### **Operation - Software From Version 1.20**

#### **How To Establish A Communication Link With Your Control Panel (Non Partitioned System)**

1. Dial the telephone number that the control panel has been connected to. When the control panel answers your call, a short jingle will be heard.
2. After the jingle, press the  button on your telephone during the pause. You will then hear a second jingle. You have now established a communication link.

---

**Note:** If your control panel has been partitioned, pressing  to establish a communication link will not work.

---

**To Establish A Communication Link With Your Control Panel (Partitioned System)**

1. Dial the telephone number that the control panel has been connected to. When the control panel answers your call, you will hear a short jingle.
2. After the jingle, press the corresponding area number that you wish to establish a communication link with (ie. 1, 2, 3 or 4). You will now hear a second jingle and have established a communication link.

Once a communication link has been established with a partitioned control panel, you cannot toggle from area to area like you can on a "CP5 Master Partitioned (CP500P)" codepad. To access another area, you will need to terminate the communication link, redial the control panel and then select the required area.

You can arm and disarm all areas at the same time when linked to a partitioned control panel provided that the user code is valid for all areas and that Option 1 - "Enable User Code + 0 + AWAY Function To Arm/Disarm All Areas" has been enabled in "LOCATION 670" on page 159.

Once connected, any normal system function can be performed by simply entering the numbers on the telephone as you would from a codepad. HOLD DOWN FUNCTIONS however will not work.

While you are connected to the control panel, if a button is not pressed within a sixty second period, you will hear a jingle of decreasing pitch that will indicate that the link has been terminated.

**To Terminate The Communication Link With Your Control Panel**

1. Press the **#** button on the telephone twice to terminate the communication link. You will hear a short jingle of decreasing pitch to indicate termination of the communication link.

When Installer's Programming Mode has been entered, pressing the **#** button twice on the telephone will not terminate the call. You will need to exit Installer's Programming Mode by entering command **960** followed by the **#** button before pressing the **#** button twice to terminate the communication link.

## Upload/Download Via Alarm Link Software

The *Solution-16* control panel can be remotely programmed or controlled via an IBM or compatible personal computer via the Alarm Link Software (CC816). This facility will allow you to make alterations to your customers control panel without the need to leave your office, thus improving customer service and saving you time and money. For country locations where a control panel may be situated hundreds of kilometres from your office, the Upload/Download feature is invaluable.

When selecting the control panel type during the set up of a new customer database in the Alarm Link Software, refer to the table below to select the software version number that corresponds to the control panel type required.

<b>Control Panel's Software Version</b>	<b>Select Panel Type</b>
<i>Solution-16</i> 1.10	S16_11
<i>Solution-16</i> 1.20	S16_12
<i>Solution-16</i> 1.3x	S16_13
<i>Solution-16</i> 1.40	S16_14
<i>Solution-16</i> 2.00	S16_20

Table 25: Alarm Link Panel Forms

After selecting the correct panel type when adding a new customer in the Alarm Link Software, the Subscriber ID Number and the Installer Code will need to match that of the control panel for synchronisation when making connection to the control panel. If these two locations do not match that of the control panel, the computer and the control panel will not synchronise.

### Direct Connect

The direct connect feature has been incorporated giving the installer a simple method for programming the *Solution-16* control panel at the office. There is no need for telephone lines or modems which makes programming of the control panel completed easily in minutes. It can also be used on site visits where the installer is using a portable personal computer.

All that is required is the Direct Link Cable (CC808) connected to the relevant serial port on your IBM or compatible computer and the other end to the "Auxiliary Module" socket on the control panel.

When using the direct connect method of connecting to the control panel, Option 4 in "LOCATION 663" on page 150 does not require to be enabled. The direct connect method of connecting to the control panel will operate regardless of this option set.

---

**Note:** If the *Solution-16* has an optional Voice Module connected and enabled, the direct connect method of connecting to the control panel will not function unless Option 15 in "LOCATION 050" has been disabled and the Voice Module disabled prior to the connection being made.

---

## **Remote Connect**

The remote connect feature allows you to establish a connection through the telephone network from your IBM or compatible computer to the *Solution-16* control panel anywhere in the country where a telephone line is present. The advantages of this are very obvious and having this facility will allow you to offer faster service to your clients.

### **Remote Connect With Customer Control**

If you wish to configure the control panel so that a remote connection can only be established when the client initiates it through the remote codepad, you will need to program the following information.

"LOCATION 032 - 047" will need to have the "Callback Telephone Number" programmed and Option 4 in "LOCATION 663" on page 150 will need to be disabled. The control panel has now been set so that the client has control for when a remote connection can be established.

To cause the control panel to dial the remote computer to establish a link, hold down the  button to two seconds on the remote codepad.

### **Remote Connect Without Callback Verification**

Remote connect without callback verification can be handy where you have a need to perform Upload/Download functions from multiple locations. It should be noted that by using this feature you are reducing the security of your control panel.

"LOCATION 032 - 047" should be cleared and Option 4 in "LOCATION 663" on page 150 will need to be enabled. The control panel will now allow a connection of the first call without calling the remote computer back to make contact.

### **Remote Connect With Callback Verification**

Remote connect with callback verification offers the highest degree of data security by incorporating a two level security check.

The first is the Installer Code combined with the Subscriber ID Number needs to match that of the control panel. Secondly, the control panel will callback the programmed callback phone number to establish the valid connection. The "Callback Telephone Number" is the phone line that the modem and computer has been connected to.

"LOCATION 032 - 047" must be programmed with the "Callback Telephone Number" and Option 4 in "LOCATION 663" on page 150 will need to be enabled.

# Reporting Formats

---

## **This Section Includes The Following:**

- *Contact ID Format*
- *Event Codes*
- *Point ID Codes*
- *General Reporting Formats*
- *Securitel*
- *Securitel and Partitioning*
- *Domestic Reporting*
- *Domestic Dialling*
- *Synthesised Voice Reporting*
- *Synthesised Voice Dialling*
- *Operation Of The Voice Module*
- *Basic Pager Format Reporting*
- *PET Alpha Pager Reporting*
- *PET Alpha Pager Messages*
- *Logging System Events Via Serial Printer*

## Reporting Formats

When making use of the control panel's dialling and communication features, there are a number of transmission formats available. Refer to "LOCATION 050" on page 94 to set the required transmission format. The *Solution-16* control panel comes factory default to report in the Contact ID Format.

### Contact ID Format

This format can identify hundreds of protection zones by their unique code and provides a single digit event qualifier and a three digit event code that quickly identifies the condition being reported.

<b>Subscriber ID Number</b>	<b>Qualifier</b>	<b>Event Code</b>	<b>Group Number</b>	<b>Point ID Number</b>
<b>SSSS</b>	<b>Q</b>	<b>XYZ</b>	<b>GG</b>	<b>CCC</b>
Four Digit Subscriber ID Number	Event Qualifier, Which Gives Specific Event Information. 1 = New Event Or Opening 3 = New Restore Or Closing	Event Code (Made Up Of 3 Hex Digits)	Group Number (Made Up Of 2 Hex Digits)	Point ID Number (Made Up Of 3 Hex Digits)

*Table 26: Contact ID Format Breakdown*

In general, Contact ID reporting format is very simple as most of the Event Codes and Point ID Codes have been predefined. The Event Code is programmable whereas the Point ID Codes are fixed. The base station software usually only has the ability to identify a zone going into alarm by its Point ID Code and usually pays little attention to the Event Code.

Refer to "Table 28: Point ID Codes" on page 74 for further information on the *Solution-16* Point ID Codes and "Table 27: Contact ID Event Codes" on page 73 for the list of Event Codes that are supported by the control panel.



**Event Codes**

<b>Event</b>	<b>Description</b>	<b>Event</b>	<b>Description</b>	<b>Event</b>	<b>Description</b>
<b>Medical Alarms</b>		<b>24 Hour Non Burglary</b>		<b>Peripheral Troubles</b>	
100	Medical	150	25 Hour Non Burg	330	System Peripheral
101	Pendant Transmitter	151	Gas Detected	331	Polling Loop Open
102	Fail To Report In	152	Refrigeration	332	Polling Loop Short
<b>Fire Alarms</b>		153	Loss Of Heat	333	Exp Module Failure
110	Fire Alarm	154	Water Leakage	334	Fail To Communicate
111	Smoke	155	Foil Break	335	Lcl Printer Paper Out
112	Combustion	156	Day Trouble	336	Local Printer Failure
113	Water Flow	157	Bottled Gas Low	<b>Comms Trouble</b>	
114	Heat	158	High Temperature	344	RF Jamming
115	Pull Station	159	Low Temperature	350	Communication
116	Duct	161	Loss Of Air Flow	351	Telecom Line 1 Fail
117	Flame	<b>Fire Supervisory</b>		352	Telecom Line 2 Fail
118	Near Alarm	200	Fire Supervisory	353	Long Radio TX Fail
<b>Panic Alarms</b>		201	Low Water Pressure	354	Fail To Communicate
120	Panic Alarm	202	Low CO2	355	Loss Of Radio Super
121	Duress Alarm	203	Gate Valve Sensor	356	Loss Of Central Poll'g
122	Silent Alarm	204	Low Water Level	<b>Protection Loop Trouble</b>	
123	Audible Alarm	205	Pump Activated	370	Protection Loop
<b>Burglary Alarms</b>		206	Pump Failure	371	Protection Loop Open
130	Burglary	<b>System Troubles</b>		372	Protection Loop Short
131	Perimeter	300	System Trouble	373	Fire Trouble
132	Interior	301	AC Loss	<b>Sensor Troubles</b>	
133	24 Hour	302	Low System Battery	380	Sensor Trouble
134	Entry/Exit	303	RAM Checksum Bad	381	Loss Of Super - RF
135	Day/Night	304	ROM Checksum Bad	382	Loss Of Super - RPM
136	Outdoor	305	System Reset	383	Sensor Tamper
137	Tamper	306	Panel Program Altered	384	RF XMTR Low Battery
138	Near Alarm	307	Self Test Failure	<b>Access Control</b>	
<b>General Alarms</b>		308	System Shutdown	421	Access Denied
140	General Alarm	309	Battery Test Failure	<b>Zone Bypass</b>	
141	Polling Loop Open	310	Ground Fault	570	Zone Bypass
142	Polling Loop Short	<b>Sounder Relay Troubles</b>			
143	Exp'n Module Fail	320	Sounder/Relay		
144	Sensor Tamper	321	Bell 1		
145	Exp'n Module Tamper	322	Bell 2		
		323	Alarm Relay		
		324	Trouble Relay		
		325	Reversing		
				602	Test

Table 27: Contact ID Event Codes

## Point ID Codes

Point ID	Event Description	Event Code	Explanation	Page
<b>Zone Specific</b>	Burglary Zones 1-7 and 9-16	130	Burglary	104
<b>Zone Specific</b>	Burglary Zone 8 (24 Hour)	133	24 Hour Burglary	104
<b>User Specific</b>	Open/Close	401 Fixed	Opening - User ## Closing - User ##	120
<b>User Specific</b>	Open/Close (Partitioned)	402 Fixed	Opening - Group - User ## Closing - Group - User ##	173
<b>030</b>	AC Mains Fail	301	AC Power	118
<b>031</b>	Low Battery	309	Battery Test Failure	119
<b>040</b>	Duress Alarm	121	Codepad Duress Alarm	116
<b>041</b>	Panic Alarm	120	Codepad Panic Alarm	117
<b>042</b>	Access Denied	421	Code Retry Exceeded	118
<b>043</b>	Program Change	306	Programming Information Changed	119
<b>044</b>	Test Report	602 Fixed	Test Report	122
<b>045</b>	Medical Alarm	100 Fixed	Codepad Medical Alarm (New - 1.37)	117
<b>046</b>	Fire Alarm	110 Fixed	Codepad Fire Alarm (New - 1.37)	117
<b>048</b>	RF Fail	353	Safecom communication Failure (New – 2.00)	121
<b>049</b>	Telco Fail	351	Telephone Line Failure (New – 2.00)	121
<b>050</b>	RF Jamming	344	Constant Carrier Detected (New – 2.00)	121
<b>Zone Specific</b>	Sensor Watch	307 Fixed	Sensor Tamper (1.10 Only)	120
<b>Zone Specific</b>	Sensor Watch	307 Fixed	Sensor Tamper (1.20 Onwards)	120
<b>Zone Specific</b>	Zone Trouble	380 Fixed	Zone Unsealed After End Of Exit Time	115
<b>Zone Specific</b>	Zone Bypass	570 Fixed	Zone Manually Isolated	114

Table 28: Point ID Codes

This table shows the different Point ID Codes and Event Codes that are transmitted to the base station receiver when using Contact ID Reporting Format. Some event codes are fixed while others are user definable. The event codes that are fixed will always transmit the same code as there are no programming locations made available to alter these. The other event codes may be changed when required.

### Example

If zone 8 is being used as a 24 hour medical alarm rather than a 24 hour burglary, its event code may be changed from Event Code 133 (24 Hour Burglary) and instead programmed as Event Type 100 (Medical).

---

**Note:** Before changing any event codes, consult your base station supervisor to ensure that you select the correct code.

---

## General Reporting Formats

The following formats may be designated to report in either Standard or Extended Formats. In all cases, the standard format will report to the central monitoring station a Subscriber ID Number followed by an Alarm, Trouble, Restore or Open/Close codes.

The Expanded 3+1 and Expanded 4+1 Formats will report a Subscriber ID Number followed by an Expansion Code, followed by a second line where the Expansion Code is repeated as the Subscriber ID Number followed by the Reporting Channel (Or User ID) relevant to that report.

If 4+2 Format is selected then no second line is transmitted and the reporting channel number is transmitted directly after the expansion code.

<b>Event</b>	<b>3+1/4+1 Universal</b>	<b>3+1/4+1 Expanded</b>	<b>4+2</b>
Alarm	SSS (S) A	SSS (S) A AAA (A) C <sub>H</sub>	SSSS AC <sub>H</sub>
Trouble	SSS (S) T	SSS (S) T TTT (T) C <sub>H</sub>	SSSS TC <sub>H</sub>
Bypass	SSS (S) B	SSS (S) B BBB (B) C <sub>H</sub>	SSSS BC <sub>H</sub>
AC Fail	SSS (S) E	SSS (S) E EEE (E) A <sub>C</sub>	SSSS EA <sub>C</sub>
Low Battery	SSS (S) L	SSS (S) L LLL (L) L <sub>B</sub>	SSSS LL <sub>B</sub>
Open	SSS (S) O	SSS (S) O OOO (O) U	SSSS OU
Close	SSS (S) C	SSS (S) C CCC (C) U	SSSS CU
Test	SSS (S) T <sub>E</sub>	SSS (S) T <sub>E</sub>	SSSS T <sub>E</sub> O
Program Altered	SSS (S) P	SSS (S) P	SSSS P <sub>0</sub>
Duress	SSS (S) D	SSS (S) D	SSSS DD <sub>0</sub>
<b>Restore</b>	<b>3+1/4+1 Universal</b>	<b>3+1/4+1 Expanded</b>	<b>4+2</b>
Alarm	SSSS (S) R	SSS (S) R RRR (R) C <sub>H</sub>	SSSS R CH
Trouble	SSS (S) T <sub>R</sub>	SSS (S) T <sub>R</sub> T <sub>R</sub> T <sub>R</sub> T <sub>R</sub> (T <sub>R</sub> ) C <sub>H</sub>	SSSS T <sub>R</sub> C <sub>H</sub>
Bypass	SSS (S) B <sub>R</sub>	SSS (S) B <sub>R</sub> B <sub>R</sub> B <sub>R</sub> B <sub>R</sub> (B <sub>R</sub> ) C <sub>H</sub>	SSSS B <sub>R</sub> C <sub>H</sub>
AC Fail	SSS (S) E <sub>R</sub>	SSS (S) E <sub>R</sub> E <sub>R</sub> E <sub>R</sub> E <sub>R</sub> (E <sub>R</sub> ) A <sub>CR</sub>	SSSS E <sub>R</sub> A <sub>CR</sub>
Low Battery	SSS (S) L <sub>BR</sub>	SSS (S) L <sub>BR</sub> L <sub>BR</sub> L <sub>BR</sub> L <sub>BR</sub> (L <sub>BR</sub> ) L <sub>B</sub>	SSSS L <sub>BR</sub> L <sub>B</sub>

Table 29: General Reporting Formats

<b>Code</b>	<b>Description</b>	<b>Code</b>	<b>Description</b>
<b>SSSS</b>	Subscriber ID Number	<b>R</b>	Alarm Restore Code
<b>A</b>	Alarm	<b>T<sub>R</sub></b>	Trouble Restore Code
<b>C<sub>H</sub></b>	Channel Number	<b>B<sub>R</sub></b>	Bypass Restore Code
<b>0</b>	Zero	<b>E<sub>R</sub></b>	AC Fail Restore Code 1 <sup>st</sup> digit
<b>T</b>	Trouble	<b>A<sub>CR</sub></b>	AC Fail Restore Code Second Digit
<b>B</b>	Bypass	<b>L<sub>R</sub></b>	Low Battery Restore Code 1 <sup>st</sup> Digit
<b>E</b>	AC Fail Code 1 <sup>st</sup> Digit	<b>L<sub>BR</sub></b>	Low Battery Restore Code 2 <sup>nd</sup> Digit
<b>A<sub>C</sub></b>	AC Fail Code 2 <sup>nd</sup> Digit	<b>D</b>	Duress Code 1 <sup>st</sup> Digit
<b>L</b>	Low Battery Code 1 <sup>st</sup> Digit	<b>D<sub>0</sub></b>	Duress Code 2 <sup>nd</sup> Digit
<b>L<sub>B</sub></b>	Low Battery Code 2 <sup>nd</sup> Digit	<b>P</b>	Panic Code 1 <sup>st</sup> Digit
<b>O<sub>P</sub></b>	Open	<b>P<sub>CH</sub></b>	Panic Code 2 <sup>nd</sup> Digit
<b>C<sub>P</sub></b>	Close	<b>T<sub>P</sub></b>	Test Code
<b>U</b>	User Number		

*Table 30: 3+1/4+1 Transmission Code Descriptions*

## Securitel

The *Solution-16* control panel can communicate to base stations via the Securitel Network using an EDMSTU (CS800). Not all messages can be transmitted via securitel as they can via the communication dialler transmitting in Contact ID Format. Refer to "Table 31: Securitel Reporting Messages" below for the list of messages that are supported by securitel.

<b>Event</b>	<b>Location</b>	<b>Page No</b>
<b>Alarms and Restores</b>	340 - 467	104
<b>Zone Bypass Reports *</b>	468 - 471	114
<b>Zone Trouble Reports *</b>	472 - 475	115
<b>Open/Close Reports</b>	504 - 505	120
<b>AC Fail</b>	488 - 491	118
<b>Low Battery</b>	492 - 495	119
<b>Codepad Panic</b>	480 - 483	117
<b>Codepad Duress</b>	476 - 479	116
<b>Codepad Tamper</b>	484 - 487	118

*Table 31: Securitel Reporting Messages*

**Note:** Zone bypass and zone trouble reports are not transmitted separately. They are transmitted as one combined isolate report.

## How To Program and Setup Securitel

To connect and setup the EDMSTU, follow the procedures below:

1. Program the Subscriber ID Number in "LOCATION 052 - 055".
2. Program Output 2 as all zero's in "LOCATION 546 - 552".
3. Disable Option 1 in "LOCATION 663" if the control panel is not going to use the on-board dialler.
4. Connect the EDMSTU to the *Solution-16* control panel using the table below.
5. Once the EDMSTU has been connected to the control panel, the EDMSTU will now need to be 'upped' by the monitoring station.

<b>Solution-16</b>	<b>EDMSTU</b>
<b>Output 2</b>	D
<b>GND</b>	-
<b>+ COM</b>	+

*Table 32: EDMSTU Connection Terminals*

Refer to your EDMSTU Installation Manual for further information.

## Securitel and Partitioning

The EDMSTU (CS800) was not designed to transmit individual Open/Close Reports for each area via the Securitel Network. It will however transmit "First To Open/Last To Close Reporting" if Option 2 in "LOCATION 664" has been enabled.

## Domestic Reporting

The "Primary Telephone Number" and the "Secondary Telephone Number" locations which are normally used for base station reporting can be added together making provision to store up to 32 digits. The 32 data locations are now used to store any number of telephone numbers and subject to the length of each of the telephone numbers it is possible to store 3 or more different telephone numbers for Domestic Dialling Format.

### Programming Domestic Reporting

Programming the control panel for "Domestic Reporting" has been made extremely simple by the use of the Installer's Programming Command 965. Refer to "Installers Programming Commands" on page 23 for more information.

#### How To Set Up The Control Panel For Domestic Dialling

1. Enter Installer's Programming Mode (EG: **1 2 3 4** followed by the **AWAY** button).  
Two beeps will be heard and the STAY and AWAY indicators will begin to flash.
2. Enter Command **9 6 5** followed by the **AWAY** button.  
Two beeps will be heard. The control panel has now been set up for Domestic Dialling Format.
3. Exit Installer's Programming Mode by entering Command **9 6 0** followed by the **AWAY** button.  
Two beeps will be heard and the STAY and AWAY indicators will extinguish.
4. To program your telephone numbers, enter the **MASTER CODE** followed by **2** and the **AWAY** button.  
Three beeps will be heard and the STAY and AWAY indicators will begin to flash. Refer to "Master Code Functions" on page 50 for more information.

If there are telephone numbers already programmed, they will be displayed one digit at a time via the ZONE indicators on the codepad.

If there are no previous programmed telephone numbers, a further two beeps will be heard after entering this mode. These two beeps are normally heard after the last digit of the last telephone number has been displayed.

5. Enter all the digits for **PHONE No. 1**, one digit at a time. You will notice as each digit is entered, the corresponding codepad indicators will illuminate.
6. After you have entered all the digits of the first telephone number press the **STAY** button if there is more than one phone number. This will insert a break between the first telephone number and the second telephone number. If there is only one phone number, press the **AWAY** button to exit this mode.
7. Enter all the digits for **PHONE No. 2**, one digit at a time. You will notice as each digit is entered, the corresponding codepad indicators will illuminate.
8. After the last digit of the second telephone number, press the **AWAY** button to exit this mode unless a third telephone number is required.

Your control panel has now been set up to report in the Domestic Dialling Format. Test the dialling functions by triggering the control panel to report to your programmed telephone numbers.

#### How To Disable Domestic Dialling Using The Master Code

If at any time the Master Code holder wishes to cancel domestic dialling for any reason (eg. They are moving house and they do not wish the system to continue calling their place of work or mobile phone etc), they can enter the **MASTER CODE** followed by **2** and then the **AWAY** button, the **STAY** button and the **AWAY** button to disable domestic dialling.

**MASTER CODE** + **2** + **AWAY** + **STAY** + **AWAY**

## **Domestic Dialling Operation**

When the control panel has activated into alarm condition, it will commence dialling the first programmed telephone number. If a busy or engaged tone has been detected, the control panel will hang up and commence dialling the second telephone number (if one is programmed). The first call however will be counted as one unsuccessful dialling attempt. If the second telephone number is also busy or an engaged tone is detected, the control panel will hang up and commence dialling the third telephone number (if one is programmed).

If a busy tone is not detected, the control panel will assume that the phone has been answered and will begin sending its transmission. The transmission consists of a siren tone followed by a unit identification beep. The identification beep will allow the customer to verify which control panel made the call if more than one control panel is reporting to the same telephone number. The identification beep is programmed in "LOCATION 55" of the Subscriber ID Number.

---

**Note:** A maximum of 6 calls per alarm event will be made when the control panel has been set up for "Domestic Dialling Format". This count includes any unsuccessful calls. The counter will be reset if the zone retriggers and a further 6 attempts will be made. The control panel will stop dialling after 6 attempts or 3 successful calls. The control panel will also stop dialling if a valid user code has been entered at the remote codepad.

---

## **Acknowledge Domestic Dialling**

Once the call has been received, if it is not acknowledged using a Phone Controller (CC911), the control panel will continue to send its transmission for a period of 2 minutes. It will then hang up and commence dialling the next telephone number. If the call is acknowledged, the control panel will hang up and no further calls will be made for that event.

---

**Note:** From Software Version 1.32 onwards, you can acknowledge the call by pressing the  button on your telephone without the DTMF Command Module (CC886) connected.

For Software Version 1.10 - 1.31, the DTMF Command Module will need to be connected to your control panel to acknowledge Domestic Dialling by pressing the  button on your telephone.

---

## Synthesised Voice Reporting

The Voice Module (CC888) has been designed so that a clear concise voice message can be transmitted by the control panel to the telephone numbers of your choice when an alarm condition occurs. This allows the person receiving your call to easily understand that the alarm at your home or office has been activated and that action is required. This voice message is pre-recorded and can be changed as many times as necessary. The message can be from between 1-16 seconds in length.

There is no longer a need to put up with having to decipher alarm tones and trying to explain to your relatives just what the tones actually mean. A recorded message is perfect as it can easily be interpreted by any person receiving the call and therefore immediate action can be taken according to your specific message. The voice message can be recorded in any language and once programmed, it will be retained indefinitely irrespective of power loss. No messy batteries are required.

### How To Set Up The Control Panel For Synthesised Voice Format

1. Enter Installer's Programming Mode (EG: **1****2****3****4** followed by the **AWAY** button).  
Two beeps will be heard and the STAY and AWAY indicators will begin to flash.
2. Enter Command **9****6****5** followed by the **AWAY** button.  
Two beeps will be heard. The control panel has now been set up for Domestic Dialling Format.
3. Enable "Synthesised Voice Format" by programming "LOCATION 050" as 15.
4. Exit Installer's Programming Mode by entering Command **9****6****0** followed by the **AWAY** button.  
Two beeps will be heard and the STAY and AWAY indicators will extinguish.
5. To program your telephone numbers, enter the **MASTER CODE** followed by **2** and the **AWAY** button. Three beeps will be heard and the STAY and AWAY indicators will begin to flash. Refer to "Master Code Functions" on page 50 for more information.

If there are telephone numbers already programmed, they will be displayed one digit at a time via the ZONE indicators on the codepad.

If there are no previous programmed telephone numbers, a further two beeps will be heard after entering this mode. These two beeps are normally heard after the last digit of the last telephone number has been displayed.

6. Enter all the digits for **PHONE No. 1**, one digit at a time. You will notice as each digit is entered, the corresponding codepad indicators will illuminate.
7. After you have entered all the digits of the first telephone number press the **STAY** button if there is more than one phone number. This will insert a break between the first telephone number and the second telephone number. If there is only one phone number, press the **AWAY** button to exit this mode.
8. Enter all the digits for **PHONE No. 2**, one digit at a time. You will notice as each digit is entered, the corresponding codepad indicators will illuminate.
9. After the last digit of the second telephone number, press the **AWAY** button to exit this mode unless a third telephone number is required.

Your control panel has now been set up to report in Synthesised Voice Format. Test the dialling functions by triggering the control panel to report to your programmed telephone numbers.



## **How To Disable Synthesised Voice Dialling Using The Master Code**

If at any time the Master Code holder wishes to cancel Synthesised Voice dialling for any reason (eg. They are moving house and they do not wish the system to continue calling their place of work or mobile phone etc), they can enter the **MASTER CODE** followed by **2** and then the **AWAY** button, the **STAY** button and the **AWAY** button to disable domestic dialling.



## **Synthesised Voice Dialling Operation**

When the control panel has activated into alarm, it will commence dialling the first programmed telephone number. If a busy or engaged tone has been detected, the control panel will hang up and commence dialling the second telephone number (if one is programmed). The first call however will be counted as one unsuccessful dialling attempt. If the second telephone number is also busy or an engaged tone is detected, the control panel will hang up and commence dialling the third telephone number (if one is programmed).

If a busy tone is not detected, the control panel will assume that the phone has been answered and will begin sending its transmission. The transmission consists of the recorded voice message repeating itself for a period of about 90 seconds followed by two beeps.

---

**Note:** A maximum of 6 calls per alarm event will be made when the control panel has been set up for "Synthesised Voice Dialling Format". This count includes any unsuccessful calls. The counter will be reset if the zone retriggers and a further 6 attempts will be made. The control panel will stop dialling after 6 attempts or 3 successful calls or a user code has been entered from the remote codepad.

---

## **How To Acknowledge Synthesised Voice Dialling Without DTMF Command Module Fitted**

Once the call has been received, if the call is not acknowledged once the message has completed by pressing the button on the Phone Controller (CC911) for three seconds or alternatively by pressing the **\*** button on the touch tone telephone for 3 seconds, the control panel will commence dialling the next telephone number. If the call has been acknowledged, the control panel will hang up and no further calls will be made for that event.

## **How To Acknowledge Synthesised Voice Dialling With DTMF Command Module Fitted**

Once the call has been received, if the call is not acknowledged by pressing the **#** button on the telephone at any time during the message playback, the control panel will then hang up after the message has completed and commence dialling the next telephone number. If the call has been acknowledged, the control panel will hang up and no further calls will be made for that event.

## **Operation Of The Voice Module**

The unit has two modes of operation being:

1. Record Mode - Crystal Earpiece Not Plugged In.
2. Replay Mode - Crystal Earpiece Plugged In.

### **Recording The Voice Message**

In the RECORD mode, the crystal earpiece should not be connected. To record a message on the voice module, press and hold the Record/Play switch. At the same time commence speaking into the microphone slowly and clearly dictating your desired message.

The status indicator will illuminate as the Record/Replay switch is pressed and will remain on while ever the switch is being held in or until the maximum recording time of 16 seconds has expired. If your message is less than 16 seconds long, simply release the switch to stop recording.

For good recording results, keep all background noise to a minimum and speak clearly into the microphone approximately 30 cm away.

---

### **WARNING**

**Do not press the Record/Play switch without the earpiece connected unless you want to record.  
If you do, the current message will be erased and a new message recorded.**

---

### **Replay The Voice Message**

There are two different Replay modes available. One is to check the message and the other is used during an alarm condition.

The first replay mode is to check the message with the crystal earpiece connected. By pressing the Record/Replay switch once, the voice module will replay the message it currently has stored so that it can be checked for accuracy and clarity. This mode will automatically terminate as soon as the programmed message has been completely replayed.

The second replay mode occurs when an alarm condition occurs and the control panel that the voice module is connected to dials the programmed telephone numbers. This can be achieved by triggering a zone or by sending a test report. Once triggered, the control panel will dial the programmed telephone number and commence playing its recorded voice message.

The message consists of a 90 second period during which time the recorded voice message will be repeated continuously. The 90 second timer commences as soon as the last digit of the telephone number has been dialled. At the end of the 90 seconds, the control panel will send two beeps followed by a pause. This will be repeated over a 20 second period. During this pause, the control panel looks for an acknowledge tone. If it is received within the next 20 seconds, the control panel will hang up and make no further calls.

### Connection Of The Voice Module

The Voice Module plugs onto the AUXILIARY MODULE socket on the control panel. Please ensure that all power to the control panel has been removed before connecting the voice module. Remember to align the arrows on the voice module to those on the control panel. Reconnect the power to the control panel once the voice module has been connected correctly.

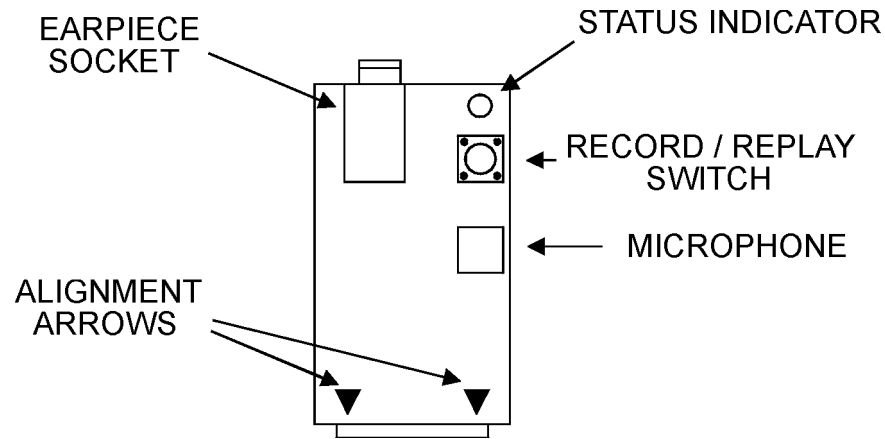

*Figure 2: Diagram Of EDM Voice Module (CC888)*

### Basic Pager Format Reporting

Basic Pager Format requires some interpretation of the numbers that appear on the display, however, it is possible to differentiate between 1000 different control panels when a number of control panels are reporting to the one pager.

To use this feature, you will require to program the following software options.

1. "LOCATION 000 - 015" requires the Basic Pager's access telephone number programmed.
2. "LOCATION 049" requires "Option 5 - Pager Handshake" to be programmed.
3. "LOCATION 050" requires "Option 12 - Basic Pager Reporting" to be programmed.

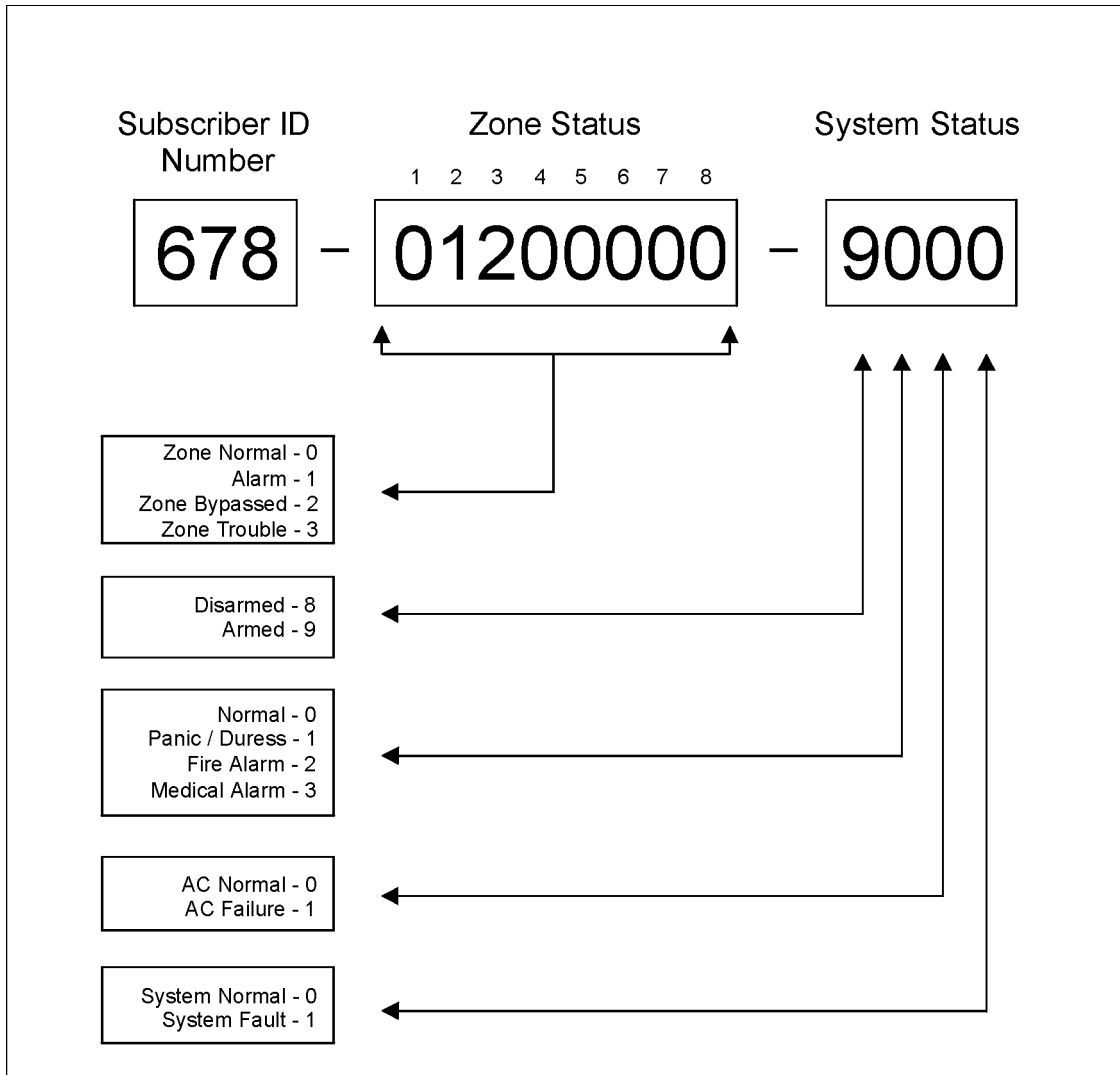

Figure 3: Basic Pager Display

The example in "Figure 3: Basic Pager Display" shows that the transmission has come from Subscriber ID Number 678 and that Zone 2 is in alarm, Zone 3 has been manually isolated, the system is armed, the panic zone is normal, the AC is connected and there is no fault condition.

---

**Note: Basic Pager Format Only Supports Zones 1-8**

---

## PET Alpha Pager Reporting

The *Solution-16* control panel is capable of transmitting PET Alpha characters at the rate of 300 baud to a pocket pager using the PET Protocol (Page Entry Terminal). Using this method of reporting will allow people who are on the move to monitor burglary alarms, medical alarms, refrigeration alarms and virtually any other event that can be used to trigger the *Solution-16* control panel.

### Programming and Hardware Requirements

To use PET Alpha Pager Reporting Format, the following programming and hardware options are required.

1. The EDM Modem Module (CC811 or CC811B) will be required to be fitted to the AUXILIARY MODULE socket on the control panel.

---

**Note:** Some pager companies use the BELL communication frequencies and others use the CCITT frequencies. It is important to obtain this information from the pager company so that you can connect the appropriate modem module for the format used. Use EDM Modem Module (CC811) for Telecom Paging CCITT frequencies and (CC811B) for BELL frequencies.

---

2. The "Primary Telephone Number" in "LOCATION 000 - 015" will require the PET Alpha Pager's Access Telephone Number.
3. Option 5 - "Pager Reporting" in "LOCATION 049" will need to be enabled.
4. Option 14 - "Alpha Pager" in "LOCATION 050" will need to be enabled.
5. "LOCATION 514 - 529" requires the PET Alpha Pager's network password.
6. "LOCATION 530 - 539" requires the 7 digit Alpha Pager ID Number.

---

**Note:** All Contact ID Event Codes will require any ZERO in the Event Code to be programmed to other than zero. If the Event Code has a zero, the report for that event will not transmit to the PET Alpha Pager.

---

The *Solution-16* only communicates to the PET Network at the rate of 300 BAUD.

---

### Telecom Access Telephone Numbers

Each state has different access numbers to the PET Network. The access telephone numbers to the Telecom Paging Networks for CCITT frequencies are as follows:

<i>State</i>	<i>Access Number</i>	<i>State</i>	<i>Access Number</i>
NSW	02 9 281 9255	VIC/TAS	03 9 510 4451
QLD	07 3 891 6824	SA/NT	08 231 1493
WA	09 321 3528		

Table 33: Telecom Access Telephone Numbers

### PET Alpha Pager Messages

This transmission format is the most informative method of reporting alarm activity to the end user. When using the PET Alpha Pager Format, the control panel will transmit all alarm information using English language messages. Once the alarm message has been received on the pager, appropriate action can be taken.

The following table lists the events that will cause the control panel to transmit to the PET Alpha Pager and the messages that will be displayed on the pager.

<b>Event At Panel</b>	<b>Pager Message</b>
AC Fail	AC Fail
AC Restore	AC Restore
Area Has Been Armed	Close Area #, User #
Area Has Been Disarmed	Open Area #, User #
Burglary Zone Has Triggered	Alarm Zone #
Burglary Zone Has Restored	Restore Zone #
Burglary Zone Has Triggered, Area #	Alarm Zone #, Area #
Burglary Zone Has Restored, Area #	Restore Zone #, Area #
Codepad Tamper - Code Retries Exceeded	Codepad Tamper
Data Programming Change	Data Change
System Has Been Armed	Close User #
System Has Been Disarmed	Open User #
Codepad Duress	Duress, Open User #
Low Battery	Low Battery
Low Battery Restored	Battery Restored
Codepad Panic Alarm	Panic
Codepad Fire Alarm (Version 1.37 Onwards)	Fire
Codepad Medical Alarm (Version 1.37 Onwards)	Medical
RF Jamming (Version 2.00 Onwards)	RF Jam
RF Fail (Version 2.00 Onwards)	RF Fail
Telco Fail (Version 2.00 Onwards)	Telco Fail
Test Report	Test
Zone Automatically Isolated When Armed	Bypass Zone #
Disarming When Zones Have Been Isolated	Bypass Restore Zone #
Zone Unsealed At End Of Exit Time	Trouble Zone #
Zone Has Resealed After End Of Exit Time	Trouble Restore Zone #
24 Hour Zone Triggered	24 Hour Alarm #
24 Hour Zone Restored	24 Hour Restore #
24 Hour Fire Zone Triggered	Fire Zone #
24 Hour Fire Zone Restored	Fire Restore #

Table 34: Alpha Pager Messages

The # symbol represents the zone number or user code number in the transmission.

The following example shows how a single transmission will be received on the PET Alpha Pager. A similar message to the one below will be seen when user 1 has armed the system.

<b>Subscriber ID Number</b>	<b>System Armed</b>	<b>User</b>
1111	CLOSE USER	01

Table 35: Example Of PET Alpha Pager Transmission

**PET Alpha Pager Password****LOCATION 514 - 529**

7	0	6	1	7	3	7	3	7	7	6	4	0	0	0	0
---	---	---	---	---	---	---	---	---	---	---	---	---	---	---	---

A provision has been made in the PET protocol for a mandatory six digit ASCII character password to be transmitted before the alarm message is transmitted. However, at the time of writing this manual, neither Telecom nor Hutchinson are making full use of this feature. There is however an important difference in what both organisations expect to see as the password for all pagers at the present time.

Telecom expect to see the password "passwd" sent before the message is transmitted. The password is programmed using ASCII text.

**Example**

To communicate with Telecom, program "70, 61, 73, 73, 77, 64" as the password.

**ASCII Characters**

<b>ASCII</b>	<b>Character</b>	<b>ASCII</b>	<b>Character</b>	<b>ASCII</b>	<b>Character</b>
30	0	4C	L	67	g
31	1	4D	M	68	h
32	2	4E	N	69	i
33	3	4F	O	6A	j
34	4	50	P	6B	k
35	5	51	Q	6C	l
36	6	52	R	6D	m
37	7	53	S	6E	n
38	8	54	T	6F	o
39	9	55	U	70	p
41	A	56	V	71	q
42	B	57	W	72	r
43	C	58	X	73	s
44	D	59	Y	74	t
45	E	5A	Z	75	u
46	F	61	a	76	v
47	G	62	b	77	w
48	H	63	c	78	x
49	I	64	d	79	y
4A	J	65	e	7A	z
4B	K	66	f		

Table 36: ASCII Character Table

### Converting ASCII Characters To Hexadecimal

To program an ASCII letter character and convert that to a number to be programmed, refer to "Table 37: Hexadecimal Conversion Table" for converting letters and numbers to decimal numbers.

#### Example

If you need to program an Alpha Pager Password with the letter 'L' in upper case, you would then program that letter as: 4,12.

<b>Hexadecimal Conversion Table</b>	
<i>Hexadecimal Number</i>	<i>Decimal Number</i>
<b>A</b>	10
<b>B</b>	11
<b>C</b>	12
<b>D</b>	13
<b>E</b>	14
<b>F</b>	15

Table 37: Hexadecimal Conversion Table

### **PET Alpha Pager ID Number**

LOCATION 530 - 539

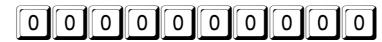

The Pager ID Number locations are used to store the unique number which allows the network to identify individual pagers.

To program the Pager ID Number, enter the decimal characters that represent the Pager ID Number. Remember to substitute a 10 for a zero and to terminate the number with a zero as you would if you were programming the telephone numbers.

---

**Note:** If the Pager ID Number is less than 7 digits, it must be prefixed with the digit 6 until the number of digits equal 7. This is only relevant when using the PET format.

---

#### Example

If the Pager ID Number is 123456, it must be programmed as 6123456.



## Logging System Events Via Serial Printer

A serial printer can be connected to the control panel to report all events that have occurred. The logging of an event will include the time and date along with a description of the event that occurred.

The serial printer is required to be connected to Output 3 and programmed as follows:

**OUTPUT 3 -** LOCATION 552 - 557



Select the required baud rate that the printer is to communicate at with the control panel.

### Printer Output Baud Rate

**LOCATION 756**



Option	Printer Baud Rate
1	300 BPS
2	600 BPS
3	1200 BPS
4	2400 BPS

Table 38: Location 756 Option Bits

Refer to "Table 41: Serial Printer Messages" on page 90 for a full list of events that will be logged by the serial printer connected to output 3.

Additional Messages When System Has Been Partitioned	
Zone # On Area # Triggered Into Alarm	Alarm Zone # Area #
Zone # On Area # Restored	Alarm Restore Zone # Area #
Area # Armed	Area # Armed By User #
Area # Disarmed	Area # Disarmed By User #
Zone Bypassed In Area #	Bypass Zone # Area #
Zone Bypass Restore In Area #	Bypass Restore Zone # Area #
Zone Trouble In Area #	Trouble Zone # Area #
Zone Trouble Restore In Area #	Trouble Zone Restore # Area #

Table 39: Additional Serial Printer Messages When Partitioned

The # symbol represents the zone or area number in the transmission.

The following example shows how a single transmission will be displayed via the serial printer connected to output 3. A similar message to the one below will be seen when the alarm system is armed by user 1.

Date	Time	Event
09/12/96	12:30:42	System Armed By User #

Table 40: Example Serial Printer Log Report

For the wiring diagram for the 25 Pin Logging Printer and the 9 Pin Printer please refer to Figure 18,19 Page 197.

<b>System Event</b>	<b>Printer Log Report</b>
Set Date and Time	Time Altered By User #
Enter Installer's Programming Mode	Entering Installer's Mode
Communications Failure	Comms Fail
Change Programming Information	Eprom Data Changed
Exit Installer's Programming Mode	Exit Installer's Mode
System Armed	System Armed By User #
System Disarmed	System Disarmed By User #
Zone Triggered	Alarm Zone #
Zone Restored	Restore Zone #
Auto Operation Of Output	Auto Operating Output
Auto Arm	System Armed By User 32
Auto Arm Pre-Alert Warning	Initiating Auto Arm Sequence
Incoming Alarm Link Call	Answering Incoming Call
Alarm Link Connection	Opened Alarm Link Session
Terminate Alarm Link Session	Closed Alarm Link Session
AC Fail	Mains Failure
AC Restore	Mains Restore
Low Battery	Battery Failed Load Test
Low Battery Restore	Battery Passed Load Test
Codepad Medical Alarm	Medical Codepad Alarm
Codepad Fire Alarm	Fire Codepad Alarm
Codepad Panic Alarm	Panic Codepad Alarm
Codepad Duress Alarm	Duress Codepad Alarm
Telephone Line Fault	Phone Line Failure
Telephone Line Restore	Phone Line Restore
No Handshake	Handshake Failure
Zone Bypass	Bypass Zone #
Zone Bypass Restore	Bypass Restore Zone #
Zone Trouble	Trouble Zone #
Zone Trouble Restore	Trouble Zone Restore #
Sensor Watch Fault	Sensor Watch Alert Zone #
Test Report	Test Report Requested
Request To Call Remote Computer	Request To Call Alink Received
Dialling Callback Telephone Number	Dial Call Back Number
Access Denied	Access Denied Alert
Printer Congested	Printer Congested
Satellite Siren Service Mode - On	Satellite Siren Off Line
Satellite Siren Service Mode - Off	Satellite Siren On Line
Dialling Primary Telephone Number	Dialling Primary Number
Dialling Secondary Telephone Number	Dialling Secondary Number
Horn Speaker Has Been Disconnected	Siren Disconnected
Horn Speaker Has Been Reconnected	Siren Reconnected
No Kiss Off Received	Kiss Off Failure
No Handshake Received	Handshake Failure
Battery Falls Below 10.5V With No AC	Low Battery Detected
System Has Been Defaulted	System Defaulted
Copying Information From Key To Panel	Solution Key Uploaded

*Table 41: Serial Printer Messages*

# ***Base Station Information***

---

## **This Section Includes The Following:**

- *Base Station Information*
- *Primary Telephone Number*
- *Secondary Telephone Number*
- *Callback Telephone Number*
- *Dialling Format*
- *Handshake Tone*
- *Transmission Format*
- *Transmission Speed*
- *Subscriber ID Number*
- *Ring Count*

## Base Station Information

This section outlines the programming information required for the *Solution-16* control panel when communicating with base station receivers. Typically these parameters specify the telephone numbers to call, the transmission formats, handshake tones and transmission speeds.

### How To Program A Phone Number

When programming the telephone number, if a '0' is required, it must be programmed as a '10'. Each location in the primary, secondary and callback telephone numbers hold one digit of the telephone number.

#### Example

To program the telephone number 9 672 1055, you would program 

9	6	7	2	1	10	5	5
---	---	---	---	---	----	---	---

.

### Programming The End Of A Phone Number

To tell the dialler when the end of the telephone number has been reached, a '0' must be inserted at the end of the telephone number. Therefore the dialling sequence will be terminated when a zero appears.

#### Example

To program the number 9 672 1055 completely, you would program 

9	6	7	2	1	10	5	5	0
---	---	---	---	---	----	---	---	---

.

### Programming A Four Second Pause In The Phone Number

To enter a four second pause in the dialling sequence, you would need to program the value '13'. This may be necessary when the dialler is communicating through an old (slower) telephone exchange or where a PABX system is in place.

#### Example

To program the number 02 pause 9 672 1055, you would program 

10	2	13	9	6	7	2	1	10	5	5	0
----	---	----	---	---	---	---	---	----	---	---	---

.

Digit Required	Number To Program	Digit Required	Number To Program
0	10	8	8
1	1	9	9
2	2	Stop	0
3	3	*	11
4	4	#	12
5	5	Pause (4 sec)	13
6	6	Break	14
7	7		

Table 42: Dialling Digits

### Primary Telephone Number

#### LOCATION 000 - 015

0	0	0	0	0	0	0	0	0	0	0	0	0	0	0	0
---	---	---	---	---	---	---	---	---	---	---	---	---	---	---	---

When the control panel has triggered, the control panel will dial this number in an attempt to contact the monitoring station, pager etc. If the call is successful, the relevant information will be transmitted and the dialler will return back to the stand-by mode.

If unsuccessful, the dialler will try twice more using the "Primary Telephone Number" after which the "Secondary Telephone Number" will be called three times. This procedure will be repeated only once again (ie. Maximum of 12 call attempts per alarm) after ten minutes if none of the first six attempts were successful.

**Note:** When programming the telephone number, if a '0' is required, it must be programmed as a '10'.

Please contact your monitoring station or pager company for the relevant telephone numbers before programming this location.

**Secondary Telephone Number**

**LOCATION 016 - 031**

0 0 0 0 0 0 0 0 0 0 0 0 0 0 0 0 0 0

Refer to the Primary Telephone Number for programming information.

**Callback Telephone Number**

**LOCATION 032 - 047**

0 0 0 0 0 0 0 0 0 0 0 0 0 0 0 0 0 0

This location contains the telephone number that will be called when Upload/Download is requested or the number **6** button is held down to initiate a modem call from the control panel to establish a communications link with the remote computer. The computer must be running the Alarm Link Software (CC816) and will need to be set to "Waiting For An Incoming Call". The "Callback Telephone Number" is also required to be programmed if "Remote Connect With Callback Verification" on page 70 is required.

**Dialling Format**

**LOCATION 048**

**1**

The method for dialling telephone numbers is entered here. Options 3 and 6 will alternate the dialling sequence between DTMF and Decadic if the call to the base station receiver was unsuccessful. Caution should be exercised when selecting the dialling method.

Only use the Australian method if the control panel is to be connected to the Australian Telecommunications Network. The International DTMF dialling option should only be used in those countries that allow both the caller and the receiver to terminate the phone call. Using the incorrect format will disable EDM's patent Telephone Anti-Jamming feature.

<i>Option</i>	<i>Dialling Format</i>	<i>Option</i>	<i>Dialling Format</i>
<b>1</b>	Australian DTMF (Touch Tone)	<b>4</b>	International DTMF (Touch Tone)
<b>2</b>	Australian Decadic	<b>5</b>	Reversed Decadic (10 Minus 1)
<b>3</b>	Alternating DTMF & Australian Decadic	<b>6</b>	Alternating DTMF & Reversed Decadic

*Table 43: Dialling Formats*

**Note:** The alternating sequence is as follows; DTMF - Decadic - DTMF - Decadic - DTMF - Decadic

**Handshake Tone**

**LOCATION 049**

1

This location sets the type of handshake tone required before data transmissions to the monitoring station will begin.

1. Hi Lo Handshake Tone is required when the control panel requires to communicate in Contact ID Format or High Speed DTMF.
2. 1400 Hz Handshake Tone is required when the control panel requires to communicate in Ademco Lo Speed Format, Domestic Dialling Format or Synthesised Voice Formats.
3. 2300 Hz Handshake Tone is required when the control panel needs to communicate in SESCOA Lo Speed Format.
4. No Handshake Tone is not recommended.
5. Pager Handshake is required when the control panel needs to communicate in Basic Pager Format or PET Alpha Pager Format.

Option	Handshake Tone	Option	Handshake Tone
1	HI LO Handshake (Contact ID Format)	4	No Handshake
2	1400 Hz Lo Speed (Ademco Tx At 1900Hz)	5	Pager Handshake
3	2300 Hz Lo Speed (SESCOA Tx At 1800 Hz)		

Table 44: Handshake Tones

**Transmission Format**

**LOCATION 050**

1

Enter the desired transmission format here. This location selects the data format that will be transmitted to the monitoring station receiver. This location also allows you to configure the control panel for domestic, synthesised voice or pager reporting formats.

Option	Transmission Format	Option	Transmission Format
1	Contact ID	9	Reserved
2	4+2 Express	10	Reserved
3	4+2 Pulsed	11	Domestic
4	4+2 Pulsed + Checksum	12	Basic Pager
5	4+1 Pulsed Universal	13	Reserved
6	4+1 Pulsed Expanded	14	Alpha Pager
7	3+1 Pulsed Universal	15	Synthesised Voice
8	3+1 Pulsed Expanded		

Table 45: Transmission Formats

**Transmission Speed****LOCATION 051**

2

This location selects the speed at which data is transmitted to the base station receiver when Low-Speed Pulsed transmission formats are used. Altering this location will only effect pulsed transmission formats.

<b>Option</b>	<b>Transmission Speed</b>	<b>Option</b>	<b>Transmission Speed</b>
<b>1</b>	1 Pulse Per Second	<b>4</b>	20 Pulses Per Second
<b>2</b>	10 Pulses Per Second	<b>5</b>	20 Pulses Per Second Fixed Digit Length
<b>3</b>	15 Pulses Per Second	<b>6</b>	40 Pulses Per Second

**Receivers and Their Formats**

The following is a list of some compatible control room receivers, their specific handshake tones and transmission formats. Use this table only as a guide when selecting the transmission format.

<b>Receiver Type</b>	<b>Transmission Format</b>
Silent Knight Ademco Slow	10 PPS, 1400 Hz HS, 3+1, 3+2, 4+1, 4+2
Sescoa Franklin DCI Vertex	20 PPS, 2300 Hz, 3+1, 3+2, 4+1, 4+2
Silent Knight FAST	20 PPS, 2300 HS, 3+1, 3+2, 4+1, 4+2
Ademco	10 PPS, 1400 Hz HS, 3+1, 3+2, 4+1, 4+2 20 PPS, 2300 Hz HS, 3+1, 3+2, 4+1, 4+2 40 PPS, 1400 Hz HS, 3+1, 3+2, 4+1, 4+2 DTMF, Hi-Low HS, Expanded Format, 4+2 Express
FBI	10 PPS, 1400 Hz HS or 2300 Hz HS, 3+1, 3+2, 4+1, 4+2 20 PPS, 1400 Hz HS or 2300 Hz HS, 3+1, 3+2, 4+1, 4+2 40 PPS, 1400 Hz HS or 2300 Hz HS, 3+1, 3+2, 4+1, 4+2 DTMF, 1400 Hz HS or 2300 Hz or Hi-Low, 4+2 or 4+2+CS DTMF, Hi-Low HS, Expanded Format

**Table 46: Receivers and Their Formats**

If your base station receiver type is not listed above, do not despair, there are many combinations of formats, speeds and handshake tones. Try a few combinations and you will more than likely find the one that works for your receiver.

It should be noted that some formats offer much more detailed information than others, so take the time to consider the many alternatives being offered.

**Subscriber ID Number****LOCATION 052 - 055**

This number is transmitted to identify the calling control panel. Enter the desired Subscriber ID Number in the four locations provided. For Basic Pager Format, "LOCATION 052" is ignored and the first digit of the Subscriber ID Number required must start in "LOCATION 053". When using Domestic Dialling Format, the number of identification beeps will be the number that is programmed in "LOCATION 055". This gives the ability to identify between 15 different control panels calling the same telephone number.

**Ring Count****LOCATION 063**

This location sets the number of rings before the control panel will answer an incoming call. This should be set at an acceptable level bearing in mind that one ring = "Ring, Ring - Ring, Ring" and that a ring count of 10 represents approximately 60 seconds. This location only has an effect if remote arming and/or remote Upload/Download via Alarm Link Software has been enabled. If this location is programmed as 'zero', then the answering of incoming calls will be totally disabled irrespective of any programmed options.

**Answering Machine Bypass**

Answering machine bypass has been incorporated so that it is possible to make a connection with the control panel for remote arming or Upload/Download when there is an answering machine or facsimile machine on the same telephone line. There are two different methods of using answering machine bypass as explained below. The secondary method should only be used when there is a large amount of traffic on the line (eg. A home office). It will reduce the chance of the control panel incorrectly answering incoming calls.

1. Programming the ring count as 15 will enable "Answering Machine Bypass" in the primary mode. When calling the control panel, let the phone ring for no more than 4 rings and then hang up. If you call again within 45 seconds, the control panel will answer the call on the first ring and the connection will be established. This will prevent the answering machine or facsimile from answering the call. Refer to "LOCATION 664" on page 151 if you wish to enable "Answering Machine Bypass Only When System Is Armed".
2. **(From Software Version 1.37 Onwards)**  
Programming a 14 as the ring count will enable "Answering Machine Bypass" in the secondary mode. In this mode, when calling the control panel, allow the phone to ring for no more than 2 rings and then hang up. Wait a minimum of 8 seconds before calling the control panel again. The control panel will now answer on the first ring. If you don't wait the 8 seconds, the control panel will not answer the call. Refer to "LOCATION 664" on page 151 if you wish to enable "Answering Machine Bypass Only When System Is Armed".

---

**Note:** You should set the ring count on the answering machine or facsimile machine to be higher than two rings. Four or six rings would be preferred.

---



# Access Codes

---

## **This Section Includes The Following:**

- *Installer Code*
- *User Codes*
- *User Code Priority*
- *Auxiliary Codes*
- *Code Retries*

# Access Codes

This section describes the access codes that are used to assign privileges and access functions for user code holders of the system. Three types of user codes exist within the system, the Installer Code, User Codes and Auxiliary Codes. Each of these codes allow specific access and operation of the varied functions of the control panel.

## Installer Code

### LOCATION 56 - 62

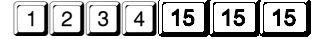

This code is used to access the Installer's Programming Mode and can be between one to seven digits long. However, after the control panel has been powered up, the Installer Code can disarm the system if it is the first code used. The next time the Installer Code is used, access into Installer's Programming Mode will be gained.

## User Codes

### LOCATION 064 - 319

The purpose of user codes is to arm and disarm the system as well as perform other specific functions as described in "Master Code Functions" on page 50.

User codes can be any length between one to seven digits long. Each user code can have a different priority level allocated to it. This controls the behaviour of the code, allowing it to arm only or to arm and disarm etc. This priority level of each user code is programmed in the last location of each user code.

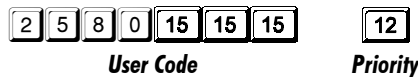

There are a total of 32 user codes available that can be altered or deleted at any time by a Master Code holder. Multiple Master Codes can be programmed. Refer to "Master Code Functions" on page 50 for more information on adding, deleting or changing user codes.

**Note: The priority level for each user code can only be programmed or altered by the installer.**

## User Code Priority

There are seven different priority levels that can be allocated to the user code. Each priority level allows or restricts the functions that different user code holders can perform.

---

**Note:** Once user code priority levels 4, 6 and 12 have been enabled to any of the available 32 user codes, the method of "Standard Isolating" will no longer operate. Only those user codes with the priority level of 4, 6 and 12 will be able to isolate zones using the method "Code To Isolate".

---

Priority Level	Description
0	Arming & Disarming
1	Arming Only
2	Patrolman Code
4	Arming & Disarming + Code To Isolate
6	Patrolman Code + Code To Isolate
8	Master Code Functions
12	Master Code Functions + Code To Isolate

Figure 4: Priority Levels

### 0 Arming & Disarming

This priority level allows the user code holder to arm and disarm the system.

### 1 Arming Only

This priority level allows the user code holder to arm the system but not disarm it.

### 2 Patrolman Code

A Patrolman Code will allow you to issue a code that will only disarm the system after an alarm has occurred. This will prevent unauthorised use of the code. A Patrolman Code can always arm the system. This code is designed to work in conjunction with Open/Close reports to gain maximum benefit. Refer to "LOCATION 664" on page 151 to enable "Open/Close Reports To Be Transmitted Only After An Alarm Has Occurred".

### 4 Arming/Disarming Allowed + Code To Isolate

This priority level allows arming and disarming of the control panel. Isolating of zones will only be allowed by using the method "Code To Isolate" once this priority level has been set. Refer to "Isolating Zones" on page 41 for further information.

### 6 Patrolman Code + Code To Isolate

This priority level allows the Patrolman Code to disarm the system once an alarm has occurred. Isolating zones will only be allowed by using the method "Code To Isolate" once this priority level has been set. A Patrolman Code can always arm the system. Refer to "Isolating Zones" on page 41 for further information.

### 8 Master Code Functions Are Allowed

This priority level allows arming and disarming of the control panel and the ability to carry out any of the Master Code Functions described on page 50. More than one user code can be allocated to this priority level.

### 12 Master Code Functions Are Allowed + Code To Isolate

This priority level allows arming and disarming of the control panel and the ability to carry out any of the Master Code Functions described on page 50. More than one user code can be allocated to this priority level. Isolating zones will only be allowed by using the method "Code To Isolate" once this priority level has been set. Refer to "Isolating Zones" on page 41 for further information.

<b>User Code 3</b> Location 080 - 087 15 15 15 15 15 15 15 0	<b>User Code 1</b> Location 064 - 071 2 5 8 0 15 15 15 8	<b>User Code 2</b> Location 072 - 079 15 15 15 15 15 15 15 0
<b>User Code 6</b> Location 104 - 111 15 15 15 15 15 15 15 0	<b>User Code 4</b> Location 088 - 095 15 15 15 15 15 15 15 0	<b>User Code 5</b> Location 096 - 103 15 15 15 15 15 15 15 0
<b>User Code 9</b> Location 128 - 135 15 15 15 15 15 15 15 0	<b>User Code 7</b> Location 112 - 119 15 15 15 15 15 15 15 0	<b>User Code 8</b> Location 120 - 127 15 15 15 15 15 15 15 0
<b>User Code 12</b> Location 152 - 159 15 15 15 15 15 15 15 0	<b>User Code 10</b> Location 136 - 143 15 15 15 15 15 15 15 0	<b>User Code 11</b> Location 144 - 151 15 15 15 15 15 15 15 0
<b>User Code 15</b> Location 176 - 183 15 15 15 15 15 15 15 0	<b>User Code 13</b> Location 160 - 167 15 15 15 15 15 15 15 0	<b>User Code 14</b> Location 168 - 175 15 15 15 15 15 15 15 0
<b>User Code 18</b> Location 200 - 207 15 15 15 15 15 15 15 0	<b>User Code 16</b> Location 184 - 191 15 15 15 15 15 15 15 0	<b>User Code 17</b> Location 192 - 199 15 15 15 15 15 15 15 0
<b>User Code 21</b> Location 224 - 231 15 15 15 15 15 15 15 0	<b>User Code 19</b> Location 208 - 215 15 15 15 15 15 15 15 0	<b>User Code 20</b> Location 216 - 223 15 15 15 15 15 15 15 0
<b>User Code 24</b> Location 248 - 255 15 15 15 15 15 15 15 0	<b>User Code 22</b> Location 232 - 239 15 15 15 15 15 15 15 0	<b>User Code 23</b> Location 240 - 247 15 15 15 15 15 15 15 0
<b>User Code 27</b> Location 272 - 279 15 15 15 15 15 15 15 0	<b>User Code 25</b> Location 256 - 263 15 15 15 15 15 15 15 0	<b>User Code 26</b> Location 264 - 271 15 15 15 15 15 15 15 0
<b>User Code 30</b> Location 296 - 303 15 15 15 15 15 15 15 0	<b>User Code 28</b> Location 280 - 287 15 15 15 15 15 15 15 0	<b>User Code 29</b> Location 288 - 295 15 15 15 15 15 15 15 0
	<b>User Code 31</b> Location 304 - 311 15 15 15 15 15 15 15 0	<b>User Code 32</b> Location 312 - 319 0 15 15 15 15 15 15 1

**Note: User Codes 16 - 32 report as user 15 except for Contact ID Format.**

User Code 32 also reports when any of the following methods for arming and disarming are used.

1. Arm and disarm via Remote Radio Control equipment connected to the JP5 pins or the optional Radio Key/Keypad Interface (CC813).
2. Arm and disarm the system via Alarm Link Software (CC816).
3. Arm and disarm the system remotely over the telephone.
4. Single button arming in AWAY Mode, STAY Mode 1 or STAY Mode 2.
5. Single button disarming from STAY Mode 1 or STAY Mode 2.
6. Automatic arming in AWAY Mode or STAY Mode 1.

## Auxiliary Codes

Auxiliary Codes can be used to operate programmable outputs. Refer to Output Event Types "2,12" and "2,13" on page 131 for further information.

Auxiliary Codes can be any length from one to seven digits long. Any unused location should be programmed with the value 15.

The priority level (Which is the last location of each Auxiliary Code) controls the behaviour of the code, allowing the code to operate when the system is armed or disarmed etc. Refer to "Table 47: Auxiliary Code Priority Levels" below for the available options.

### Auxiliary Code 1

LOCATION 320 - 327

15 15 15 15 15 15 15 2

### Auxiliary Code 2

LOCATION 328 - 335

15 15 15 15 15 15 15 2

Priority Level	Description
1	Operate When The System Is Armed
2	Operate When The System Is Disarmed
3	Operate When The System Is Armed Or Disarmed
4	Operate Always As Long As No Alarm memories Are Present
5	Operate If Armed & No Alarm Memories Are Present
6	Operate If Disarmed & No Alarm Memories Are Present
7	Operate If Armed Or Disarmed & No Alarm Memories Are Present

Table 47: Auxiliary Code Priority Levels

When the control panel has been partitioned, the Auxiliary Codes are global to all areas. This means that an output that is controlled from an Auxiliary Code can be operated from all areas. Auxiliary Codes cannot be dedicated to an area.

### Code Retries

LOCATION 338

6

Code retries restricts the amount of times an invalid user code can be used in an attempt to operate the system.

This location sets the number of incorrect code attempts that will cause an alarm condition. When the number of incorrect code attempts equals the number programmed in this location, the system will carry out the following;

1. Activate the sirens, internal screamers and strobes connected to the control panel. Refer to "LOCATION 666" on page 153 to enable "Access Denied To Be Silent".
2. Shutdown all codepads (Including "CP5 Area Addressable (CP500A)" codepads and "CP5 Master Partitioned (CP500P)" codepads that are connected to the control panel and lock them out for the time period programmed in "LOCATION 640 - 641" on page 142.
3. Transmit an "Access Denied" (Contact ID Event Code 421) report to the base station receiver. Refer to "LOCATION 484 - 487" on page 118 for more information.

Each time the system is armed or disarmed, the counter is reset. The number of attempts can be anywhere between 1 - 15. If you program a zero into this location, the code attempts are unlimited and neither of the three points listed above will take place. This function works when the system is in the armed or disarmed state.



# Zone Programming

---

## **This Section Includes The Following:**

- *Zone Programming*
- *Zone Operating Information*
- *Zone Reporting Information*
- *Zone Defaults*
- *Zone Options*
- *Zone Pulse Count*
- *Zone Pulse Count Handover*
- *Zone Pulse Count Time*
- *Day Alarm*
- *Day Alarm Resetting*
- *Day Alarm Latching*
- *Day Alarm Operation*
- *Day Alarm In Partitioning*
- *EOL Resistor Value*

# Zone Programming

Each zone contains eight locations that are divided into two groups of four. The first four locations determine how the zone operates, while the second four locations contain the dialler reporting information.

## Zone Operating Information

- Zone Type** This location programs the “Zone Type” required (eg. Delay-1, Instant, 24 Hour etc).
- Zone Option** This location controls the zone (eg. Lockout Siren, Silent etc).
- Zone Pulse Count** This location sets how many times the zone must trigger within the time specified in the “Zone Pulse Count Time”.
- Zone Pulse Count Time** This parameter sets the time period for the number of times the zone must trigger before activating an alarm.

## Zone Reporting Information

- Hundreds Digit** The hundreds digit of the Contact ID Event Code is programmed into this location. This location is also the “Alarm Restore” code in all other reporting formats. Refer to Event Codes on Page 73
- Tens Digit** The tens digit of the Contact ID Event Code is programmed into this location. This location is the “Alarm” code in all other reporting formats. Refer to Event Codes on Page 73
- Units Digit** The units digit of the Contact ID Event Code is programmed into this location. This location is the “Channel” code that the zone reports on in other reporting formats other than Contact ID Format. Refer to Event Codes on Page 73
- Dialler Channel** This location is factory default to report on dialler channel 1. If the system has been partitioned, zones allocated to report on areas other than Area 1 should have their dialler channel correspond to the area number that the zone is allocated to. Refer to Event Codes on Page 73



## Zone Defaults

<b>Zone 1</b> Location 340 - 347	<b>Zone 2</b> Location 348 - 355
2 0 0 0 1 3 0 1	1 0 0 0 1 3 0 1
<b>Zone 3</b> Location 356 - 363	<b>Zone 4</b> Location 364 - 371
1 0 0 0 1 3 0 1	1 0 0 0 1 3 0 1
<b>Zone 6</b> Location 380 - 387	<b>Zone 7</b> Location 388 - 395
0 0 0 0 1 3 0 1	0 0 0 0 1 3 0 1
<b>Zone 9</b> Location 404 - 411	<b>Zone 10</b> Location 412 - 419
0 0 0 0 1 3 0 1	0 0 0 0 1 3 0 1
<b>Zone 12</b> Location 428 - 435	<b>Zone 13</b> Location 436 - 443
0 0 0 0 1 3 0 1	0 0 0 0 1 3 0 1
<b>Zone 15</b> Location 452 - 459	<b>Zone 16</b> Location 460 - 467
0 0 0 0 1 3 0 1	0 0 0 0 1 3 0 1
<b>Zone 5</b> Location 372 - 379	<b>Zone 8</b> Location 396 - 403
1 0 0 0 1 3 0 1	12 0 0 0 1 3 3 1
<b>Zone 11</b> Location 420 - 427	<b>Zone 14</b> Location 444 - 451
0 0 0 0 1 3 0 1	0 0 0 0 1 3 0 1



## Zone Types

There are sixteen different zone types to choose from. Each zone has the ability to be programmed as any one of the types listed below;

<b>Zone Type</b>	<b>Description</b>	<b>Zone Type</b>	<b>Description</b>
<b>0</b>	Instant	<b>8</b>	Delay-1 + Isolated In STAY Mode 1
<b>1</b>	Handover	<b>9</b>	Delay-2 + Isolated In STAY Mode 1
<b>2</b>	Delay-1	<b>10</b>	Delay-3 + Isolated In STAY Mode 1
<b>3</b>	Delay-2	<b>11</b>	Delay-4 + Isolated In STAY Mode 1
<b>4</b>	Delay-3	<b>12</b>	24 Hour Burglary
<b>5</b>	Delay-4	<b>13</b>	24 Hour Fire
<b>6</b>	Instant + Isolated In STAY Mode 1	<b>14</b>	Chime Only
<b>7</b>	Handover + Isolated In STAY Mode 1	<b>15</b>	Zone Not Used

*Table 48: Zone Types*

### **0 Instant Zone**

An Instant zone will sound the sirens and operate the dialler as soon as it registers as unsealed after the exit time has expired.

### **1 Handover Zone**

A Handover zone will act as an instant zone if it has been triggered by itself. If a handover zone is triggered after a delay zone, the remaining delay time will handover from the delay zone to the handover zone. Handover may be sequential or random. Refer to Option 2 in "LOCATION 666" on page 153 if you require handover to be sequential or non sequential.

### **2 Delay-1 Zone**

A Delay-1 zone will have a delay time determined by the value in "Entry Timer 1" on page 140.

### **3 Delay-2 Zone**

A Delay-2 zone will have a delay time determined by the value in "Entry Timer 2" on page 140.

### **4 Delay-3 Zone**

A Delay-3 zone will have a delay time determined by the value in "Entry Timer 3" on page 140.

### **5 Delay-4 Zone**

A Delay-4 zone will have a delay time determined by the value in "Entry Timer 4" on page 140.

### **6 Instant Zone + Isolated In STAY Mode 1**

This zone will act as an Instant zone when the system is armed in the AWAY Mode, but will be automatically isolated when the system is armed in STAY Mode 1.

### **7 Handover Zone + Isolated In STAY Mode 1**

This zone will act as a Handover zone when the system is armed in the AWAY Mode, but will be automatically isolated when the system is armed in STAY Mode 1.

### **8 Delay-1 Zone + Isolated In STAY Mode 1**

This zone will act as a Delay-1 zone when the system is armed in the AWAY Mode, but will be automatically isolated when the system is armed in STAY Mode 1.

## **9 Delay-2 Zone + Isolated In STAY Mode 1**

This zone will act as a Delay-2 zone when the system is armed in the AWAY Mode, but will be automatically isolated when the system is armed in STAY Mode 1.

## **10 Delay-3 Zone + Isolated In STAY Mode 1**

This zone will act as a Delay-3 zone when the system is armed in the AWAY Mode, but will be automatically isolated when the system is armed in STAY Mode 1.

## **11 Delay-4 Zone + Isolated In STAY Mode 1**

This zone will act as a Delay-4 zone when the system is armed in the AWAY Mode, but will be automatically isolated when the system is armed in STAY Mode 1.

## **12 24 Hour Burglary Zone**

24 Hour Burglary zone is always ready to trigger the horn speaker, bell and strobe regardless of whether the system is in the armed or disarmed state.

## **13 24 Hour Fire Zone**

A 24 Hour Fire zone is always ready to trigger the horn speaker, bell and strobe regardless of whether the system is in the armed or disarmed state. A distinct fire sound is emitted through the horn speaker to indicate this type of alarm condition. This fire sound is completely different to the burglary sound.

## **14 Chime Zone (Follow Me)**

A Chime zone is not a burglary zone. It can never sound the sirens or trigger the dialler. Its purpose is to map it to a programmable output for an indication of sealed or unsealed. Refer to Output Event Type "4,5" on page 132.

Chime zones require EOL resistors and they will register at a remote codepad. These zones do not effect the operation of forced arming.

## **15 Zone Not Used**

If a zone is not used, program it as a zone type of 15. This zone will never sound the sirens or trigger the dialler. An EOL resistor is not required if this zone type is used.

## Zone Options

Option	Description
1	Lockout Siren
2	Lockout Dialler
4	Silent Alarm
8	Sensor Watch

Table 49: Zone Options

### 1&2 Lockout Siren & Lockout Dialler

Lockout means one activation per arming cycle (ie. A zone programmed for "Lockout" can only cause the sirens or dialler to operate once).

When the system is next armed, the zone can cause the sirens and dialler to operate once more. As can be seen by "Table 49: Zone Options", the sirens can be locked out but still leave the dialler to transmit all reports to the base station receiver by programming "Zone Option 1". Programming "Zone Option 2" will lockout the dialler but leave the sirens to be reset. Programming "Zone Option 3" (ie. 1+2=3), will lockout both the sirens and dialler. Restore signals will be transmitted when the system has been disarmed.

The *Solution-16* control panel performs lockout different to most other control panels in that only the first zone to trigger an alarm condition will be locked out. All other zones that are triggered during the same siren run time will reset when the sirens reset. This prevents an intruder from triggering all zones then waiting for the sirens to stop before re-entering the premises.

#### Example

All zones are programmed for both lockout siren and dialler. Zone 1 is triggered followed by all other zones causing the sirens to sound and the dialler to report to the base station receiver. Zone 1 will be the only zone that stops reporting to the base station receiver because of the first zone to trigger is locked out. The remaining zones will continue to report if they are triggered again.

#### (Solution-16 With Software Version 1.10 - 1.37)

For *Solution-16* control panels with software version 1.10 - 1.37, refer to "Swinger Shutdown Count" in "LOCATION 662" on page 146 to set the number of times the siren and/or dialler will activate before lockout will take effect.

#### (Solution-16 With Software Version 1.40 Onwards)

For *Solution-16* control panels with software version 1.40, refer to "LOCATION 662" on page 147 to set the number of times the siren will be allowed to activate before it will be locked out and "LOCATION 757" on page 147 to set the number of times the dialler will activate before lockout will take effect.

### 4 Silent Alarm

A zone programmed to be silent will not trigger the HORN SPEAKER, RELAY, STROBE or EDMSAT outputs. The dialler and all other programmable outputs will function as per their particular programming.

## 8 Sensor Watch

Sensor watch gives the control panel the ability to recognise that detection devices may have stopped working. This is a feature that monitors the operation of a zone over a programmed time period. Refer to "LOCATION 642 - 643" on page 142 for programming "Sensor Watch Time".

This value determines how many 24 hour periods a zone may remain continuously sealed before it registers as a "Sensor Watch" fault. The number of hours required to fulfil these 24 hour periods is only calculated while the system is in the disarmed state. Every time the system is armed the counter pauses calculating. Sensor watch will continue calculating the next time the system has been disarmed.

### Example

If the "Sensor Watch Time" is programmed for two days in a situation where a premises is armed for twelve hours and disarmed for twelve hours each day, it will take four days before a zone can register as a faulty sensor watch zone.

## Zone Pulse Count

Zone pulse count is the number of times a zone must be triggered before the zone registers as an alarm. The number of pulses vary between 0 - 15. The zone pulse count value is relative to a time frame (ie. The number of pulses must be present during a particular time frame). Refer to "Table 51: Zone Pulse Count Times" on page 109 for time frame settings.

Option	Number Of Pulses	Option	Number Of Pulses
0	None	8	8
1	1	9	9
2	2	10	10
3	3	11	11
4	4	12	12
5	5	13	13
6	6	14	14
7	7	15	15

Table 50: Number Of Pulses

Zone pulse count does not effect the LED indicators on a codepad. The triggering of a zone will always illuminate the respective indicator but an alarm condition will not occur until the total number of pulses has been reached.

A zone programmed as a day alarm zone is not effected by any pulse count setting (ie. Pulse count is only relevant when the system is in the armed state).

---

**Note:** A pulse count of zero disables both the zone pulse count and zone pulse count time. The zone will cause an alarm as soon as it becomes unsealed. The loop response time in this instance defaults to 150 ms.

---

## Zone Pulse Count Handover

Zone pulse count handover will only operate with zone pulse count time options 8 - 15. Refer to "Zone Pulse Count Time" on page 109 for more information.

Any zone that registers one trigger pulse will automatically increment any other zones pulse count that has already registered at least one trigger pulse during its respective time. To enable this option refer to "LOCATION 667" on page 154 for further details.

---

**Note:** From Software Version 1.37 onwards, 24 hour zones do not receive any handover pulses from other zones. 24 hour zones may handover pulses to other zones.

---

## Zone Pulse Count Time

Zone pulse count time is the time frame or period over which the programmed number of pulses must register before an alarm condition is generated.

<b>20 ms Loop Response Time</b>		<b>150 ms Loop Response Time</b>	
<b>Option</b>	<b>Pulse Count Time</b>	<b>Option</b>	<b>Pulse Count Time</b>
<b>0</b>	0.5 Seconds	<b>8</b>	20 Seconds
<b>1</b>	1 Second	<b>9</b>	30 Seconds
<b>2</b>	2 Seconds	<b>10</b>	40 Seconds
<b>3</b>	3 Seconds	<b>11</b>	50 Seconds
<b>4</b>	4 Seconds	<b>12</b>	60 Seconds
<b>5</b>	5 Seconds	<b>13</b>	90 Seconds
<b>6</b>	10 Seconds	<b>14</b>	120 Seconds
<b>7</b>	15 Seconds	<b>15</b>	200 Seconds

*Table 51: Zone Pulse Count Times*

For zone pulse count time, options 0 - 7 have a zone loop response time of 20 ms. For zone pulse count time, options 8 - 15 have a zone loop response time of 150 ms. Loop response time is the length of time a zone must be triggered before it can register as unsealed or as a valid pulse.

Inertia sensors should use options 0 - 7, while PIR detectors should use options 8 - 15.

---

**Note:** Zones which trigger for more than 10 seconds continuously will be considered unsealed and cause an alarm condition irrespective of any zone pulse count or zone time settings

---

## LOCATION 336

1

Option	Day Alarm Zone
1	Zone 1
2	Zone 2
4	Zone 3
8	Zone 4

Table 52: Day Alarm Zones 1-4

## LOCATION 337

0

Option	Day Alarm Zone
1	Zone 5
2	Zone 6
4	Zone 7
8	Zone 8

Table 53: Day Alarm Zones 5-8

Day alarm enables a combination of zones to be monitored while the system is in the disarmed state. Indications are available via any of the programmable outputs including the codepad buzzer. This function has been expanded to accommodate latching and non latching day alarm output event types. Refer to Output Event Types "0,14" and "0,15" on page 128 for further information on programming an output for monitoring day alarm zones.

When the system has been armed in the AWAY Mode or STAY Mode 1/STAY Mode 2, zones that have been programmed as day alarm zones will activate the sirens and dialler just as non day alarm zones do. When day alarm has been activated, it will ignore any zone pulse count settings that have been programmed for that zone (ie. Zone pulse count is only relevant when the system has been armed).

### Day Alarm Resetting

An output that is programmed as "Day Alarm Resetting" will operate when a zone programmed for day alarm has been triggered. The output will reset when the zone has returned to normal. This will only occur when the system is disarmed.

### Day Alarm Latching

An output that is programmed as "Day Alarm Latching" will operate when a zone programmed for day alarm has been triggered. The ZONE indicator and the latching output will reset when the **AWAY** button has been pressed. This will only occur when the system is disarmed. Refer to "Output Event Type - 0,15" on page 128 for more information.

If the codepad buzzer has been programmed to operate when a day alarm zone has triggered, all relevant zone indicators will flash while the codepad beeps once a second until the **AWAY** button is pressed.

## **Day Alarm Operation - (Software Version 1.10)**

### **How To Turn Day Alarm ON**

1. Enter your **MASTER CODE** followed by **7** and the **AWAY** button.  
Three beeps will be heard.

### **How To Turn Day Alarm OFF**

1. Enter your **MASTER CODE** followed by **7** and the **AWAY** button.  
Two beeps will be heard.

## **Day Alarm Operation - (Software Version 1.20 Onwards)**

### **How To Turn Day Alarm ON**

1. Hold down the **4** button until three beeps are heard.

### **How To Turn Day Alarm OFF**

1. Hold down the **4** button until two beeps are heard.

If a zone has been programmed for day alarm, the zone can be isolated in the normal way so that it does not register as a day alarm zone. Only zones 1 - 8 can be used as day alarm zones.

The STAY indicator can be programmed to indicate whether day alarm has been turned "On" or "Off". When day alarm has been turned "On", the STAY indicator will flash every three seconds. Refer to "LOCATION 669" on page 158 to enable this option.

Monitoring of zones 9 - 16 can be achieved by programming an output to mimic a zone. Refer to Output Event Types on page 127 for further information.

## **Day Alarm In Partitioning**

Day alarm operates independently for each area when the system has been partitioned. Any area can turn day alarm "On" or "Off" without effecting another area.

**EOL Resistor Value****LOCATION 339**

4

<b>Option</b>	<b>Resistor Value</b>	<b>Option</b>	<b>Resistor Value</b>
<b>1</b>	1K (Brown, Black, Red)	<b>9</b>	10K (Brown, Black, Orange)
<b>2</b>	1K5 (Brown, Green, Red)	<b>10</b>	12K (Brown, Red, Orange)
<b>3</b>	2K2 (Red, Red, Red)	<b>11</b>	22K (Red, Red, Orange)
<b>4</b>	3K3 (Orange, Orange, Black, Brown) 1%	<b>12</b>	Reserved
<b>5</b>	3K9 (Orange, White, Red)	<b>13</b>	Reserved
<b>6</b>	4K7 (Yellow, Violet, Red)	<b>14</b>	Reserved
<b>7</b>	5K6 (Green, Blue, Red)	<b>15</b>	3K3 + 6K8 (Split EOL For 16 Zones)
<b>8</b>	6K8 (Blue, Grey, Black, Brown) 1%		

*Table 54: EOL Resistor Values*

The control panel has the ability to be programmed for different values of EOL resistors. This feature is only applicable to zones one through to eight. This is a global parameter and will effect all eight zones simultaneously. It gives the ability to fit the *Solution-16* control panel into an existing installation without having to change the EOL resistors. This feature also increases the security of the system as there are eleven possible EOL resistor values that can be used. This makes it extremely difficult for anyone to tamper with the system.

The EOL resistor value for the zones can be chosen from any of the different values listed. If 16 zones are required, an EDM Zone Expansion Board will be required to be fitted to the control panel and enabled in "LOCATION 672" on page 161.

If split EOL resistors have been selected, the control panel will look for sixteen EOL resistors consisting of 3K3 resistors for zones 1 - 8 and 6K8 resistors connected in parallel for zones 9 - 16. The zone 1 termination on the PCB becomes the termination for zones 1 and 9.

---

**Note:** Caution should be exercised when using split EOL resistors to create 16 zones. This configuration is only suitable for normally closed contacts. If normally open contacts are used, as is the case with most types of smoke detectors, a short circuit on one zone will trigger both zones connected in parallel.

---

If there is a requirement to use a normally open contact with split EOL, program either the primary or secondary zone as not used.

If split EOL resistors are not suitable, there is a choice of two eight zone expansion boards that can be purchased and fitted to the control panel. The Eight Zone Expansion Board (CC883) can be programmed for different resistor values, whereas the Eight Zone Expansion Board (CC885) is fixed for 3K3 EOL resistors. These eight zone expansion boards provide additional terminations for zones 9 - 16. Refer to "LOCATION 672" on page 161 to enable the expansion board fitted.



# System Status Information

---

## **This Section Includes The Following:**

- *Bypass Codes For Zones 1-8*
- *Bypass Codes For Zones 9-16*
- *Trouble Codes For Zones 1-8*
- *Trouble Codes For Zones 9-16*
- *Codepad Duress*
- *Codepad Panic*
- *Access Denied*
- *AC Fail*
- *Low Battery*
- *Program Altered Code*
- *Sensor Watch*
- *Safecom RF Fail*
- *Safecom Telco Fail*
- *Safecom RF Jamming*
- *Open/Close Codes*
- *Test Reports*

## System Status Information

This section covers features that are involved with the basic house keeping of the system. This includes monitoring of the zones - whether they are isolated from the system or more importantly that they are actually operating, the status of both the AC mains and DC power to the system and codepad generated alarms activated by the user.

### Bypass Codes For Zones 1-8

#### LOCATION 468 - 469



<i>Location</i>	<i>Description</i>
468	Alarm Or Expansion Code In 4+2 Format
469	Restore Code In 4+2 Format

*Table 55: Zone Bypass Codes For Zones 1-8*

A zone is bypassed when it is manually isolated. A "Zone Bypass" report (Contact ID Event Code 570) will be transmitted at the end of exit time for zones that have been manually isolated. 24 hour zones cannot be manually isolated, therefore they will never transmit bypass reports.

A "Zone Bypass Restore" report will be transmitted when the system has been disarmed. If bypass restore is not programmed, it can be assumed that it will transmit a bypass restore report when an opening report is transmitted. All bypassed zones are automatically cleared when the system has been disarmed.

The bypass code parameter is used as the expansion digit in 4+2 Formats. It has no effect on Contact ID Format as a zone bypass will always be reported on event code 570.

A "Zone Bypass" report will be transmitted on which ever dialler channel the respective zone has been allocated to when the system has been partitioned.

**Note:** If "Zone Bypass" reports are not required, program "LOCATION 468 - 471" with a zero.

### Bypass Codes For Zones 9-16

#### LOCATION 470 - 471



<i>Location</i>	<i>Description</i>
470	Alarm Or Expansion Code In 4+2 Format
471	Restore Code In 4+2 Format

*Table 56: Zone Bypass Codes For Zones 9-16*

Refer to "Bypass Codes For Zones 1-8" for more information.

**Trouble Codes For Zones 1-8****LOCATION 472 - 473**

<i>Location</i>	<i>Description</i>
472	Alarm Or Expansion Code In 4+2 Format
473	Restore Code In 4+2 Format

*Table 57: Zone Trouble Codes For Zones 1-8*

A zone is in trouble when it is unsealed at the end of exit time. A "Sensor Trouble" report (Contact ID Event Code 380) will be transmitted to indicate that one or more zones have been automatically isolated by the system. 24 hour zones that are unsealed at the end of exit time will not transmit a "Sensor Trouble" report as the restore for that zone is still outstanding.

A "Sensor Trouble" restore report will be transmitted for burglary zones when the zone reseals or when the system is next disarmed (which ever happens first). A 24 hour zone will only transmit a restore signal when it has resealed.

The trouble code parameter is used as the expansion digit in 4+2 Format. It has no effect on Contact ID Format as a "Sensor Trouble" report will always be reported on event code 380.

A "Sensor Trouble" report will be transmitted on which ever dialler channel the respective zone has been allocated to when the control panel has been partitioned.

**Note:** If "Sensor Trouble" reports are not required, program "LOCATION 472-475" with a zero.

"Zone Trouble" and "Zone Trouble Restore" reports will not be transmitted via securitel for software version 1.10 and software version 1.20

**Trouble Codes For Zones 9-16****LOCATION 474 - 475**

<i>Location</i>	<i>Description</i>
474	Alarm Or Expansion Code In 4+2 Format
475	Restore Code In 4+2 Format



*Table 58: Zone Trouble Codes For Zones 9-16*

Refer to "Trouble Codes For Zones 1-8" for more information.

**Codepad Duress****LOCATION 476 - 479**

<b>Location</b>	<b>Description</b>
476	Contact ID Event Code - Hundreds Digit
477	Contact ID Event Code - Tens Digit Or Alarm Or Expansion Digit In 4+2 Format
478	Contact ID Event Code - Units Digit Or Channel Location For All Other Formats
479	Dialler Channel (Dialler Channel 1, 2, 3 or 4)

*Table 59: Codepad Duress Locations*

A "Duress" report (Contact ID Event Code 121) will be transmitted to the base station receiver when the  button is added to the end of any valid user code being used to disarm the system. This alarm will always be silent. A duress alarm can be triggered during exit time (ie. If the system has been armed and then disarmed by adding the  button to the end of the user code before exit time has expired, a "Duress" report will be transmitted. Adding  to the end of a user code when arming the system will not cause a duress alarm.

---

**Note:** Restore signals are not transmitted for this event. If a "Duress" report is not required, program the dialler channel "LOCATION 479" with a zero.

---

**LOCATION 480 - 483**

<b>Location</b>	<b>Description</b>
<b>480</b>	Contact ID Event Code - Hundreds Digit
<b>481</b>	Contact ID Event Code - Tens Digit Or Alarm Or Expansion Digit In 4+2 Format
<b>482</b>	Contact ID Event Code - Units Digit Or Channel Location For All Other Formats
<b>483</b>	Dialler Channel (Dialler Channel 1, 2, 3 or 4)

*Table 60: Codepad Panic Locations*

**Software Version 1.10 - 1.36**

A "Panic Alarm" report (Contact ID Event Code 120) will be transmitted to the base station receiver when any two outside buttons in the same horizontal row on a codepad are pressed simultaneously. This is an audible alarm. Refer to "LOCATION 666" on page 153 if you require codepad panic to be silent.





If Installer's Programming Mode has been entered and a codepad panic alarm has been triggered, the Installer's Programming Mode will be terminated as the panic alarm has priority.



---



**Note:** Restore signals are not transmitted for this event. If a "Panic Alarm" report is not required, program the dialler channel "LOCATION 483" with a zero.

---

**Software Version 1.37 Onwards**

A "Panic Alarm" report (Contact ID Event Code 120) will be transmitted to the base station receiver when either the two outside buttons  and  or  and  are pressed simultaneously. This is an audible alarm. Refer to "LOCATION 666" on page 153 if you require codepad panic to be silent.

A "Fire Alarm" report (Contact ID Event Code 110) will be transmitted to the base station receiver when the  and  buttons are pressed simultaneously. This is an audible alarm.

A "Medical" report (Contact ID Event Code 100) will be transmitted to the base station receiver when the  and  buttons are pressed simultaneously. This is an audible alarm.

---

**Note:** To disable both the reporting and the audible alarms for ALL codepad alarm events, the dialler channel for "Codepad Panic" in "LOCATION 483" will need to be programmed as zero and enable "Enable Codepad Panic To Be Silent" in "LOCATION 666" on page 153.

---

**Access Denied****LOCATION 484 - 487**

4 2 1 1

<i>Location</i>	<i>Description</i>
484	Contact ID Event Code - Hundreds Digit
485	Contact ID Event Code - Tens Digit Or Alarm Or Expansion Digit In 4+2 Format
486	Contact ID Event Code - Units Digit Or Channel Location For All Other Formats
487	Dialler Channel (Dialler Channel 1, 2, 3 or 4)

*Table 61: Access Denied Locations*

An "Access Denied" report (Contact ID Event Code 421) will be transmitted to the base station receiver when the number of incorrect code attempts equals the number programmed in "LOCATION 338" on page 101. This is an audible alarm. Refer to Option 8 in "LOCATION 666" on page 153 if you require this alarm to be silent.

**Note:** Restore signals for this event are not transmitted. If an "Access Denied" report is not required, program the dialler channel "LOCATION 487" with a zero.

**AC Fail****LOCATION 488 - 491**

3 0 1 1

<i>Location</i>	<i>Description</i>
488	Contact ID Event Code - Hundreds Digit
489	Contact ID Event Code - Tens Digit Or Alarm Or Expansion Digit In 4+2 Format
490	Contact ID Event Code - Units Digit Or Channel Location For All Other Formats
491	Dialler Channel (Dialler Channel 1, 2, 3 or 4)

*Table 62: AC Fail Locations*

An "AC Loss" report (Contact ID Event Code 301) will be transmitted to the base station receiver when the AC mains supply has been disconnected for two minutes. If you require an "AC Loss" report to be transmitted to the base station receiver when the AC mains supply has been disconnected for 1 hour, enable Option 4 in "LOCATION 667" on page 154.

A restore signal will be transmitted when the AC mains has been reconnected for two minutes. If you wish to ignore AC fail, enable Option 4 in "LOCATION 668" on page 156.

**Note:** If an "AC Loss" report is not required, program the dialler channel in "LOCATION 491" with a zero.

**Low Battery****LOCATION 492 - 495**

3 0 9 1

<b>Location</b>	<b>Description</b>
492	Contact ID Event Code - Hundreds Digit
493	Contact ID Event Code - Tens Digit Or Alarm Or Expansion Digit In 4+2 Format
494	Contact ID Event Code - Units Digit Or Channel Location For All Other Formats
495	Dialler Channel (Dialler Channel 1, 2, 3 or 4)

*Table 63: Low Battery Locations*

A "Battery Test Failure" report (Contact ID Event Code 309) will be transmitted to the base station receiver when the systems battery voltage falls below 10.5 volts or when a dynamic battery test detects a low capacity battery.

The control panel continually monitors the battery voltage. Refer to "Fault Descriptions" on page 42. A dynamic battery test is performed every time the system (or an area) has been armed as well as every four hours from power up of the control panel.

A "Low Battery Restore" signal will be transmitted if the back up battery has been restored the next time the system is armed, or when the dynamic battery test reports the battery test is OK.

---

**Note:** If a "Battery Test Failure" report is not required, program the dialler channel "LOCATION 495" with a zero.

---

**Program Altered Code****LOCATION 496 - 499**

3 0 6 0

<b>Location</b>	<b>Description</b>
496	Contact ID Event Code - Hundreds Digit
497	Contact ID Event Code - Tens Digit Or Alarm Or Expansion Digit In 4+2 Format
498	Contact ID Event Code - Units Digit Or Channel Location For All Other Formats
499	Dialler Channel (Dialler Channel 1, 2, 3 or 4)

*Table 64: Program Altered Code*

A "Panel Program Altered" report (Contact ID Event Code 306) will be transmitted to the base station receiver when data in one or more locations has been altered in the Installer's Programming Mode.

The transmission will report once Installer's Programming Mode has been terminated. Changes made via the Master Code functions do not cause the "Panel Program Altered" report to be transmitted.

---

**Note:** Restore signals are not transmitted for this event. If a "Panel Program Altered" report is not required, program the dialler channel in "LOCATION 499" with a zero.

---

**Sensor Watch****LOCATION 500 - 503**

3 0 7 1

<b>Location</b>	<b>Description</b>
<b>500</b>	Contact ID Event Code - Hundreds Digit
<b>501</b>	Contact ID Event Code - Tens Digit Or Alarm Or Expansion Digit In 4+2 Format
<b>502</b>	Contact ID Event Code - Units Digit Or Channel Location For All Other Formats
<b>503</b>	Dialler Channel (Dialler Channel 1, 2, 3 or 4)

*Table 65: Sensor Watch Code*

A "Self Test Failure" report (Contact ID Event Code 307) will be transmitted to the base station receiver when a zone has not been triggered during the "Sensor Watch Time" in "LOCATION 642 - 643" on page 142. This report will continue to be transmitted (according to the frequency of the sensor watch time) until the fault has been rectified.

**Note:** Software Version 1.10 - 1.31 transmitted "Sensor Trouble" as Contact ID Event Code 383. From Software Version 1.32, the Contact ID Event Code was changed to 307 - "Self Test Failure".

To clear the fault and stop any further reporting, the zone that registered the fault must be unsealed and resealed again. Refer to "LOCATION 642 - 643" on page 142 to set the number of days a zone may remain sealed before registering as a fault. Refer to "Zone Options" on page 107 to enable a zone to be monitored by the sensor watch feature.

**Note:** Restore signals are not transmitted for this event. If a "Self Test Failure" report is not required, program the dialler channel "LOCATION 503" with a zero.

**Open/Close Codes****LOCATION 504 - 505**

8 9

<b>Location</b>	<b>Description</b>
<b>504</b>	Opening Report Code
<b>505</b>	Closing Report Code

*Table 66: Open/Close Locations*

An "Opening" report (Contact ID Event Code 401) will be transmitted to the base station receiver when the system has been disarmed from AWAY Mode. A "Closing" report (Contact ID Event Code 401) is transmitted at the end of exit time when the system has been armed in the AWAY Mode.

If an expanded format has been selected, this code will be used as the expansion code and the user number that armed or disarmed the system will follow in the same transmission.

Refer to "LOCATION 664" on page 151 for enabling "Open/Close" reports in STAY Mode. To enable "Open/Close" reports only after a previous alarm, refer to "LOCATION 664" on page 151.

**Note:** If you do not require "Open/Close" reports, program "LOCATION 504 - 505" with zero.



**Safecom RF Fail****LOCATION 760 - 763**

(Safecom Only)

3 5 3 1

<b>Location</b>	<b>Description</b>
760	Contact ID Event Code - Hundreds Digit
761	Contact ID Event Code - Tens Digit Or Alarm Or Expansion Digit In 4+2 Format
762	Contact ID Event Code - Units Digit Or Channel Location For All Other Formats
763	Dialler Channel (Dialler Channel 1, 2, 3 or 4) (Point ID =48 Decimal)

An “RF Fail” report (Contact ID Event Code 353) will be transmitted to the base station when the safecom unit misses a poll or fails contact with the base station Receiver. A restore signal will be transmitted when radio communication is restored

**Safecom Telco Fail****LOCATION 764 - 767**

(Safecom Only)

3 5 1 1

<b>Location</b>	<b>Description</b>
764	Contact ID Event Code – Hundreds Digit
765	Contact ID Event Code - Tens Digit Or Alarm Or Expansion Digit In 4+2 Format
766	Contact ID Event Code - Units Digit Or Channel Location For All Other Formats
767	Dialler Channel (Dialler Channel 1, 2, 3 or 4) (Point ID =49 Decimal)

Telco Fail report (Contact ID Event Code 351) will be transmitted via the Safecom network when the telephone line is disconnected. This will only be reported if you are using a Telephone Line Fault Module (CC887) with Location 673 programmed with a 7.

**Safecom RF Jamming****LOCATION 768 - 771**

(Safecom Only)

3 4 4 1

<b>Location</b>	<b>Description</b>
768	Contact ID Event Code – Hundreds Digit
769	Contact ID Event Code - Tens Digit Or Alarm Or Expansion Digit In 4+2 Format
770	Contact ID Event Code - Units Digit Or Channel Location For All Other Formats
771	Dialler Channel (Dialler Channel 1, 2, 3 or 4) (Point ID = 50)

RF Jamming report (Contact ID Event Code 344) will be transmitted when the safecom interface detects carrier for more than the specified period which is determined by the RF Jamming Delay feature in location 772.

**Test Reports**

LOCATION 506 - 513

00000090

<b>Location</b>	<b>Description</b>
506	Actual Required Hour Of The Day (Tens Digit)
507	Actual Required Hour Of The Day (Units Digit)
508	Actual Required Minute Of The Day (Tens Digit)
509	Actual Required Minute Of The Day (Units Digit)
510	Repeat Interval In Days (Tens Digit)
511	Repeat Interval In Days (Units Digit)
512	Expansion Code For 4+2 Format
513	Test Report Options

*Table 67: Test Report Locations*

A "Test" report (Contact ID Event Code 602) is a specific signal that is transmitted to the base station receiver and is normally used to test the dialling and reporting functions of the control panel. Test reports will not be transmitted if the Subscriber ID Number is 0000.

When programming test reports, the control panel needs to know the hour and minute of the day the report is required as well as how often to transmit the report. Test reports are transmitted on a daily basis ranging from every day to every ninety nine days. Refer to "Installer Code Functions" on page 46 to set the first test report.

---

**Note:** If you do not require "Test" reports, program the repeat interval in "LOCATIONS 510-511" as zero.

---

**Test Report Options**

<b>Option</b>	<b>Description</b>
1	Send Test Reports Only If The System Is Armed
2	Send Test Reports On All Active Diallers - Partitioning Only

*Table 68: Test Report Options***1 Send Test Reports Only If The System Is Armed**

If this option has been enabled, test reports will only be transmitted when the system has been armed in the AWAY Mode or STAY Mode 1/STAY Mode 2. It is no longer necessary to send a test report as well as an opening and closing report every day.

During the working week most commercial premises would be open and therefore a test report is not necessary as "Open" and "Close" reports would have been transmitted. On the weekend however, the control panel would be armed and thus test reports would be sent at the programmed time.

**2 Send Test Reports On All Active Diallers - Partitioned Systems Only**

This location enables a "Test" report to be transmitted to the base station receiver for each of the Subscriber ID Numbers that have been programmed when the control panel has been partitioned.

# Programmable Outputs

---

## **This Section Includes The Following:**

- *Programmable Outputs*
- *Redirecting Outputs To The Codepad Buzzer*
- *Output Configurations*
- *Output Polarity*
- *Timing*
- *Pulsing Polarities*
- *One Shot Polarities*

## Programmable Outputs

The *Solution-16* control panel has six fully programmable outputs on the main PCB and an option of adding an extra eight outputs via the 8 Channel Output Expansion Board (CC884). The 8 Channel Output Expansion Board connects onto the pins marked JP5 and JP6 on the control panel and must be enabled in "LOCATION 672" on page 161. Programmable outputs require four parameters to be programmed in order to operate correctly.

<b>Event Type</b>	When To Operate
<b>Polarity</b>	How To Operate
<b>Time Base</b>	How Long To Operate For
<b>Time Multiplier</b>	How Often To Operate

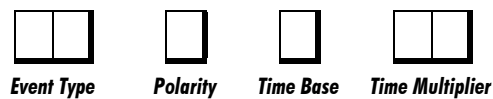

<b>When To Operate</b>	Is selected from the Output Event Types listed on page 127. Each digit should be entered into the two corresponding locations for the output event type required.
<b>How To Operate</b>	Is selected from the "Table 70: Event Type Polarities For Software Version 1.20 - 1.40" on page 134 or "Table 71: Event Type Polarities Only For Software Version 1.10" on page 135. This determines whether the output remains operating for the duration of the event, pulses for the duration, operates once only (one shot) or latches on.
<b>How Long To Operate For</b>	Is determined by a time base and a multiplier. Refer to "Timing" on page 136 for further details.
<b>How Often To Operate For</b>	Is determined by a time base and a multiplier. Refer to "Timing" on page 136 for further details.

## Output Configurations

**Output 1** Location 540 - 545

0 0	0	0	0 0
Event Type	Polarity	Time Base	Time Multiplier

*Default For EDMSAT Operation*

**Output 4** Location 558 - 563

2 0	1	0	0 0
Event Type	Polarity	Time Base	Time Multiplier

*Default For Strobe Operation*

**Output 2** Location 546 - 551

0 0	0	0	0 0
Event Type	Polarity	Time Base	Time Multiplier

*Default For EDMSTU Operation*

**Output 5** Location 564 - 569

1 15	1	0	0 0
Event Type	Polarity	Time Base	Time Multiplier

*Default For Screamer - RELAY*

**Output 3** Location 552 - 557

0 1	10	2	0 3
Event Type	Polarity	Time Base	Time Multiplier

*Default For Smoke Reset Operation*

**Output 6** Location 570 - 575

0 12	2	1	0 1
Event Type	Polarity	Time Base	Time Multiplier

*Default For Codepad Buzzer*

**The following outputs are available via an optional plug-on 8 Channel Output Expansion Board (CC884)**

**Output 7** Location 576 - 581

5 2	6	3	1 0
Event Type	Polarity	Time Base	Time Multiplier

*Default For Siren Operation - Area 1*

**Output 11** Location 600 - 605

5 4	6	3	1 0
Event Type	Polarity	Time Base	Time Multiplier

*Default For Siren Operation - Area 3*

**Output 8** Location 582 - 587

5 2	6	3	6 0
Event Type	Polarity	Time Base	Time Multiplier

*Default For Strobe Operation - Area 1*

**Output 12** Location 606 - 611

5 4	6	3	6 0
Event Type	Polarity	Time Base	Time Multiplier

*Default For Strobe Operation - Area 3*

**Output 9** Location 588 - 593

5 3	6	3	1 0
Event Type	Polarity	Time Base	Time Multiplier

*Default For Siren Operation - Area 2*

**Output 13** Location 612 - 617

5 5	6	3	1 0
Event Type	Polarity	Time Base	Time Multiplier

*Default For Siren Operation - Area 4*

**Output 10** Location 594 - 599

5 3	6	3	6 0
Event Type	Polarity	Time Base	Time Multiplier

*Default For Strobe Operation - Area 2*

**Output 14** Location 618 - 623

5 5	6	3	6 0
Event Type	Polarity	Time Base	Time Multiplier

*Default For Strobe Operation - Area 4*

## Redirecting Outputs To The Codepad Buzzer

Multiple output event types can be directed to the codepad buzzer so that it may be used to indicate any number of events.

This is achieved by selecting an output and programming it for the required output event type. When you are satisfied that the output is functioning correctly, change the first digit of the output event type (ie. The tens digit) by adding the value 8.

### Example

3,0

#### Communications Failure

This event will operate when the dialler has made all possible attempts to reach the base station receiver. It will reset when the first "Kiss-Off" is received. This output event type is not applicable to domestic or voice reporting.

To redirect the above output event type to operate a codepad buzzer, program the output event type as below:

11,0

#### Communications Failure

This event will operate when the dialler has made all possible attempts to reach the base station receiver. It will reset when the first "Kiss-Off" is received. This output event type is not applicable to domestic or voice reporting.

The codepad buzzer will now operate instead of the output that has been programmed. The output is no longer functional and cannot be used for any other output event type.

---

**Note:** If you have used all programmable outputs on the control panel and require an additional output, program the output event type on any output between 7-14 and redirect the output to the remote codepad buzzer. This enables you and your customer to save money on purchasing the additional 8 Channel Output Expansion Board (CC884).

---

## Safecom Remote Operation Of Outputs

Safecom can remotely operate up to 3 outputs on the *Solution* (SC8016) as well as Arm and Disarm from the ST1000 software in the Control Room. The *Solution* (SC8016) needs to be programmed for this function to work. Outputs that are to be operated via ST1000 software need to be programmed with the event codes 2,9 Remote control 2, 2,1,0 Remote control 3, 2,1,1 Remote control 4. These correspond to the ST1000 output 1,2,3.

### Example

If you wanted output 1 on the ST1000 to control output 2 on the *Solution* (SC8016) you would need to program "LOCATIONS" 546,547 with 2,9 (Remote control 2)

---

**Note:** You cannot use Remote Control 1 when operating outputs via Safecom as this is already used to arm/disarm the system via ST1000 software and CANNOT be CHANGED.

If Safecom is disabled or you don't wish to use the ST1000 software to remotely operate outputs , programming Remote operation of outputs is done as normal.

---

## Output Event Types

There are approximately ninety different output event types to choose from. Each output event type is designated by two numbers. These two numbers need to be programmed into the appropriate locations of the output being used to indicate when the output should operate.

---

**Note: All reset times are in reference to polarity 1 and 8. Reset times will vary depending on the polarity used.**

---

0,0

### EDMSAT - Satellite Siren (Output 1 Only)

This output controls all functions of an EDMSAT satellite siren (SS914). The option of speaker indication beeps will not operate via the EDMSAT for remote operations.

0,0

### EDMSTU - Securitel Unit (Output 2 Only)

This output controls all functions of an EDMSTU Securitel unit (CS800).

0,0

### PRINTER (Output 3 Only)

This output allows connection of a serial printer to be used to log all reports with a date and time stamp. Refer to "LOCATION 756" on page 89 to select the required baud rate that the serial printer will communicate.

0,1

### System Armed

This output will operate when the system is armed in the AWAY Mode, STAY Mode 1 or STAY Mode 2. It will reset when the system has been disarmed. If the system has been partitioned, this event will operate when all areas have been armed in either AWAY Mode or STAY Mode 1.

0,2

### System Disarmed

This output will operate when the system is in the disarmed state. It will reset as soon as the system becomes armed. If the system has been partitioned, this event will operate when all areas have been disarmed.

0,3

### Armed In STAY Mode

This output will operate when the system has been armed in STAY Mode 1 or STAY Mode 2. When the system has been partitioned, this event will operate when any area has been armed in STAY Mode 1 or STAY Mode 2.

0,4

### Armed In AWAY Mode (Software Version 1.20 Onwards)

This output will operate when the system has been armed in the AWAY Mode and will reset when the system is next disarmed. If the system has been partitioned, this event will operate when any area has been armed in the AWAY Mode.

0,4

### Pre-Arming Alert Time (Software Version 1.10)

This output will operate during the time period before the control panel will automatically arm in AWAY Mode or STAY Mode 1. Once the control panel has automatically armed in the AWAY Mode or STAY Mode 1, the output will reset. To program the Pre-Arming Alert Time, refer to "LOCATION 654" on page 144.

0,5

### Pre-Arming Alert Time (Software Version 1.20 Onwards)

This output will operate during the time period before the control panel will automatically arm in AWAY Mode or STAY Mode 1. Once the control panel has automatically armed in the AWAY Mode or STAY Mode 1, the output will reset. To program the Pre-Arming Alert Time, refer to "LOCATION 654" on page 144.

0,6

### Exit Warning With All Zones Sealed Or Entry Warning

This output will operate during exit time when the control panel has been armed in AWAY Mode, STAY Mode 1 or STAY Mode 2 if all zones are sealed. This output event type will reset once exit time has expired.

The next time this output event type will operate will be during entry time and will reset once entry time has expired or the system has been disarmed. This output event type will also operate if a zone has triggered when the system has been armed in STAY Mode 1 or STAY Mode 2 if the Entry Guard Timer For STAY Mode has been programmed in "LOCATION 638 - 639" on page 141.

0,7

### Exit Warning

This output operates during exit time when the system has been armed in AWAY Mode, STAY Mode 1 or STAY Mode 2. The output will reset once exit time has expired.

0, 8

**Exit Warning Finished**

This output operates when the exit time has expired if the system has been armed in AWAY Mode, STAY Mode 1 or STAY Mode 2. The output will reset when the system has been disarmed.

0, 9

**Kiss-Off After End Of Exit Time**

This output will operate after the first successful transmission to the base station receiver when exit time has expired. The output will reset when the system has been disarmed.

0, 11

**Entry Warning**

This output will operate when either Entry Timer 1, Entry Timer 2, Entry Timer 3, Entry Timer 4 or Entry Guard Timer For STAY Mode are operating. The output will reset when the entry time expires.

0, 12

**Entry Warning + Day Alarm Resetting**

This output combines both Entry Warning and Day Alarm Resetting so that either of these two events will activate the output.

If the output has been triggered by either Entry Timer 1, Entry Timer 2, Entry Timer 3, Entry Timer 4 or Entry Guard Timer For STAY Mode, the output will reset once the entry timer has expired or the system has been disarmed.

If the output has been triggered by a zone programmed for day alarm, the output will reset when the zone has resealed.

0, 14

**Day Alarm Resetting**

This output will operate when a zone programmed for day alarm has been triggered. The output will reset when the day alarm zone has resealed.

0, 15

**Day Alarm Latching**

This output will operate when a zone programmed for day alarm has been triggered. The output will reset when the **AWAY** button has been pressed.

If the control panel has been partitioned, pressing the **AWAY** button on a "CP5 Area Addressable (CP500A)" codepad other than that the zone was allocated or pressing the **AWAY** button on a "CP5 Master Partitioned Codepad (CP500P)" codepad will not reset the output. You can only reset this output on the area codepad that the zone has been allocated to when the system has been partitioned.

1, 0

**Day Alarm Enabled (Software Version 1.20 Onwards)**

This output will operate as soon as day alarm has been enabled. The output will reset when day alarm has been turned off. Refer to "Hold Down Functions" on page 61 for further information day alarm.

1, 1

**Timed Output**

This output will operate when the time set in "LOCATION 656 - 659" on page 145 has been reached. This output can also be activated using the following methods:

1. Remote Codepad - Refer to "Turning Outputs On and Off" on page 57 for more information.
2. Via Touch Tone Telephone - Refer to "Operating The Control Panel Using The DTMF Command Module" on page 67 and "Turning Outputs On and Off" on page 57 for more information.
3. Via Alarm Link Software (CC816) - Refer to the Alarm Link Instruction Manual for more information.

1, 2

**Pre-Alert Warning For Timed Output**

This output will operate for the duration of the pre-alert time set in "LOCATION 655" on page 145.

1, 4

**AC Fail**

This output will operate as soon as the AC mains has failed. It will reset as soon as the AC mains has restored. This output will operate irrespective if Option 4 in "LOCATION 668" on page 156 has been enabled or disabled.



1, 5

**Low Battery**

This output will operate when a dynamic battery test detects that the battery has failed or the battery voltage has fallen below 10.5 volts. The dynamic battery test is performed every four hours from when the system has been powered up or every time the system has been armed in AWAY Mode, STAY Mode 1 or STAY Mode 2.

This output will reset only after a dynamic battery test reports the backup battery is OK.

1, 6

**Horn Speaker Fail**

If Option 4 in "LOCATION 665" on page 152 has been enabled, this output will operate when the horn speaker has been disconnected. The output will reset when the horn speaker has been reconnected.

1, 7

**Sensor Watch Alarm**

This output will operate when the sensor watch count has been reached. Refer to "Zone Options" on page 107 for more information on programming zones for sensor watch. Refer to "LOCATION 642 - 643" on page 142 for setting how many days before a zone can register as a faulty sensor watch zone.

1, 8

**Codepad Medical Alarm (New - Software Version 1.37 Onwards)**

This output will operate when a codepad medical alarm has been initiated by pressing the 7 and 9 buttons on the remote codepad simultaneously. This output will reset once a valid user code has been entered.

1, 9

**Codepad Fire Alarm (New - Software Version 1.37 Onwards)**

This output will operate when a codepad medical alarm has been initiated by pressing the 4 and 6 buttons on the remote codepad simultaneously. This output will reset once a valid user code has been entered.

1, 10

**Codepad Panic Alarm (Software 1.10 - 1.36)**

This output will operate when a codepad panic alarm (audible or silent) has been initiated by pressing the 1 and 3 buttons, the 4 and 6 buttons, the 7 and 9 buttons or the STAY and AWAY buttons on the remote codepad simultaneously. This output will reset once a valid user code has been entered.

1, 10

**Codepad Panic Alarm (Software 1.37 Onwards)**

This output will operate when a codepad panic alarm (audible or silent) has been initiated by pressing the 1 and 3 buttons or the STAY and AWAY buttons on the remote codepad simultaneously. This output will reset once a valid user code has been entered at the remote codepad.

1, 11

**Codepad Duress Alarm**

This output will operate when a duress alarm has been initiated by adding a 9 to the end of the user code being used to disarm the system. The output will reset the next time the system has been armed.

1, 12

**Codepad Tamper**

This output will operate when the wrong code has been entered more times than allowed. Refer to "LOCATION 338" on page 101 for setting the number of incorrect attempts that may be allowed. This output will reset once a valid user code has been entered.

1, 13

**Speaker Beeps (New - Software Version 1.37)**

This output will function during all remote radio/keyswitch operations allowing you to fit a 12V DC buzzer or light to provide status indication for the end user. Option 8 in "LOCATION 665" on page 152 is not required to be enabled for this event type to operate. Refer to "Table 69: Horn Speaker Beeps" for the identification beeps and their meanings.

No Of Beeps	System Status
1	System Disarmed
2	System Armed In AWAY Mode
3	System Armed In STAY Mode 1

Table 69: Horn Speaker Beeps

1, 15

**Sirens Running**

This output will operate for the duration of the siren run time programmed in "LOCATION 660" on page 145. When the sirens have been activated, this output will reset once the siren run time has expired.

2, 0

**Strobe Operating**

This output will operate when an alarm condition occurs and will reset once a valid user code has been entered, or when the system is next armed or disarmed.

2, 1

**Silent Alarm**

This output will operate whenever a zone programmed as silent has triggered. The output will reset when the siren run time expires, an audible alarm has triggered, or a valid user code has been entered.

2, 2

**Alarm When In STAY Mode**

This output will operate whenever an audible or silent zone alarm has triggered when the system has been armed in STAY Mode 1 or STAY Mode 2. The output will reset when the system has been disarmed.

2, 3

**Alarm When In AWAY Mode**

This output will operate whenever an audible or silent zone alarm has triggered when the system has been armed in the AWAY Mode. The output will reset when the system has been disarmed.

2, 5

**Fire Alarm Resetting**

This output will operate when a 24 hour fire zone is triggered. The output will reset once a valid user code has been entered or when siren run time expires. If the control panel has been partitioned, a user code allocated to another area may reset this output.

2, 6

**Fire Alarm Latching**

This output will operate when a 24 hour fire zone has triggered and will reset when the system has been armed or disarmed. If the system has been partitioned, the output will reset when any area has been armed or disarmed.

2, 7

**Fire Alarm Verification (New - Software Version 1.37 Onwards)**

This feature is used on some commercial fire control panels to reduce false alarms on smoke detectors. It is conceptually very similar to zone pulse count as used in some motion detectors. Basically, a fire zone is allotted a pulse count of 3 pulses over a period of 3 minutes.

If the smoke detector trips, the voltage to the smoke detector is disconnected for 15 seconds and then reapplied. No alarm has registered.

If within 3 minutes of the first trigger the unit triggers again, no alarm will be registered and the voltage to the smoke detector will again be disconnected for 15 seconds and then reapplied.

If a third trigger is detected within 3 minutes of the first trigger, (ie. 3 pulses in 3 minutes) a fire alarm will be registered. Power to the smoke detector will be maintained to facilitate unit identification via the detector memory.

This output should be connected to the negative side of any fire/smoke detector. To configure an output for this feature, use the following settings.

EVENT TYPE = 2,7      POLARITY = 10      TIMEBASE = 2      MULTIPLIER = 15

The zone that the fire/smoke detector is connected to should be programmed as follows:

ZONE TYPE = 13      OPTION = 0      ZONE PULSE COUNT = 3      ZONE TIME = 15

2, 8

**Remote Control 1**

2, 9

**Remote Control 2**

2, 10

**Remote Control 3**

2, 11

**Remote Control 4**

These outputs can be remotely activated (Turned "On" or "Off") via the following methods:

1. Remote Codepad - Refer to "Turning Outputs On and Off" on page 57 for further information.
2. Remotely Via Touch Tone Phone - Refer to "Operating The Control Panel Using The DTMF Command Module" on page 67 and "Turning Outputs On and Off" on page 57 for further information.
3. Remotely Via Alarm Link Software - Refer to your Alarm Link Instruction Manual for further information.
4. Remotely Via Safecom Radio Link – Refer to Safecom Remote Operation Of Outputs on page 126 for further information.

2, 12

**Auxiliary Code 1**

This output will operate when Auxiliary Code 1 has been entered. The output will reset when Auxiliary Code 1 has been entered again. The output can be activated via the remote codepad, the Alarm Link Software (CC816) or a touch tone telephone if a DTMF Command Module (CC886) has been enabled and connected to the control panel.

2, 13

**Auxiliary Code 2**

This output will operate when Auxiliary Code 2 has been entered. The output will reset when Auxiliary Code 2 has been entered again. The output can be activated via the remote codepad, the Alarm Link Software (CC816) or a touch tone telephone if a DTMF Command Module (CC886) has been enabled and connected to the control panel.

2, 14

**Telephone Line Fault**

This output will operate when the Solution Line Fault Module (CC887) detects that the telephone line has been disconnected for more than 40 seconds. The output will reset once the telephone line has been restored continuously for more than 40 seconds. This output will not operate unless the Solution Line Fault Module (CC887) has been enabled in "LOCATION 673" on page 164.

2, 15

**Communications Failure After 3 Unsuccessful Calls**

This output will operate when the communication dialler has made 3 unsuccessful calls to the base station receiver. The output will reset when all messages have been transmitted (ie. When the buffer is empty or when all possible attempts have been made).

3, 0

**Communications Failure**

This event will operate when the communication dialler has made all possible attempts to reach the base station receiver. It will reset when the first "Kiss-Off" has been received. This output does not operate for domestic or voice reporting formats.

3, 1

**Dialler Disabled**

This output will operate as long as the communication dialler has been disabled in "LOCATION 663" on page 150. The output will reset once the dialler reporting functions has been enabled in "LOCATION 663".

3, 2

**Dialler Active**

This output will operate when the communication dialler is on-line. The output will reset when the communication dialler has released the telephone line.

3, 3

**Ring Detect (New - Software Version 1.37 Onwards)**

This output will operate when an incoming call has been detected. The output will reset when the ringing has stopped or when the call has been answered.

<b>3, 5</b>	<b>Mimic Zone 1</b>	<b>3, 13</b>	<b>Mimic Zone 9</b>
<b>3, 6</b>	<b>Mimic Zone 2</b>	<b>3, 14</b>	<b>Mimic Zone 10</b>
<b>3, 7</b>	<b>Mimic Zone 3</b>	<b>3, 15</b>	<b>Mimic Zone 11</b>
<b>3, 8</b>	<b>Mimic Zone 4</b>	<b>4, 0</b>	<b>Mimic Zone 12</b>
<b>3, 9</b>	<b>Mimic Zone 5</b>	<b>4, 1</b>	<b>Mimic Zone 13</b>
<b>3, 10</b>	<b>Mimic Zone 6</b>	<b>4, 2</b>	<b>Mimic Zone 14</b>
<b>3, 11</b>	<b>Mimic Zone 7</b>	<b>4, 3</b>	<b>Mimic Zone 15</b>
<b>3, 12</b>	<b>Mimic Zone 8</b>	<b>4, 4</b>	<b>Mimic Zone 16</b>

These output types will mimic the zone inputs. The output will operate when the zone is unsealed and will reset when the zone has resealed. They will operate regardless of the zone type chosen (ie. A zone "Not Used" can still operate a mimic output). This feature operates when the system is armed or disarmed.

#### **4, 5** Global Chime

This output will operate when any zones programmed as "Chime" have triggered. The output will reset when the zone has resealed.

#### **4, 6** Zone Not Sealed

This output will operate whenever a burglary zone is unsealed. Chime zones will not operate this output event type.

#### **4, 7** Zone Not Sealed After Exit Time

This output will operate at the end of exit time if a burglary zone is unsealed. The output will reset when all zones are sealed or the system has been disarmed. Chime zones will not operate this output event type.

#### **4, 10** Area 1 Has Zone Unsealed

#### **4, 12** Area 3 Has Zone Unsealed

#### **4, 11** Area 2 Has Zone Unsealed

#### **4, 13** Area 4 Has Zone Unsealed

These outputs will operate when a zone in their corresponding area has registered as unsealed in either the armed or disarmed state. The output will reset once the zone has resealed.

#### **Example**

Zone 1 is allocated to Area 1. If Zone 1 becomes unsealed, Output Event Type 4,10 will activate. The output will reset once the zone has resealed.

#### **5, 1** AC Mains 60 Hz Or 50 Hz

This output will activate when the AC mains has a frequency of 60 Hz. The output will reset once the AC mains has returned to 50 Hz.

#### **5, 2** Area 1 In Alarm

#### **5, 4** Area 3 In Alarm

#### **5, 3** Area 2 In Alarm

#### **5, 5** Area 4 In Alarm

These outputs will operate when a zone in their corresponding area has triggered an alarm. These outputs will reset once a valid user code has been entered.

#### **Example**

Zone 1 has been allocated to Area 1. If zone 1 has triggered into alarm, Output Event Type 5,2 will activate. The output will reset once a valid user code allocated to Area 1 has been entered.

5, 6

**Area 1 Is Armed**

5, 8

**Area 3 Is Armed**

5, 7

**Area 2 Is Armed**

5, 9

**Area 4 Is Armed**

These outputs will operate once their corresponding area has been armed in either AWAY Mode or STAY Mode 1. The output will reset once the corresponding area has been disarmed.

**Example**

If Area 1 has been armed in AWAY Mode or STAY Mode 1, Output Event Type 5,6 will activate. The output will reset once Area 1 has been disarmed.

5, 10

**Area 1 Is Disarmed**

5, 12

**Area 3 Is Disarmed**

5, 11

**Area 2 Is Disarmed**

5, 13

**Area 4 Is Disarmed**

These outputs will operate once their corresponding area has been disarmed. The output will reset once the corresponding area has been armed in AWAY Mode or STAY Mode 1.

**Example**

If Area 1 has been disarmed, Output Event Type 5,10 will operate. If Area 1 has been armed in AWAY Mode or STAY Mode 1, the output will reset.

5, 14

**Any Areas Armed**

5, 15

**Any Areas Disarmed**

Output Event Type 5,14 will operate when any area becomes armed if the control panel has been partitioned. The output will reset when all areas have been disarmed.

Output Event Type 5,15 will operate when any area becomes disarmed if the control panel has been partitioned. The output will reset when all areas have been armed.

6, 0

**Area 1 Codepad Data**

6, 2

**Area 3 Codepad Data**

6, 1

**Area 2 Codepad Data**

6, 3

**Area 4 Codepad Data**

If the control panel has been partitioned, "CP5 Area Addressable (CP500A)" codepads are required to be connected to separate outputs and programmed for the required area that the codepad belongs to.

Refer to "Codepad Connections For Partitioning" on page 180 for further information on connecting the "CP5 Area Addressable (CP500A)" codepads to the control panel.

**Example**

If the Area 1 codepad is to be connected to Output 2, you would then set DIP Switch 1 on the back of the "CP5 Area Addressable (CP500A)" codepad into the "ON" position. For the Area 1 codepad to communicate to and from the control panel, Output 2 will need to be programmed with Output Event Type 6,0.

Only Outputs 1 - 4 on the control panel can be used for these output event types. The 8 Channel Output Expansion Board (CC884) cannot be used for these output event types.

## Output Polarity - (Software Version 1.20 - 1.40)

There are fifteen different polarities to choose from. Each polarity is designated by a number. This number needs to be programmed into the appropriate location of the output being used to indicate how the output should operate.

Option	Polarity	Option	Polarity
0	Output Not Used		
1	Normally Open, Going Low	8	Normally Low, Going Open
2	Normally Open, Pulsing Low	9	Normally Low, Pulsing Open
3	Normally Open, One Shot Low	10	Normally Low, One Shot Open
4	Normally Open, One Shot Low (Retrigger)	11	Normally Low, One Shot Open (Retrigger)
5	Normally Open, One Shot Low (Can Reset)	12	Normally Low, One Shot Open (Can Reset)
6	Normally Open, One Show Low (Alarm)	13	Normally Low, One Shot Open (Alarm)
7	Normally Open, Latching Low	14	Normally Low, Latching Open

Table 70: Event Type Polarities For Software Version 1.20 - 1.40

### 0 Output Not Used

If an output is not required for use, the polarity should be programmed as zero.

### 1 Normally Open, Going Low

This polarity is normally open circuit and will switch to zero volts when the event occurs. The output will switch back to open circuit when the event has restored. Time parameters are not applicable to this polarity.

### 2 Normally Open, Pulsing Low

This polarity is normally open circuit and will switch to pulsing zero volts when the event occurs. It will switch back to open circuit when the event has restored. Time parameters vary the "On" time of the pulse.

### 3 Normally Open, One Shot Low

This one shot polarity is normally open circuit and will switch to zero volts when the event occurs. It will switch back to open circuit when the time parameter setting has expired. This one shot time setting will always run its full duration and cannot be manually reset.

### 4 Normally Open, One Shot Low With Retrigger

This one shot polarity is normally open circuit and will switch to zero volts when the event occurs. Every time the event occurs, it will restart the one shot timer. The output will switch back to open circuit once the one shot time has expired.

This polarity is ideally suited for lighting control. A PIR can be used to trigger an output for turning on lights. While ever there is movement, the PIR will keep re-triggering the output and lengthen the time the lights will remain switched on.

### 5 Normally Open, One Shot Low With Reset

This one shot polarity is normally open circuit and will switch to zero volts when the event occurs. The output will switch back to open circuit when the one shot time has expired or when the event has returned to normal. This means the operation of the output can be shortened regardless of the time parameter.

### 6 Normally Open, One Shot Low With Alarm

This one shot polarity is normally open circuit and will switch to zero volts when the event occurs. The output will switch back to open circuit once the one shot time has expired, when the event has returned to normal or when the system has been disarmed.

This polarity is ideally suited for the operation of strobe lights as they can be timed (Up to 99 hours) to reset and prevent them from burning out or becoming annoying to others from prolonged operation.

### 7 Normally Open, Latching Low

This polarity is normally open circuit and will switch to zero volts when the event occurs. The output will switch back to open circuit once the 7 button on the remote codepad is held down until two beeps are heard. Time parameters are not applicable to this polarity.

**8 Normally Low, Going Open**

This polarity is normally zero volts and will switch to open circuit when the event occurs. The output will switch back to zero volts when the event has restored. Time parameters are not applicable to this polarity.

**9 Normally Low, Pulsing Open**

This polarity is normally zero volts and will switch to pulsing open circuit when the event occurs. It will switch back to zero volts when the event has restored. Time parameters vary the "On" time of the pulse.

**10 Normally Low, One Shot Open**

This one shot polarity is normally zero volts and will switch to open circuit when the event occurs. The output will switch back to zero volts when the time parameter has expired. This one shot time setting will always run its full duration and cannot be manually reset.

**11 Normally Low, One Shot Open With Retrigger**

This one shot polarity is normally zero volts and will switch to open circuit when the event occurs. Every time the event occurs, it will restart the one shot timer. The output will switch back to zero volts once the one shot time has expired.

**12 Normally Low, One Shot Open With Reset**

This one shot polarity is normally zero volts and will switch to open circuit when the event occurs. The output will switch back to zero volts when the one shot time has expired or when the event has returned to normal. This means the one shot timer can be shortened regardless of the time setting.

**13 Normally Low, One Shot Open With Alarm**

This one shot polarity is normally zero volts and will switch to open circuit when the event occurs. The output will switch back to zero volts when the one shot time has expired, when the event has returned to normal or when the system has been disarmed. This means that the one shot timer can be shortened regardless of the time setting.

**14 Normally Low, Latching Open**

This polarity is normally zero volts and will switch to open circuit when the event occurs. The output will switch back to zero volts once the 7 button on the remote codepad has been held down until two beeps are heard. Time parameters are not applicable to this polarity.

**Output Polarity - (Software Version 1.10 Only)**

There are thirteen different polarities to choose from. Each polarity is designated by a number. This number needs to be programmed into the appropriate location of the output being used to indicate how the output should operate.

---

**Note:** Refer to "Output Polarity - (Software Version 1.20 - 1.40)" on page 134 for the description of the different polarity types.

---

<b>Option</b>	<b>Polarity</b>	<b>Option</b>	<b>Polarity</b>
<b>0</b>	Output Not Used		
<b>1</b>	Normally Open, Going Low	<b>8</b>	Normally Low, Going Open
<b>2</b>	Normally Open, Pulsing Low	<b>9</b>	Normally Low, Pulsing Open
<b>3</b>	Normally Open, One Shot Low	<b>10</b>	Normally Low, One Shot Open
<b>4</b>	Normally Open, One Shot Low (Can Reset)	<b>11</b>	Normally Low, One Shot Open (Can Reset)
<b>5</b>	Normally Open, One Shot Low (Retrigger)	<b>12</b>	Normally Low, One Shot Open (Retrigger)
<b>6</b>	Normally Open, Latching Low	<b>13</b>	Normally Low, Latching Open

*Table 71: Event Type Polarities Only For Software Version 1.10*

## Timing Of Outputs

The timing of outputs is calculated by a time base and a multiplier. These two values play different roles depending on the polarity selected. When programming pulsing outputs, both the "On" and "Off" times can be set. One shot polarities can be timed between 200 ms up to 99 hours in duration.



The maximum value that can be programmed in the two multiplier locations is 9,9.

Option	Time Base
1	200 ms
2	1 Second
3	1 Minute (60 Seconds)
4	1 Hour (60 Minutes)

Table 72: Time Base Settings

The time base settings can be set to only one of the values listed in "Table 72: Time Base Settings". This is not like other options where more than one can be selected and the option numbers added together to give various combinations. The multiplier value is a two digit decimal number from 00-99. For greater accuracy, use 60 seconds for 1 minute intervals and use 60 minutes for one hour intervals.

## Pulsing Polarities

When calculating pulsing polarities both the "On" and "Off" times need to be set. The duration or "On" time of an output is determined by selecting only one of the time bases from "Table 72: Time Base Settings" on page 136. This means there are only four "On" times to choose from.

The "Off" time is calculated as a multiple of the "On" time by choosing a decimal number between 0 and 99. If an output is required to operate for 200 ms every five seconds, program the time settings as follows;

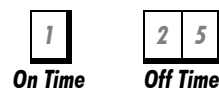

ON Time	OFF Time	Increments	Tolerance
200 ms	200 ms - 19.8 ms	200 ms	+/- 200 ms
1 Sec	1 Sec - 99 Sec's	1 Sec	+/- 1 Sec
1 Min	1 Min - 99 Min's	1 Min	+/- 1 Min
1 Hour	1 Hour - 99 Hours	1 Hour	+/- 1 Hour

Table 73: Pulsing Time Settings



## One Shot Polarities

The duration or "On" time of an output is determined by the product of the time base and the multiplier.

If an output is required to operate for five seconds, program the time settings as follows;

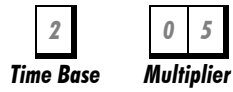

The "On" time is calculated by multiplying the time base setting (1 second) by the multiplier value (05).  
 (ie. 5 x 1 = 5 seconds)

<b>On Time</b>	<b>Increments</b>	<b>Tolerance</b>
200 ms - 19.8 Sec's	200 ms	+/- 200 ms
1 Sec - 99 Sec's	1 Sec	+/- 1 Sec
1 Min - 99 Min's	1 Min	+/- 1 Min
1 Hour - 99 Hours	1 Hour	+/- 1 Hour

*Table 74: One Shot Time Settings*



# System Event Timers

---

## **This Section Includes The Following:**

- *How To Program Entry/Exit Timers*
- *Entry Timer 1*
- *Entry Timer 2*
- *Entry Timer 3*
- *Entry Timer 4*
- *Exit Timer For AWAY Mode*
- *Exit Timer For STAY Mode 1*
- *Exit Timer For STAY Mode 2*
- *Entry Guard Timer For STAY Mode*
- *Codepad Lockout Time*
- *Sensor Watch Time*
- *Safecom RF Jamming Delay*
- *System Date*
- *Auto Arming*
- *Auto Arming Pre-Alert Timer*
- *Auto Operation Pre-Alert Timer*
- *Auto Operation Of The Timed Output*
- *Siren Run Time*
- *Siren Sound Rate*
- *Swinger Shutdown Count*
- *Swinger Shutdown Count For Siren*
- *Swinger Shutdown Count For Dialler*
- *System Time*

## System Event Timers

This section covers the features that involve timing. Features such as entry and exit times, sensor watch time, siren run time and system date and time along with a host of other timers are discussed extensively in this section.

### How To Program Entry/Exit Timers

There are two locations to be programmed for Entry Timer 1, Entry Timer 2, Exit Time For AWAY Mode, Exit Time For STAY Mode 1/STAY Mode 2 and Entry Guard Time For STAY Mode.

The first location of the timer is for programming increments of between 0 - 15 seconds. The second location of the timer is for programming increments of 16 seconds. By adding these two locations together will give the total time required.

### Entry Time

The *Solution-16* control panel has four separate entry timers. Entry time can be programmed between 0 and 255 seconds in increments of one second. These will prove to be helpful when the control panel has been partitioned or in any installation that requires more than one entry timer.

#### Entry Timer 1

LOCATION 624 - 625 (Defaulted To 10 Seconds)

10 0

Location	Description
624	1 Second Increments For Entry Timer 1
625	16 Second Increments For Entry Timer 1

Table 75: Entry Timer 1 Locations

#### Entry Timer 2

LOCATION 626 - 627 (Defaulted To 20 Seconds)

4 1

Location	Description
626	1 Second Increments For Entry Timer 2
627	16 Second Increments For Entry Timer 2

Table 76: Entry Timer 2 Locations

#### Entry Timer 3

LOCATION 628 - 629 (Defaulted To 30 Seconds)

14 1

Location	Description
628	1 Second Increments For Entry Timer 3
629	16 Second Increments For Entry Timer 3

Table 77: Entry Timer 3 Locations

#### Entry Timer 4

LOCATION 630 - 631 (Defaulted To 40 Seconds)

8 2

Location	Description
630	1 Second Increments For Entry Timer 4
631	16 Second Increments For Entry Timer 4

Table 78: Entry Timer 4 Locations

## Exit Time

The control panel has three separate exit timers. Exit time can be programmed to be between 0 and 255 seconds in increments of one second. The remote codepad will always give one beep at the end of exit time when arming in AWAY Mode or one short beep at the end of exit time when arming in STAY Mode 1 or STAY Mode 2.

### Exit Timer For AWAY Mode

LOCATION 632 - 633 (Defaulted To 60 Seconds)

12 3

Location	Description
632	1 Second Increments For Exit Timer For AWAY Mode
633	16 Second Increments For Exit Timer For AWAY Mode

Table 79: Exit Timer For AWAY Mode Locations

### Exit Timer For STAY Mode 1

LOCATION 634 - 635 (Defaulted To 60 Seconds)

12 3

Location	Description
634	1 Second Increments For Exit Timer For STAY Mode 1
635	16 Second Increments For Exit Timer For STAY Mode 1

Table 80: Exit Timer For STAY Mode 1 Locations

### Exit Timer For STAY Mode 2

LOCATION 636 - 637 (Defaulted To 60 Seconds)

12 3

Location	Description
636	1 Second Increments For Exit Timer For STAY Mode 2
637	16 Second Increments For Exit Timer For STAY Mode 2

Table 81: Exit Timer For STAY Mode 2 Locations

### Entry Guard Timer For STAY Mode

LOCATION 638 - 639 (Defaulted To 60 Seconds)

12 3

Location	Description
638	1 Second Increments For Entry Guard Timer For STAY Mode
639	16 Second Increments For Entry Guard Timer For STAY Mode

Table 82: Entry Guard Timer For STAY Mode Locations

"Entry Guard Timer For STAY Mode" is the delay time used for ALL ZONES except 24 hour burglary and 24 hour fire zones when the system is armed in STAY Mode 1 or STAY Mode 2. Each zone including delay zones will have the entry delay as programmed in "LOCATION 638 - 639" (ie. The delay time programmed for a delay zone will be overridden by the entry guard timer). If the entry guard timer has been programmed as "0" each zone will act as per its programmed zone type.

**Codepad Lockout Time****LOCATION 640 - 641**

0 0

<b>Location</b>	<b>Description</b>
640	1 Second Increments For Codepad Lockout Time
641	16 Second Increments For Codepad Lockout Time

*Table 83: Codepad Lockout Timer Locations*

All codepads will be locked out for the specified time programmed if the wrong code has been entered more times than allowed by the code retry attempts in "LOCATION 338" on page 101. If the "Codepad Lockout Time" is programmed as zero, no lockout will occur.

**Sensor Watch Time****LOCATION 642 - 643**

0 0

<b>Location</b>	<b>Description</b>
642	Number Of Days (Tens Digit)
643	Number Of Days (Units Digit)

*Table 84: Sensor Watch Timer Locations*

The time set in these two locations determines how many days (0-99) a zone may remain sealed before registering as a fault. This feature is only active when the system is in the disarmed state. If a zone programmed for sensor watch has not triggered and reset during this time, the FAULT indicator will illuminate. Refer to "Fault Descriptions" on page 42 for further information on sensor watch faults.

**Safecom RF Jamming Delay****LOCATION 772**

(Safecom Only)

0

<b>Location</b>	<b>Description</b>
772	Increments of Minutes (0 – 15 minutes)

*Table 85: RF Jamming Delay Time*

This is used to set the amount of time that the safecom interface detects continuous signal before reporting RF Jamming to the base station receiver via the safecom network, if it can't get through, then the panel will attempt to report via the telephone line. If reporting can not get through via the safecom network or via the telephone network then the fault indicator will illuminate. Refer to "Fault Descriptions" on page 45 for further information.

**Safecom RF Supervision Time****LOCATION 773**

(Safecom Only)

10

<b>Location</b>	<b>Description</b>
773	Increments of Minutes (0 – 15 minutes)

*Table 86: RF Supervision Time*

The RF Supervision Time is used to monitor safecom activity within the same framer. It is used to ensure that the receiver is not deaf in between status polls from the base station. This is the time in minutes that the receiver must receive a valid safecom packet on the same framer before timing out.

If the RF Supervision Timer expires before a valid packet is received, the system will initiate a back poll to validate that the ST1000 interface is truly not present. If the back poll fails, an RF Fail report is then sent to the base station receiver via the telephone line. To disable this function, program the time to zero. Refer to Safecom RF Fail on page 121 for more information on reporting.

**System Date**

LOCATION 644 - 649 (Software Version 1.20 - 1.40)

0 1 0 1 9 5

Location	Description
644	Day Of The Month (Tens Digit)
645	Day Of The Month (Units Digit)
646	Month Of The Year (Tens Digit)
647	Month Of The Year (Units Digit)
648	Current Year (Tens Digit)
649	Current Year (Units Digit)

Table 87: System Date Locations (Software Version 1.20 - 1.40)

LOCATION 644 - 649 (Software Version 1.10 Only)

1 1 0 1 9 5

Location	Description
644	Day Of The Week (Sun = 1 Sat = 7)
645	Month Of The Year (Jan = 1 Dec = 12)
646	Day Of The Month (Tens Digit)
647	Day Of The Month (Units Digit)
648	Current Year (Tens Digit)
649	Current Year (Units Digit)

Table 88: System Date Locations (Software Version 1.10 Only)

*Solution-16* has a real time 12 month calendar that needs to be set during installation.

## Setting The Date and Time

This function needs to be used when the date and time requires to be changed or the system has been powered down.

### How To Set The New Date and Time

1. Enter your **MASTER CODE** followed by **6** and the **AWAY** button.  
Three beeps will be heard and the STAY and AWAY indicators will begin to flash.
2. Enter the day, month, year, hour and minute using the (DD, MM, YY, HH, MM) format.
3. Press the **AWAY** button when finished.  
Two beeps will be heard and the STAY and AWAY indicators will extinguish.

**MASTER CODE** + **6** + **AWAY**

### Example

If the date and time needs to be set for the 1st January 1996 at 10:00 PM, program the date and time as follows;

**MASTER CODE** + **6** + **AWAY**  
 + **0** + **1** + **0** + **1** + **9** + **6** + **2** + **2** + **0** + **0** + **AWAY**

**Auto Arming****LOCATION 650 - 653**

0 0 0 0

<b>Location</b>	<b>Description</b>
<b>650</b>	Actual Hour Of The Day (Tens Digit)
<b>651</b>	Actual Hour Of The Day (Units Digit)
<b>652</b>	Actual Minute Of The Day (Tens Digit)
<b>653</b>	Actual Minute Of The Day (Units Digit)

*Table 89: Auto Arming Locations*

This time parameter is used to select the actual time of the day that the system will automatically arm itself in the AWAY Mode or STAY Mode 1. This time must be set in 24 hour format (ie. 10:30 PM would be programmed as 2230). Refer to "LOCATION 668" on page 155 and page 156 for selecting whether the control panel should arm in the AWAY Mode or STAY Mode 1.

If forced arming has been disabled, the feature of auto arming will operate regardless of zones being sealed or unsealed.

If the control panel has been partitioned, ALL areas will automatically arm. If automatic arming is not required, program "LOCATION 650 - 653" with zeros.

**Auto Arming Pre-Alert Timer****LOCATION 654**

5

<b>Location</b>	<b>Description</b>
<b>654</b>	Pre-Alert Timer In 1 Minute Increments

*Table 90: Auto Arming Pre-Alert Timer Locations*

This is the time period before the control panel will automatically arm itself. The codepad will beep once every second until the pre-alert timer has expired, after which time the system will arm in the AWAY or STAY Mode 1.

Once the control panel has automatically armed in the AWAY Mode or STAY Mode 1, exit time will commence. If a valid user code has been entered during the pre alert time, the auto arming time as programmed in "LOCATION 650 - 653" will extend by one hour.

Refer to "Output Event Type - Pre-Arming Alert Time" on page 127 if you required an indication via a programmable output during the "Pre-Alert Timer".



**Auto Operation Pre-Alert Timer****LOCATION 655**

5

<i>Location</i>	<i>Description</i>
655	Auto Operation Pre-Alert Timer

*Table 91: Auto Operation Pre-Alert Timer Locations*

This location sets the amount of time in minutes (0-15) that will operate an output programmed with the "Output Event Type - Pre-Alert Warning For Timed Output" on page 128 to warn you before the timed output will automatically operate. Refer to "LOCATION 656 - 659" for programming the output time operation. Refer to "Output Event Types" on page 127 for more information.

**Auto Operation Of The Timed Output****LOCATION 656 - 659**

0 0 0 0

<i>Location</i>	<i>Description</i>
656	Actual Hour Of The Day (Tens Digit)
657	Actual Hour Of The Day (Units Digit)
658	Actual Minute Of The Day (Tens Digit)
659	Actual Minute Of The Day (Units Digit)

*Table 92: Auto Operation Of The Timed Output Locations*

These locations set the time of the day that an output programmed with "Output Event Type - Timed Output" will automatically operate. Refer to "Output Event Types" on page 127 for more information.

This time must be set in 24 hour format (ie. 10:30 PM would be programmed as 2230).

**Siren Run Time****LOCATION 660**

10

<i>Location</i>	<i>Description</i>
660	Siren Run Time - Increments Of 1 Minute

*Table 93: Siren Run Time Locations*

The siren run time determines how long the horn speaker will activate during alarm condition. The siren run time can be programmed between 0 - 15 minutes (+/- 1 minute).

**Siren Sound Rate****LOCATION 661**

7

<i>Location</i>	<i>Description</i>
661	Siren Sound Rate (0 = SLOWEST - 15 = FASTEST)

*Table 94: Siren Run Time Locations*

The siren sound rate varies the frequency of the siren tone. Zero rate is the slowest and fifteen is the fastest rate. This siren sound rate does not change the frequency rate for the fire alarm tone.

**Swinger Shutdown Count**

**LOCATION 662 (Software Version 1.10 - 1.37)**



<i>Location</i>	<i>Description</i>
662	Swinger Shutdown Count (0 - 15)

*Table 95: Swinger Shutdown Count Locations*

Swinger shutdown determines the amount of times the sirens and dialler can be triggered before any lockout options will take effect. A minimum of one zone must be programmed for lockout siren or lockout dialler for swinger shutdown to be effective.

Only alarms triggered from zone inputs will increment the swinger shutdown counter. This means alarms such as codepad panic, code retries and any other system alarms will not effect the swinger shutdown count.

While the sirens are operating, the counter for the sirens is only incremented by the first zone that causes the alarm. Any other zones that are triggered during siren time will not effect the counter. While the dialler is on line, its counter is only incremented by the first zone that causes the alarm. Any other zones that are triggered while the dialler is on line will not effect the counter.

When the swinger shutdown count (As programmed in "LOCATION 662") has been reached, all zones that have been triggered will be locked out according to their individual lockout settings.

If "Lockout Dialler" has been programmed for any zone, the last restore signal will not be transmitted until the system or area (if partitioned) has been disarmed.

**Swinger Shutdown Count For Siren****LOCATION 662 (Software Version 1.40 Only)**

<i>Location</i>	<i>Description</i>
662	Swinger Shutdown Count For Siren (0 - 15)

*Table 96: Swinger Shutdown Count For Siren Locations*

This location determines the amount of times the sirens can be triggered before any lockout options will take effect. A minimum of one zone must be programmed for lockout siren for this location to be effective.

Only alarms triggered from zone inputs will increment the swinger shutdown counter. This means alarms such as codepad panic, code retries and any other system alarms will not effect the swinger shutdown count.

While the sirens are operating, the counter for the sirens is only incremented by the first zone that causes the alarm. Any other zones that are triggered during siren time will not effect the counter. While the dialler is on line, its counter is only incremented by the first zone that causes the alarm. Any other zones that are triggered while the dialler is on line will not effect the counter.

When the swinger shutdown count (As programmed in "LOCATION 662") has been reached, all zones that have been triggered will be locked out according to their individual lockout settings.

**Swinger Shutdown Count For Dialler****LOCATION 757 (Software Version 1.40 Only)**

<i>Location</i>	<i>Description</i>
757	Swinger Shutdown Count For Dialler (0 - 15)

*Table 97: Swinger Shutdown Count For Dialler Locations*

This location determines the amount of times the dialler can be triggered before any lockout options will take effect. A minimum of one zone must be programmed for lockout dialler for this location to be effective.

Only alarms triggered from zone inputs will increment the swinger shutdown counter. This means alarms such as codepad panic, code retries and any other system alarms will not effect the swinger shutdown count.

While the sirens are operating, the counter for the dialler is only incremented by the first zone that causes the alarm. Any other zones that are triggered during siren time will not effect the counter. While the dialler is on line, its counter is only incremented by the first zone that causes the alarm. Any other zones that are triggered while the dialler is on line will not effect the counter.

When the swinger shutdown count (As programmed in "LOCATION 757") has been reached, all zones that have been triggered will be locked out according to their individual lockout settings.

---

**Note:** If "Lockout Dialler" has been enabled for any zone, the last restore signal will not be transmitted until the system or area (if partitioned) has been disarmed.

---

LOCATION 901 - 904

0000

Location	Description
901	Current Hour In 24 Hour Time (Tens Digit)
902	Current Hour In 24 Hour Time (Units Digit)
903	Current Minute (Tens Digit)
904	Current Minute (Units Digit)

Table 98: System Time Locations

The *Solution-16* control panel has a real time 24 hour clock that needs to be set during installation.

## Setting The Date and Time

This function needs to be used when the date and time requires to be changed or the system has been powered down.

### How To Set The New Date and Time

1. Enter your **MASTER CODE** followed by **6** and the **AWAY** button.  
Three beeps will be heard and the STAY and AWAY indicators will begin to flash.
2. Enter the day, month, year, hour and minute using the (DD, MM, YY, HH, MM) format.
3. Press the **AWAY** button when finished.  
Two beeps will be heard and the STAY and AWAY indicators will extinguish.

**MASTER CODE** + **6** + **AWAY**

### Example

If the date and time needs to be set for the 1st January 1996 at 10:00 PM, program the date and time as follows;

**MASTER CODE** + **6** + **AWAY**  
 + **0** + **1** + **0** + **1** + **9** + **6** + **2** + **2** + **0** + **0** + **AWAY**

# Option Bits

---

## **This Section Includes The Following:**

- *Dialler Options 1*
- *Dialler Options 2*
- *System Options 1*
- *System Options 2*
- *System Options 3*
- *System Options 4*
- *Consumer Options 1*
- *Consumer Options 2*
- *DTMF Command Module Options*
- *Expansion Board Type*
- *Telephone Line Fault Options*
- *Safecom Options*
- *System Options 5*
- *System Options 6*
- *Carrier Sync Options*

## Option Bits

When programming these locations you will notice that there are four options per location. You may select one, two, three or all four of these options, however, only one number needs to be programmed. This number is calculated by adding the option bit numbers together. Program a seven (7) if you require options 1, 2 and 4 simultaneously (ie.  $1+2+4=7$ ).

### Dialler Options 1

#### LOCATION 663

5

Option	Description
1	Enable Dialler Reporting Functions
2	Enable Remote Arming Via The Telephone
4	Enable Upload/Download Via Alarm Link
8	Terminate "Alarm Link" Session On Alarm

Table 99: Dialler Options 1

#### 1 Enable Dialler Reporting Functions

If this option has been enabled, the dialler will function for all operations. Upload/Download via Alarm Link Software (CC816) and telephone remote arming will remain operational regardless of this setting as long as a communication dialler hybrid has been fitted to the control panel.

##### Disable Dialler Reporting Functions

If this option is not enabled, the communication dialler will not operate. Upload/Download via Alarm Link Software (CC816) and telephone remote arming will remain operational regardless of this setting as long as a communication dialler hybrid has been fitted to the control panel. Safecom reporting will still function as normal with the dialler disabled.

#### 2 Enable Remote Arming Via The Telephone

If this option has been enabled, you can arm your control panel via a standard telephone using a Phone Controller (CC911). Refer to "Remote Arming Via The Telephone" on page 66 for more information. Forced arming is automatically assumed when this feature is being used. Refer to Option 1 in "LOCATION 665" on page 152 for further details on forced arming.

A communication dialler hybrid must be fitted to the control panel for this feature to operate. Whether the reporting functions of the dialler have been enabled or disabled (Refer to Option 1 of this location), this will have no effect on remote arming via the telephone. Refer to "Ring Count" on page 96 for programming the number of rings before the control panel will answer an incoming call.

#### 4 Enable Upload/Download Via Alarm Link Software

This option will need to be enabled if you require to use the Alarm Link Software (CC816) to remotely program the control panel. The control panel will not respond to the Alarm Link Software if this option has not been enabled.

For direct Upload/Download operations via the Direct Link Cable (CC808), this option does not need to be set. Whether the dialler reporting functions (Option 1 of this location) are enabled or disabled, this will have no effect on Upload/Download operations.

#### 8 Terminate Alarm Link Session On Alarm

If the control panel is communicating with a remote computer via Alarm Link Software (CC816) and an alarm has registered, the "Alarm Link" session will be terminated and the relevant alarm message will be transmitted to the base station receiver.

If an alarm occurs that does not need to report to the base station receiver, the session will not be terminated. If this option is not enabled and an alarm has registered, the Alarm Link software will prompt the operator with a "Terminate" or "Continue" message.

**LOCATION 664**

<b>Option</b>	<b>Description</b>
<b>1</b>	Send Open/Close Reports Only If A Previous Alarm Has Occurred
<b>2</b>	Enable First To Open/Last To Close Reporting When Partitioned
<b>4</b>	Send Open/Close Reports When Armed In STAY Mode 1 & 2
<b>8</b>	Enable Answering Machine Bypass Only When System Is Armed (New - Software Version 1.31 Onwards)

*Table 100: Dialler Options 2***1 Send Open/Close Report Only If A Previous Alarm Has Occurred**

This option requires Open/Close Reports in "LOCATION 504 - 505" enabled on page 120 for it to be effective.

An opening report will be transmitted to the base station receiver when the system has been disarmed after an alarm has occurred. When the system has been armed, a closing report will be transmitted. This feature can also be used in conjunction with the Patrolman Code. Refer to "Patrolman Code" on page 99 for more information.

If the system has been partitioned, an Open/Close report will only be transmitted on the area that the alarm had occurred.

---

**Note:** If the system is disarmed when an alarm occurs, only a closing report will be transmitted when the system is next armed.

---

**2 Enable First To Open, Last To Close Reporting When Partitioned**

This option needs to be enabled if only one Open/Close report is required when the system has been partitioned. Rather than having individual Open/Close reports for each area, a closing report will be transmitted only when ALL areas have been armed and an opening report will be transmitted as soon as one area has been disarmed.

The reports will be transmitted on the Subscriber ID Number allocated to that particular area. Subscriber ID Numbers and Open/Close reports must be programmed for all areas.

**4 Send Open/Close Reports When In STAY Mode 1 and STAY Mode 2**

If open and close reports are required when the system is armed in STAY Mode 1 or STAY Mode 2, this option will need to be enabled.

**8 Enable Answering Machine Bypass Only When System Is Armed (New - Software Version 1.31 Onwards)**

This option needs to be enabled if the answering machine bypass feature is required to operate only when the system has been armed. When the system is disarmed, the control panel will not answer any incoming calls. This option is beneficial in high telephone traffic installations where the control panel could answer an incoming call. Refer to "LOCATION 063" on page 96 to enable answering machine bypass.

**LOCATION 665**

1

<b>Option</b>	<b>Description</b>
<b>1</b>	Enable Forced Arming
<b>2</b>	Enable EDM Smart Lockout
<b>4</b>	Enable Monitoring Of Horn Speaker
<b>8</b>	Enable Horn Speaker Beeps For Remote Control Operation

*Table 101: System Options 1*

**1 Enable Forced Arming**

If this option has been selected, the system can be armed with zones unsealed.

If this option is not selected, all zones must be sealed before the system can be armed. An attempt to arm the system with forced arming not enabled will clear any alarm memories present but arming will not be permitted.

This feature will be ignored if the system has been set for auto arming in AWAY Mode or STAY Mode or has been remotely armed via the telephone using a Phone Controller (CC911), DTMF commands via the DTMF Command Module (CC886) or remote operation via the Radio Key/Keyswitch Interface (CC813).

**2 Enable EDM Smart Lockout**

This feature allows the control panel to remove any zones that are programmed for lockout from the lockout list while the sirens are running. This feature allows a monitoring station to receive codes from previously locked out zones during siren time.

**4 Enable Monitoring Of Horn Speaker**

If this option has been enabled, the control panel will detect when the horn speaker has been disconnected from the speaker terminals. The FAULT indicator will illuminate when the horn speaker has been disconnected and will extinguish when the horn speaker has been reconnected.

If an output is required to operate when the horn speaker has been disconnected, refer to "Output Event Type - Horn Speaker Fail" on page 129 for more information.

**8 Allow Horn Speaker Beeps For Radio Remote Control Operation**

<b>No Of Beeps</b>	<b>System Status</b>
<b>1</b>	System Disarmed
<b>2</b>	System Armed In AWAY Mode
<b>3</b>	System Armed In STAY Mode 1

*Table 102: Horn Speaker Beeps*

This feature will enable horn speaker beeps to be heard when the system is armed and disarmed via a hand held radio remote control unit. Devices connected to the bell output (RELAY OUTPUT) will not activate.

These speaker beeps are applicable when using the Radio Key/Keyswitch Interface (CC813) or connecting a switch to the JP5 pins (EXP + GND). If connecting a switch to the JP5 pins, enable the required input type in "LOCATION 672" on page 161.

---

**Note:** Arming the system in STAY Mode 1 will only sound the three beeps when carried out via a keyswitch interface. The two JP5 pins do not have access to this feature.

When using the Night Arm Station (CP105) to arm in STAY Mode 1, if this option has been enabled, three horn speaker beeps will be heard to indicate that the system has been armed in STAY Mode 1.

When using RE005 the transmitters must be programmed for single button Arm/Disarm if Speaker beeps are required.

---



## LOCATION 666

2

<b>Option</b>	<b>Description</b>
<b>1</b>	Enable Radio Key/Keypress Interface Or Night Arm Station
<b>2</b>	Enable Handover Delay To Be Sequential
<b>4</b>	Enable Codepad Panic To Be Silent
<b>8</b>	Enable Codepad Tamper To Be Silent

Table 103: System Options 2

**1 Enable Radio Key/Keypress Interface or Night Arm Station**

This option must be selected when using the Radio Key/Keypress Interface (CC813) , Night Arm Station (CP105) or the 2 Channel Radio Interface (RE005). This option allows the control panel to be operated using either of these two accessories.

**2 Enable Handover Delay To Be Sequential**

If this option has been enabled, handover delay will be sequential (ie. In numerical order from lowest to highest). If the sequence is broken before the entry time expires, an alarm will occur. If this option is not enabled, handover delay will follow the entry path provided that a delay zone has been triggered first.

**4 Enable Codepad Panic To Be Silent**

If this option has been enabled, a codepad panic alarm will not operate the horn speaker, the bell or the strobe outputs. If this option is not enabled, all three outputs will operate after a codepad panic alarm has been activated. Selecting this option does not effect the operation of the communication dialler.

---

**Note:** If the control panel has a Software Version Number 1.37 or higher, a codepad fire or a codepad medical alarm will be audible irrespective of this option being enabled or disabled.

To disable the codepad fire and codepad medical alarms, ALL codepad alarms will need to be disabled from transmitting alarms to the base station receiver. For this to be achieved, program "LOCATION 483" on page 117 as a zero. This will disable all reporting of codepad alarms and enable codepad fire and codepad medical alarms to be silent.

---

**8 Enable Codepad Tamper To Be Silent**

If this option has been enabled, a codepad tamper alarm will not operate the horn speaker, bell or the strobe outputs. If this option is not enabled, all three outputs will operate after a codepad tamper alarm has occurred.

Refer to "LOCATION 338" on page 101 to set the number of "Code Retries" before an alarm condition occurs. Enabling this option does not effect the operation of the communication dialler.

## LOCATION 667



Option	Description
1	Enable Data Output To Display Data For Area 1- Partitioned Systems Only
2	Enable External Modem Module For Alarm Link Operation
4	Enabled = AC Fail In 1 Hour, Disabled = AC Fail In 2 Minutes
8	Enable Zone Pulse Count Handover

Table 104: System Options 3

### 1 **Enable Data Output To Display Data For Area 1 - Partitioned Systems Only**

If this option has been enabled, the DATA terminal on the panel will be configured to transmit status information that is relevant only to Area 1. A "CP5 Area Addressable (CP500A)" codepad would be used in this instance.

If this option is not enabled, the "CP5 Master Partitioned (CP500P)" codepad will need to be used because information for all areas will be transmitted on the DATA terminal.

An advantage in using this option is that it allows you to configure a system into separate areas while still leaving the maximum number of programmable outputs available for other uses.

### 2 **Enable External Modem Module For Alarm Link**

If this option has been enabled, the control panel will use the external plug-in Modem Module (CC811) for remote programming via the Alarm Link Software (CC816). This option should only be enabled in situations where the telephone line is susceptible to noise.

If this option is not enabled, the control panel will use its own built in modem.

### 4 **Enabled = AC Fail In 1 Hour, Disabled = AC Fail In 2 Minutes**

If this option has been enabled, the MAINS indicator will begin to flash and an "AC Loss" signal will be transmitted to the base station receiver after the AC mains has been disconnected continuously for more than 60 minutes.

If this option is not enabled, the MAINS indicator will begin to flash and an "AC Loss" signal will be transmitted to the base station receiver after the AC mains power has been disconnected continuously for 2 minutes.

The MAINS indicator will cease to flash once the AC mains has been restored for more than two minutes.

### 8 **Enable Zone Pulse Count Handover**

If this option has been enabled, any zone pulse count readings will handover and accumulate to any zone that is triggered during the same arming cycle. Zone pulse count handover will only operate with zone pulse count options 8-15.

Refer to "Zone Pulse Count" on page 108 and "Zone Pulse Count Time" on page 109 for more information.

---

**Note:** From Software Version 1.37 onwards, 24 hour zones do not receive any handover pulses from other zones. 24 hour zones can handover pulses to other zones.

---

**LOCATION 668 - Software Version 1.10 Only**

<b>Option</b>	<b>Description</b>
<b>1</b>	Delay Siren Until Transmission Is Complete
<b>2</b>	Enable Resetting Of Sirens From All Areas - Partitioned Systems
<b>4</b>	Enable Auto Arming In AWAY Mode
<b>8</b>	Enable Auto Arming In STAY Mode 1

*Table 105: System Options 4 - Software Version 1.10 Only***1 Delay Siren Until Transmission Is Complete**

If this option has been enabled, the horn speaker, bell, strobe and EDMSAT outputs will not activate until the base station receiver has sent a "Kiss-Off" back to the control panel after the message has been transmitted. If multiple messages are transmitted, the sirens will activate after the last "Kiss-Off" has been sent.

If the transmission back to the base station was unsuccessful and a "Kiss-Off" was not received, the horn speaker, bell, strobe and EDMSAT outputs will activate after the third call attempt.

24 hour alarms are not effected by this option. The sirens will always activate immediately upon a 24 hour alarm.

**2 Enable Resetting Of Sirens From All Areas (Partitioned Systems Only)**

This option is only applicable when the control panel has been partitioned. If this option has been enabled, any valid user code from any area will be able to stop the horn speaker, strobe, bell and EDMSAT outputs from operating. This option does not allow a user code allocated from one area to disarm another area.

**4 Enable Auto Arming In AWAY Mode**

If automatic arming in AWAY Mode is preferred to automatic arming in STAY Mode 1, this option will need to be enabled. When the system has been partitioned, ALL areas will automatically arm in AWAY Mode.

**8 Enable Auto Arming In STAY Mode 1**

If automatic arming in STAY Mode 1 is preferred to automatic arming in the AWAY Mode, this option will need to be enabled. When the system has been partitioned, ALL areas will automatically arm in STAY Mode 1.

## LOCATION 668 - Software Version 1.20 Onwards



Option	Description
1	Delay Siren Until Transmission Is Complete
2	Enable Resetting Of Sirens From All Areas - Partitioned Systems
4	Ignore AC Mains Fail - <b>New From Software Version 1.30 Onwards</b>
8	Enable Auto Arming In STAY Mode 1

Table 106: System Options 4 - Software Version 1.20 - 1.40

**1 Delay Siren Until Transmission Is Complete**

If this option has been enabled, the horn speaker, bell, strobe and EDMSAT outputs will not activate until the base station receiver has sent a "Kiss-Off" back to the control panel after the message has been transmitted. If multiple messages are transmitted, the sirens will activate after the last "Kiss-Off" has been sent.

If the transmission back to the base station was unsuccessful and a "Kiss-Off" was not received, the horn speaker, bell, strobe and EDMSAT outputs will activate after the third call attempt.

24 hour alarms are not effected by this option. The sirens will always activate immediately upon a 24 hour alarm.

**2 Enable Resetting Of Sirens From All Areas (Partitioned Systems Only)**

This option is only applicable when the control panel has been partitioned. If this option has been enabled, any valid user code from any area will be able to stop the horn speaker, strobe, bell and EDMSAT outputs from operating. This option does not allow a user code allocated from one area to disarm another area.

**4 Ignore AC Mains Fail - New From Software Version 1.30**

If this option has been enabled, the MAINS indicator will not flash, nor will the codepad beep once every minute when the AC mains has been disconnected from the control panel. "Output Event Type - AC Fail" on page 128 will operate regardless of this option being set.

**8 Enable Auto Arming In STAY Mode 1**

If automatic arming in STAY Mode 1 is preferred to automatic arming in the AWAY Mode, this option will need to be enabled. When the system has been partitioned, ALL areas will automatically arm in STAY Mode 1.

**LOCATION 669 - Software Version 1.10 Only**

2

<b>Option</b>	<b>Description</b>
<b>1</b>	Enable Entry Guard Delay In STAY Mode
<b>2</b>	Enable Operation Of Sirens & Strobe In STAY Mode
<b>4</b>	Enable Code Only To Isolate
<b>8</b>	Enable Codepad Extinguish Mode

*Table 107: Consumer Options 1 - Software Version 1.10 Only***1 Enable Entry Guard Delay In STAY Mode**

If this option has been selected, all instant and handover zones will have an entry delay time as programmed in "LOCATION 638 - 639" on page 141 when armed in STAY Mode 1 or STAY Mode 2.

<b>Zone Type</b>	<b>Entry Time When In STAY Mode</b>
<b>Delay-1</b>	Delay-1
<b>Delay-2</b>	Delay-2
<b>Delay-3</b>	Delay-3
<b>Delay-4</b>	Delay-4
<b>24 Hour</b>	Nil
<b>Instant</b>	Entry Guard
<b>Handover</b>	Entry Guard

*Table 108: Entry Guard Delay Timer In STAY Mode***2 Enable Operation Of Sirens & Strobe In STAY Mode**

This option will need to be enabled if audible alarms are required when the system has been armed in STAY Mode 1 or STAY Mode 2.

**4 Code Only To Isolate**

If this option has been selected, the procedure for isolating zones changes from the method of standard isolating to one that requires the use of a valid user code. Refer to "Isolating Zones" on page 41 for further information.

**8 Enable Codepad Extinguish Mode**

If this option has been enabled, all indicators on the remote codepads will extinguish if a button is not pressed for 60 seconds. The indicators will illuminate when there is an alarm (except a silent alarm), when a button is pressed on the codepad, when the AC mains fail beeps, or if the entry timer has been activated.

## LOCATION 669 - Software Version 1.20 Onwards

2

Option	Description
1	Enable The STAY LED To Display Day Alarm ON/OFF Status
2	Enable Operation Of Sirens & Strobe In STAY Mode
4	Enable AUX LED To Display Telephone Line In Use On Partitioned Codepad
8	Enable Codepad Extinguish Mode

Table 109: Consumer Options 1 - Software Version 1.20 Onwards

**1 Enable STAY LED To Display Day Alarm ON/OFF Status**

If this option has been selected, the STAY indicator will be used to display when day alarm has been enabled. The STAY indicator will blink once every 3 seconds while day alarm is active.

**2 Enable Operation Of Sirens & Strobe In STAY Mode**

This option will need to be enabled if audible alarms are required when the system has been armed in STAY Mode 1 or STAY Mode 2.

**4 Enable AUX LED To Display Telephone Line In Use On Partitioned Codepad**

If this option has been enabled, the AUX indicator on a "CP5 Master Partitioned (CP500P)" codepad will illuminate when the control panel has seized the telephone line to transmit a report. The AUX indicator will extinguish once the telephone line has been released.

---

**Note:** If the control panel has been partitioned and zone 16 has been used, the AUX indicator will also be used to indicate when zone 16 has triggered into alarm.

---

**8 Enable Codepad Extinguish Mode**

If this option has been enabled, all indicators on the remote codepads will extinguish if a button is not pressed for 60 seconds. The indicators will illuminate when there is an alarm (except a silent alarm), when a button is pressed on the codepad, when the AC mains fail beeps, or if the entry timer has been activated.

**LOCATION 670**

2

<b>Option</b>	<b>Description</b>
<b>1</b>	Enable "User Code + 0 + AWAY" Function To Arm/Disarm All Areas
<b>2</b>	Enable Single Button Arming In AWAY, STAY Mode 1 and STAY Mode 2
<b>4</b>	Enable Single Button Disarming From STAY Mode 1 and STAY Mode 2
<b>8</b>	Enable Alarm Memory Reset On Disarm

*Table 110: Consumer Options 2***1 Enable "User Code + 0 + AWAY" Function To Arm/Disarm All Areas**

If this option has been selected, it will allow the user code holder to arm/disarm all areas at the same time without the need to enter the user code at each area codepad. Refer to "Master Code Functions" on page 50 and "User Code Function" on page 60 for more information.

If the user code holder arms all areas at the same time, if in "LOCATION 664" on page 151 has the option "First To Open/Last To Close Reporting" enabled, only a closing report for the last area will be reported.

If the user code holder disarms all areas at the same time, if in "LOCATION 664" on page 151 has the option "First To Open/Last To Close Reporting" enabled, only an opening report for the first area will be reported.

**2 Enable Single Button Arming In AWAY Mode, STAY Mode 1 and STAY Mode 2**

If this option has been selected, the hold down functions for arming in AWAY Mode, STAY Mode 1 and STAY Mode 2 will be functional. Refer to "Hold Down Functions" on page 61 for more information.

**4 Enable Single Button Disarming From STAY Mode 1 and STAY Mode 2**

This option will only operate when Option 2 in "LOCATION 670" on page 159 has been enabled. This option will enable hold down functions for disarming from STAY Mode 1 and STAY Mode 2. Refer to "Hold Down Functions" on page 61 for more information.

**8 Enable Alarm Memory Reset On Disarm**

This option allows the memory of alarm events to be cleared from the remote codepad when the system has been disarmed. If this option has not been enabled, the system will need to be armed and disarmed again to clear alarm memory from the remote codepad.

**DTMF Command Module Options****LOCATION 671**

<b>Option</b>	<b>Description</b>
<b>1</b>	Enable Access Into Installer's Programming Mode
<b>2</b>	Enable Access To Installer Code Functions
<b>4</b>	Enable Disarming Of System Via User Codes & Auxiliary Code Operations
<b>8</b>	Enable Access To Master Code Functions

*Table 111: DTMF Command Module Options*

The DTMF Command Module (CC886) must be fitted to the COMMAND MODULE socket on the *Solution-16* printed circuit board to enable access to any of these features via a touch tone telephone.

Caution must be exercised when using this feature as there is no visual feedback for confirmation.

Refer to "Operating The Control Panel Using The DTMF Command Module" on page 67 for more information.

**1 Enable Access Into Installer's Programming Mode**

If this option has been selected, access into Installer's Programming Mode will be allowed via any touch tone telephone. Programming of any location except for "LOCATION 900" may now take place.

**2 Enable Access To Installer Code Functions**

If this option has been selected, Installer Code Functions may be performed via any touch tone telephone.

**4 Enable Arming and Disarming Of System Via On/Off Codes and Auxiliary Code Operations**

If this option has been selected, the system can be armed and disarmed via any system user code and the operation and use of auxiliary code operations may be performed via any touch tone telephone.

**8 Enable Access To Master Code Functions**

If this option has been selected, access to Master Code Functions may be performed via any touch tone telephone. Refer to "Master Code Functions" on page 50 for more information.



**LOCATION 672 - Software Version 1.10 Only**

<b>Option</b>	<b>Description</b>
<b>0</b>	No Expansion Board Fitted
<b>1</b>	Eight Zone Expansion Board
<b>2</b>	Eight Channel Output Board
<b>4</b>	Momentary Keyswitch Input
<b>8</b>	Latching Keyswitch Input

*Table 112: Expansion Board Type - Software Version 1.10 Only*

This location enables the operation of an optional eight zone expansion board, eight channel output board or keyswitch operated inputs to arm or disarm the system.

The keyswitch operated inputs need to be connected to the JP5 terminals EXP and GND. Every time the system is armed or disarmed via the keyswitch operated input, user code 32 will be transmitted with the Open/Close reports.

Refer to "Figure 18: Connection For Momentary Or Latching Keyswitch" on page 197 for more information on wiring the JP5 pins for keyswitch operation.

---

**Note: Only one option can be selected from the options listed in this location.**

---

**0 No Expansion Board Fitted****1 Eight Zone Expansion Board Fitted**

If an eight zone expansion board is required to connect the additional zones (9-16), there is a choice of two different zone expansion boards that may be purchased.

The Eight Zone Expansion Board (CC883) can use variable resistor values enabling you to use one EOL resistor value for zones 1-8 and another EOL resistor value for zones 9-16.

The Eight Zone Expansion Board (CC885) can only be used with a fixed 3K3 EOL resistor value. This means that zones 1-8 can have any EOL resistor value from the available options in "LOCATION 339" on page 112 and only 3K3 EOL resistors for zones 9-16.

**2 Eight Channel Output Board Fitted**

The Eight Channel Output Board (CC884) allows the total number of programmable outputs to total 14. The eight channel output board provides terminals for programmable outputs 7-14.

---

**Note: A plug in Termination Board (CC882) is available for the following keyswitch input options.**

---

**4 Momentary Input For Arm and Disarm**

A momentary keyswitch may be used to arm and disarm the system in the AWAY Mode via the JP5 pins EXP and GND. If the system has been partitioned, ALL areas will arm and disarm in the AWAY Mode. If Option 8 in "LOCATION 665" on page 152 has been enabled, the horn speaker will give indication beeps when the system has been armed and disarmed. One beep indicates that the system has been disarmed, two beeps will indicate that the system has been armed in AWAY Mode.

**8 Latching Input For Arm and Disarm**

A toggle or latching keyswitch may be used to arm and disarm the system in the AWAY Mode via the JP5 pins EXP and GND. If the system has been partitioned, ALL areas will arm and disarm in the AWAY Mode. If Option 8 in "LOCATION 665" on page 152 has been enabled, the horn speaker will give indication beeps when the system has been armed and disarmed. One beep indicates that the system has been disarmed, two beeps will indicate that the system has been armed in AWAY Mode.

**Expansion Board Type**

**LOCATION 672 - Software Version 1.20 Onwards**



<b>Option</b>	<b>Description</b>	<b>Option</b>	<b>Description</b>
<b>0</b>	No Expansion Board Fitted	<b>8</b>	Momentary Disarm
<b>1</b>	Eight Zone Expansion Board Fitted	<b>9</b>	Momentary Arm Area 4
<b>2</b>	Eight Channel Output Board Fitted	<b>10</b>	Momentary Disarm Area 4
<b>3</b>	Momentary Input For Arm and Disarm	<b>11</b>	Momentary Arm/Disarm Area 4
<b>4</b>	Latching Input For Arm and Disarm	<b>12</b>	Latching Arm/Disarm Area 4
<b>5</b>	Momentary Arm In AWAY Mode		
<b>6</b>	Momentary Arm In STAY Mode 1		
<b>7</b>	Momentary Arm In STAY Mode 2		

*Table 113: Expansion Board Type - Software Version 1.20 Onwards*

This location enables the operation of an optional eight zone expansion board, eight channel output board or a number of different options for keyswitch operated inputs to arm or disarm the system.

The keyswitch operated inputs need to be connected to the JP5 terminals EXP and GND. Every time the system is armed or disarmed via the keyswitch operated input, user code 32 will be transmitted with the Open/Close reports.

Refer to "Figure 18: Connection For Momentary Or Latching Keyswitch" on page 197 for more information on wiring the JP5 pins for keyswitch operation.

---

**Note: Only one option can be selected from the options listed in this location.**

---

**0 No Expansion Board Fitted**

**1 Eight Zone Expansion Board Fitted**

If an eight zone expansion board is required to connect the additional zones (9-16), there is a choice of two different zone expansion boards that may be purchased.

The Eight Zone Expansion Board (CC883) can use variable resistor values enabling you to use one EOL resistor value for zones 1-8 and another EOL resistor value for zones 9-16.

The Eight Zone Expansion Board (CC885) can only be used with a fixed 3K3 EOL resistor value. This means that zones 1-8 can have any EOL resistor value from the available options in "LOCATION 339" on page 112 and only 3K3 EOL resistors for zones 9-16.

**2 Eight Channel Output Board Fitted**

The Eight Channel Output Board (CC884) allows the total number of programmable outputs to total 14. The eight channel output board provides terminals for programmable outputs 7-14.

---

**Note: A plug in Termination Board (CC882) is available for the following keyswitch input options.**

---

**3 Momentary Input For Arm and Disarm**

A momentary keyswitch may be used to arm and disarm the system in the AWAY Mode via the JP5 pins EXP and GND. If the system has been partitioned, ALL areas will arm and disarm in the AWAY Mode. If Option 8 in "LOCATION 665" on page 152 has been enabled, the horn speaker will give indication beeps when the system has been armed and disarmed. One beep indicates that the system has been disarmed, two beeps will indicate that the system has been armed in AWAY Mode.

#### **4 Latching Input For Arm and Disarm**

A toggle or latching keyswitch may be used to arm and disarm the system in the AWAY Mode via the JP5 pins EXP and GND. If the system has been partitioned, ALL areas will arm and disarm in the AWAY Mode. If Option 8 in "LOCATION 665" on page 152 has been enabled, the horn speaker will give indication beeps when the system has been armed and disarmed. One beep indicates that the system has been disarmed, two beeps will indicate that the system has been armed in AWAY Mode.

#### **5 Momentary Arm In AWAY Mode**

A momentary keyswitch may be used to arm the system in the AWAY Mode via the JP5 pins EXP and GND. If the system has been partitioned, ALL areas will arm in the AWAY Mode. Horn speaker indication beeps do not function for the option type.

#### **6 Momentary Arm In STAY Mode 1**

A momentary keyswitch may be used to arm the system in the STAY Mode 1 via the JP5 pins EXP and GND. If the system has been partitioned, this option will not operate. Horn speaker indication beeps do not function for the option type.

#### **7 Momentary Arm In STAY Mode 2**

A momentary keyswitch may be used to arm the system in the STAY Mode 2 via the JP5 pins EXP and GND. If the system has been partitioned, this option will not operate. Horn speaker indication beeps do not function for the option type.

#### **8 Momentary Disarm Only**

A momentary keyswitch may be used to disarm the system from AWAY Mode, STAY Mode 1 and STAY Mode 2 via the JP5 pins EXP and GND. If the system has been partitioned, ALL areas will disarm. Horn speaker indication beeps do not function for the option type.

#### **9 Momentary Arm Area 4**

A momentary keyswitch may be used to arm only Area 4 when the system has been partitioned via the JP5 pins EXP and GND. Horn speaker indication beeps do not function for the option type.

#### **10 Momentary Disarm Area 4**

A momentary keyswitch may be used to disarm only Area 4 when the system has been partitioned via the JP5 pins EXP and GND. Horn speaker indication beeps do not function for the option type.

#### **11 Momentary Arm/Disarm Area 4**

A momentary keyswitch may be used to arm and disarm Area 4 via the JP5 pins EXP and GND when the system has been partitioned. If Option 8 in "LOCATION 665" on page 152 has been enabled, the horn speaker will give identification beeps when the system has been armed and disarmed. One beep indicates that Area 4 has been disarmed, two beeps will indicate that Area 4 has been armed in AWAY Mode.

#### **12 Latching Arm/Disarm Area 4**

A toggle or latching keyswitch may be used to arm and disarm Area 4 via the JP5 pins EXP and GND when the system has been partitioned. If Option 8 in "LOCATION 665" on page 152 has been enabled, the horn speaker will give identification beeps when the system has been armed and disarmed. One beep indicates that Area 4 has been disarmed, two beeps will indicate that Area 4 has been armed in AWAY Mode.

**Telephone Line Fault Options****LOCATION 673**

0

<b>Option</b>	<b>Description</b>
<b>1</b>	Operate The FAULT Indicator When Telephone Line Fails
<b>2</b>	Sound Speaker, Bell and Strobe When System Is Armed
<b>4</b>	Sound Speaker, Bell and Strobe When System Is Disarmed
<b>8</b>	Reserved

*Table 114: Telephone Line Fault Options*

The optional Telephone Line Fault Module (CC887) may be connected to the LINE FAULT MODULE socket located towards the top right hand corner of the control panel to monitor the telephone line.

If the telephone line has been cut or disconnected for more than forty seconds, the telephone line fault module will recognise this and the FAULT indicator will illuminate on the codepad. The FAULT indicator will extinguish once the telephone line has been restored for more than forty seconds.

---

**Note:** Option 2 and 4 will not operate unless option 1 has been enabled. If option 1 has been enabled and no telephone line fault module has been connected to the control panel, a FAULT indicator will illuminate and "LOCATION 673" will need to be programmed back to the factory default value to clear the fault.

---

**1 Operate The FAULT Indicator When Telephone Line Fails**

The FAULT indicator will flash and the codepad buzzer will beep once every minute if the Telephone Line Fault Module (CC887) detects that the telephone line has been disconnected. Refer to "Fault Descriptions" on page 42 for further information on telephone line fault.

**2 Sound Speaker, Bell and Strobe When The System Is Armed**

Option 1 in "LOCATION 673" will need to be enabled for this option to operate. If the Telephone Line Fault Module (CC873) detects that the telephone line has been disconnected when the system is armed in AWAY Mode, STAY Mode 1 or STAY Mode 2, the horn speaker, bell, strobe and EDMSAT outputs will operate.

If the control panel has been partitioned, this option will operate when any area has been armed in AWAY Mode or STAY Mode 1.

**4 Sound Speaker, Bell and Strobe When The System Is Disarmed**

Option 1 in "LOCATION 673" will need to be enabled for this option to operate. If the Telephone Line Fault Module (CC887) detects that the telephone line has been disconnected when the system is disarmed, the horn speaker, bell, strobe and EDMSAT outputs will operate.

If the system has been partitioned, this option will operate only when ALL areas have been disarmed.

**8 Reserved**

---

**Note:** If ALL three options have been enabled, the horn speaker, bell, strobe and EDMSAT outputs will operate in either armed or disarmed state.

---

If a serial printer has been connected to output 3, the message "Phone Line Failure" will be reported when the telephone line has been disconnected. Once the telephone line has been restored for more than 40 seconds continuously, the message "Phone Line Restore" will be reported. The printer will log the actual date and time that the report had occurred.

**Safecom Options****LOCATION 896**

(Safecom Only)

6

<b>Option</b>	<b>Description</b>
<b>1</b>	Disable – Safecom Communication Reporting
<b>2</b>	Enable – Enable Remote Arming Via ST1000 Base
<b>4</b>	Enable – Enable Remote Disarming Via ST1000 Base
<b>8</b>	Reserved

**1 Disable – Safecom Communications Reporting**

Programming this option will disable safecom communication control panel will only report via the telephone line to the base station.

**2 Enable – Remote Arming Via ST1000 Base**

If this option has been enabled, the control panel can be armed via the Base Station on the safecom terminal.

**4 Enable – Remote Disarming Via ST1000 Base**

If this option has been enabled, The control panel can be disarmed via the Base Station on the safecom terminal.

**8 Reserved**

**Note:** If Option 1 is Programmed and Dialler is Enabled in location 663 the Solution 16 will report via the telephone line.

**System Options 5****LOCATION 897**

0

<b>Option</b>	<b>Description</b>
<b>1</b>	Enable - Send "Test" Report After Siren Reset
<b>2</b>	Enable Control Panel To Power Up In Disarmed State
<b>4</b>	Enable Internal Crystal To Keep Time
<b>8</b>	Reserved

**1 Enable - Send "Test" Report After Siren Reset**

Enabling this option will force the control panel to transmit a test report after the siren has reset. This can be used to indicate to the monitoring station that the control panel has not been tampered with during the alarm period.

**2 Enable Control Panel To Power Up In Disarmed State**

If this option has been enabled, the control panel will power up in the disarmed state once the battery and AC mains have been reconnected once the system has been powered down. EDM does not recommend this feature.

**4 Enable Internal Crystal To Keep Time (New - Software Version 1.40 Onwards)**

If this option has been enabled, it will force the control panel not to use the mains frequency as a time base to keep time. The control panel will use the internal crystal (XTAL) to keep track of time. This option is useful in countries that do not have a constant mains frequency.

## LOCATION 898 - New From Software Version 1.33 Onwards

3

Option	Description
1	Enable Busy Tone Detection For Domestic Dialling
2	Enable "Kiss-Off" Detection For Domestic Dialling
4	Extend Acknowledge Tone Detection From 30 - 60 Seconds
8	If Battery Fails, Enable Dynamic Battery Test Only On Arming (New - Software Version 1.35)

Table 115: System Options 6

**1 Enable Busy Tone Detection For Domestic Dialling**

This option is valid only when the control panel has been set up for "Domestic Dialling Format". When this option has been enabled, the dialling algorithm will check for a busy tone. This is particularly important in that the control panel will only make 3 valid call attempts. A valid attempt is signified by the absence of a busy tone.

**2 Enable "Kiss-Off" Detection For Domestic Dialling**

This option is valid only when the control panel has been programmed for domestic dialling format. A defaulted control panel will seize the telephone line and commence reporting an alarm condition. During its report, the control panel looks for a tone either from a hand held phone controller, or, if a DTMF Command Module is not fitted, the  button on a touch tone telephone. Once the control panel has received this tone, the control panel terminates the report and hangs up the telephone line, otherwise the control panel will keep dialling until it reaches its maximum call attempts.

With this option disabled, the control panel will not look for the "Kiss-Off" tone and will therefore keep reporting until the unit is either disarmed, or the maximum call count has been reached.

**4 Extend Acknowledge Tone Detection From 30 - 60 Seconds**

The control panel after dialling the monitoring station will wait approximately 30 seconds for receipt of a valid handshake tone. The handshake tone indicates to the control panel that it has reached the monitoring station and can now transmit its messages. Enabling this option will extend the wait time from 30 seconds to 1 minute.

**8 If Battery Has Failed, Enable Dynamic Battery Test Only On Arming (New - Software Version 1.35)**

The control panel will execute a "Dynamic Battery Test" every four hours while the AC mains is present. During this battery test, the battery is loaded and its voltage monitored over a 3 second period. If the battery voltage drops below approximately 10.5V, a low battery condition is generated and reported accordingly. The control panel will continue to test the battery even when the battery has failed a previous load test.

Enabling this option will cancel the 4 hourly dynamic battery tests if there is a current low battery condition. The control panel will still however test the battery every time the system has been armed in AWAY Mode, STAY Mode 1 and STAY Mode 2.

## LOCATION 899

9

Option	Carrier Sync Time	Option	Carrier Sync Time
1	100 ms	9	900 ms
2	200 ms	10	1 Second
3	300 ms	11	1.1 Seconds
4	400 ms	12	1.2 Seconds
5	500 ms	13	1.3 Seconds
6	600 ms	14	1.4 Seconds
7	700 ms	15	1.5 Seconds
8	800 ms		

Table 116: Carrier Sync Time

The micro chip that operates the *Solution-16* control panel simulates a 300 baud modem.

Generally, a telecommunications interface (Phone Line Interface) incorporates a 2 wire to a 4 wire conversion so that the information that you transmit is separate to the information that you receive. However, in the *Solution-16* control panel, there is no 2 wire to 4 wire conversion. What is transmitted is also received (This is like talking on a phone handset and hearing yourself talk).

When two modems are connected, they exchange tones with each other that allows them to communicate with one another. The sync tone a modem sends to another modem is called a carrier. Generally, to remain in sync, each modem must receive the other modems carrier. If a carrier has been lost, some modems initiate an error correction algorithm.

Because the *Solution-16* control panel does not have a 2 wire to 4 wire converter, the control panel must stop sending its carrier to the remote modem when it receives data. When it is time to send data again, it reapplies the carrier before sending data. Some modems unfortunately do not synchronise as quickly as other modems. Remember a modem must be synchronised before receiving data. The time it takes a modem to sync varies from modem to modem. Some modems may only want a carrier for 100 ms while others may require a carrier for 900 ms.

“LOCATION 899” specifies in units of 100 ms, how long the *Solution-16* control panel should apply a carrier before commencing data transmissions.





# Partitioning

---

## **This Section Includes The Following:**

- *Partitioning*
- *Master Partitioned Codepad Indicators*
- *Operating Codepads In Partitioning*
- *Securitel and Partitioning*
- *Programming*
- *Open/Close Reports*
- *Subscriber ID Number*
- *Zone Allocations*
- *User Code Allocations*
- *Setting Up and Programming Codepads For Partitioning*
- *Codepad Connections For Partitioning*

## Partitioning

Partitioning allows a single control panel to act as if it were four different control panels. There is a "CP5 Master Partitioned (CP500P)" codepad that has indicators to show the status of all areas individually.

If you wish to allocate each area a separate codepad, the "CP5 Area Addressable (CP500A)" codepad must be used. This will give the user the impression that they are the only operator of the system.

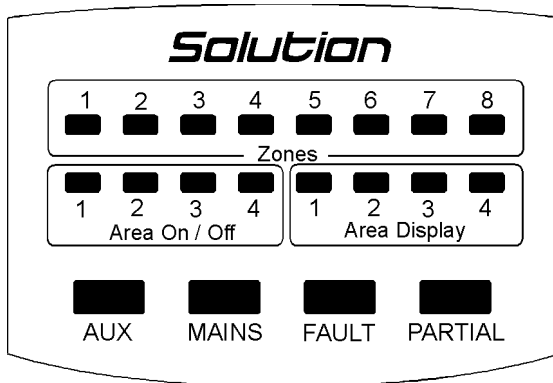

Figure 5: "CP5 Master Partitioned (CP500P)" Codepad

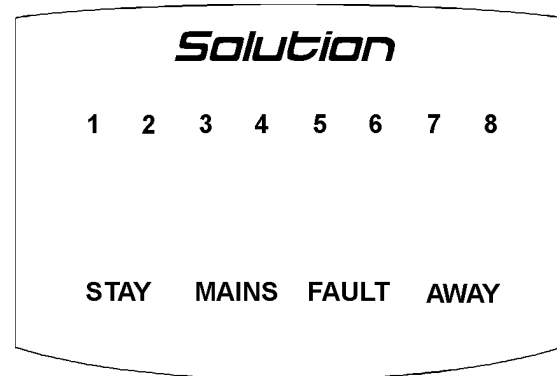

Figure 6: "CP5 Area Addressable (CP500A)" Codepad

If the control panel has been partitioned, you can have a maximum of four areas. Each area can have up to a maximum of 8 zones.

Zones may be shared between areas to act as common zones. Zone 16 cannot be allocated to an area and will be indicated when triggered by the AUX indicator on the "CP5 Master Partitioned (CP500P)" codepad or the FAULT indicator on "CP5 Area Addressable (CP500A)" codepad. It would then be recommended to program Zone 16 to operate as a 24 hour zone and common to all areas.

## Master Partitioned Codepad Indicators

The indicators on a "CP5 Master Partitioned (CP500P)" codepad are configured in to four groups. Following is a description of what the indicators show;

### 1 Zone Indicators

Zone indicators (1-8) display the status of each zone. These zones belong to the area that has the AREA DISPLAY indicator illuminated (ie. If a ZONE indicator is illuminated, that zone is unsealed and if the ZONE indicator is not illuminated, that zone is sealed).

### 2 Areas On/Off Indicators

The group of four AREA DISPLAY indicators show the status of each area (ie. If an indicator is illuminated, that area is armed and if the indicator is not illuminated, that area is disarmed).

### 3 Area Display Indicators

A group of four AREA DISPLAY indicators show what area the zones belong to that are currently being displayed.

### 4 Status Indicators

A group of four indicators show the following:

**AUX Indicator**

This indicator will display the status of Zone 16 when the control panel has been partitioned. If Option 4 has been enabled in "LOCATION 669" the AUX indicator may be used to display when the control panel is using the telephone line.

**MAINS Indicator**

This indicator displays the status of the AC mains supply (ie. If the MAINS indicator is illuminated, the AC mains is normal and if the indicator is flashing, the AC mains has been disconnected).

**FAULT Indicator**

This indicator displays the status of the systems fault register (ie. If the indicator is flashing, the system has detected a fault that has not yet been acknowledged. If the indicator is illuminated, the fault has been acknowledged and if the indicator is not illuminated, the system has no system faults).

**PARTIAL Indicator**

The partial indicator displays whether an area is armed in STAY Mode 1 or STAY Mode 2. (ie. If the PARTIAL indicator is illuminated, an area is armed in either STAY Mode 1 or STAY Mode 2 and if the PARTIAL indicator is not illuminated, no areas are armed in STAY Mode 1 or STAY Mode 2).

Whilst isolating zones, the PARTIAL indicator flashes to indicate that you are in the isolate mode.

This PARTIAL indicator will flash in conjunction with the AUX indicator to indicate successful entry into any programming mode. For example, this will occur when entering the Installer's Programming Mode.

**Operating Codepads In Partitioning****Operating From A "CP5 Area Addressable (CP500A)" Codepad**

If you have a partitioned system with "CP5 Area Addressable (CP500A)" codepads installed, the operating procedure is exactly the same as described throughout this manual. Refer to "Hold Down Functions" on page 61 to determine which area a particular codepad belongs.



**Operating From A "CP5 Master Partitioned (CP500P)" Codepad**

If you have a partitioned system with a "CP5 Master Partitioned (CP500P)" codepad installed, the operating procedure is the same as described throughout this manual with one exception. All operations are relative to the area whose AREA DISPLAY indicator is illuminated at the time.

**Example**

If the AREA DISPLAY indicator number 2 is illuminated, all operations performed will only effect Area 2. To perform any operations in another area, you will have to move the AREA DISPLAY indicator to the desired area.

**To Move From One Area To The Next**

1. Press the  button.  
The area display indicator will move to the next area.
2. Press the  button again.  
The area display indicator will move to the next area.

**Securitel and Partitioning**

The EDMSTU was not designed to send individual Open/Close reports for each area via the Securitel Network. It will however send first to open and last to close reports if Option 2 in "LOCATION 664" has been enabled. Refer to "Table 31: Securitel Reporting Messages" on page 77 for the list of reports that can be transmitted via the Securitel Network.

## **Questions To Be Considered When Partitioning**

When programming a *Solution-16* control panel for partitioning there are a few steps that need to be considered.

1. How many areas do you need ?
2. What zones will be common to what areas ?
3. Does each area need to send individual open and close reports ? or
4. Will first to open and last to close reports be sufficient ?
5. Is your base station running Sims 1 or Sims 2 software ?
6. If the base station is running Sims 1 software and you want to send individual open and close reports for each area, you will need to allocate a separate Subscriber ID Number for each area. Sims 2 software will accept multiple open and close reports on the same Subscriber ID Number ?
7. Does each area need its own different entry delay time ?
8. Does each area need its own individual codepad ?
9. Does each area need its own individual siren and strobe ?
10. What areas are each user allowed access to ?

## Open/Close Reports

The following options are related to Open/Close reports. You can select one, two or all three options to suit your application.

### Dialler Options 2

#### LOCATION 664



Option	Description
1	Send Open/Close Reports Only If A Previous Alarm Has Occurred
2	Enable First To Open/Last To Close Reporting When Partitioned
4	Send Open/Close Reports When Armed In STAY Mode 1 & 2
8	Enable Answering Machine Bypass Only When System Is Armed (New - Software Version 1.31 Onwards)

Table 117: Dialler Options 2

#### 1 **Send Open/Close Report Only If A Previous Alarm Has Occurred**

This option requires Open/Close Reports in "LOCATION 504 - 505" programmed on page 120 for it to be effective.

An open report will be transmitted to the base station receiver when the system has been disarmed after an alarm has occurred. When the system has been armed, a closing report will be transmitted. This feature can also be used in conjunction with the Patrolman Code. Refer to "Patrolman Code" on page 99 for more information.

If the system has been partitioned, an Open/Close report will only be transmitted on the area that the alarm had occurred.

---

**Note:** If the system has been disarmed when an alarm has occurred, only a closing report will be transmitted when the system has been armed.

---

#### 2 **Enable First To Open, Last To Close Reporting When Partitioned**

This option needs to be enabled if only one Open/Close report is required when the system has been partitioned. Rather than having individual Open/Close reports for each area, a closing report will be transmitted only when ALL areas have been armed and an opening report will be transmitted as soon as one area has been disarmed.

The reports will be transmitted on the Subscriber ID Number allocated to that particular area. Subscriber ID Numbers and Open/Close reports must be programmed for all areas.

#### 4 **Send Open/Close Reports When In STAY Mode 1 and STAY Mode 2**

If open and close reports are required when the system is armed in STAY Mode 1 or STAY Mode 2, this option will need to be enabled.

#### 8 **Enable Answering Machine Bypass Only When System Is Armed (New - Software Version 1.31 Onwards)**

This option needs to be enabled if the answering machine bypass feature is required to operate only when the system has been armed. When the system has been disarmed, the control panel will not answer any incoming calls. This option is beneficial in high telephone traffic installations where the control panel could answer an incoming call.

**Open/Close Codes For Area 1**

LOCATION 504-505

8 9

<i>Location</i>	<i>Description</i>
504	Opening Report Code For Area 1
505	Closing Report Code For Area 1

*Table 118: Area 1 Open/Close Report Locations***Open/Close Codes For Area 2**

LOCATION 674 - 675

0 0

<i>Location</i>	<i>Description</i>
674	Opening Report Code For Area 2
675	Closing Report Code For Area 2

*Table 119: Area 2 Open/Close Report Locations***Open/Close Codes For Area 3**

LOCATION 676 - 677

0 0

<i>Location</i>	<i>Description</i>
676	Opening Report Code For Area 3
677	Closing Report Code For Area 3

*Table 120: Area 3 Open/Close Report Locations***Open/Close Codes For Area 4**

LOCATION 678 - 679

0 0

<i>Location</i>	<i>Description</i>
678	Opening Report Code For Area 4
679	Closing Report Code For Area 4

*Table 121: Area 4 Open/Close Report Locations*

**Subscriber ID Number For Area 1**

LOCATION 052 - 055

0 0 0 0

<b>Location</b>	<b>Description</b>
52	Area 1 Subscriber ID Number (Thousands Digit)
53	Area 1 Subscriber ID Number (Hundreds Digit)
54	Area 1 Subscriber ID Number (Tens Digit)
55	Area 1 Subscriber ID Number (Units Digit)

*Table 122: Area 1 Subscriber ID Number Locations***Subscriber ID Number For Area 2**

LOCATION 680 - 683

0 0 0 0

<b>Location</b>	<b>Description</b>
680	Area 2 Subscriber ID Number (Thousands Digit)
681	Area 2 Subscriber ID Number (Hundreds Digit)
682	Area 2 Subscriber ID Number (Tens Digit)
683	Area 2 Subscriber ID Number (Units Digit)

*Table 123: Area 2 Subscriber ID Number Locations***Subscriber ID Number For Area 3**

LOCATION 684 - 687

0 0 0 0

<b>Location</b>	<b>Description</b>
684	Area 3 Subscriber ID Number (Thousands Digit)
685	Area 3 Subscriber ID Number (Hundreds Digit)
686	Area 3 Subscriber ID Number (Tens Digit)
687	Area 3 Subscriber ID Number (Units Digit)

*Table 124: Area 3 Subscriber ID Number Locations***Subscriber ID Number For Area 4**

LOCATION 688 - 691

0 0 0 0

<b>Location</b>	<b>Description</b>
688	Area 4 Subscriber ID Number (Thousands Digit)
689	Area 4 Subscriber ID Number (Hundreds Digit)
690	Area 4 Subscriber ID Number (Tens Digit)
691	Area 4 Subscriber ID Number (Units Digit)

*Table 125: Area 4 Subscriber ID Number Locations*

## Zone Allocations

Each area can have up to eight zones allocated to it. The eight locations for each area represent ZONE indicators one to eight on the remote codepad. Any of the zone inputs (1-15) can be mapped to any area to appear as any zone on the remote codepad (ie. Any zone from 1-15 can be common to as many areas as required).

Common zones report to the base station receiver on group zero. Zones that are specific to one area will report on the corresponding group number.

Zone 16 is common to all areas and cannot be mapped to an individual area. It is ideally suited as a 24 hour burglary or fire zone. If zone 16 has been programmed as an instant zone, it will become active as soon as any area has been armed. When zone 16 has triggered, the AUX indicator on a "CP5 Master Partitioned (CP500P)" codepad will illuminate, or if an "CP5 Area Addressable (CP500A)" codepad has been used, zone 16 will be indicated by the FAULT indicator.

### Zone Allocations For Area 1

LOCATION 692 - 699



Location	Description
692	Area 1 - Zone 1 Indicator
693	Area 1 - Zone 2 Indicator
694	Area 1 - Zone 3 Indicator
695	Area 1 - Zone 4 Indicator
696	Area 1 - Zone 5 Indicator
697	Area 1 - Zone 6 Indicator
698	Area 1 - Zone 7 Indicator
699	Area 1 - Zone 8 Indicator

Table 126: Area 1 Zone Allocations

### Zone Allocations For Area 2

LOCATION 700 - 707



Location	Description
700	Area 2 - Zone 1 Indicator
701	Area 2 - Zone 2 Indicator
702	Area 2 - Zone 3 Indicator
703	Area 2 - Zone 4 Indicator
704	Area 2 - Zone 5 Indicator
705	Area 2 - Zone 6 Indicator
706	Area 2 - Zone 7 Indicator
707	Area 2 - Zone 8 Indicator

Table 127: Area 2 Zone Allocations



**Zone Allocations For Area 3**

LOCATION 708 - 715

0 0 0 0 0 0 0 0

Location	Description
708	Area 3 - Zone 1 Indicator
709	Area 3 - Zone 2 Indicator
710	Area 3 - Zone 3 Indicator
711	Area 3 - Zone 4 Indicator
712	Area 3 - Zone 5 Indicator
713	Area 3 - Zone 6 Indicator
714	Area 3 - Zone 7 Indicator
715	Area 3 - Zone 8 Indicator

Table 128: Area 3 Zone Allocations

**Zone Allocations For Area 4**

LOCATION 716 - 723

0 0 0 0 0 0 0 0

Location	Description
716	Area 4 - Zone 1 Indicator
717	Area 4 - Zone 2 Indicator
718	Area 4 - Zone 3 Indicator
719	Area 4 - Zone 4 Indicator
720	Area 4 - Zone 5 Indicator
721	Area 4 - Zone 6 Indicator
722	Area 4 - Zone 7 Indicator
723	Area 4 - Zone 8 Indicator

Table 129: Area 4 Zone Allocations

**Note:** Any zone that is common to more than one area will report to the base station receiver on group zero.

**Example**

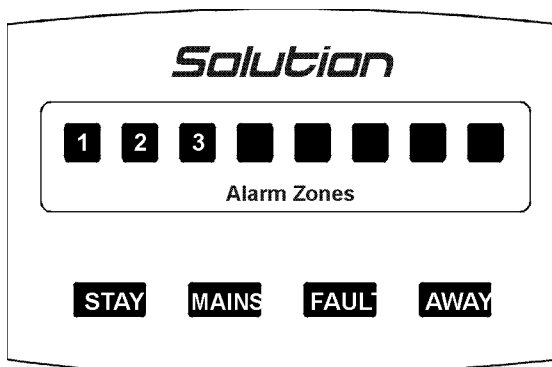

Figure 7: "CP5 Area Addressable (CP500A)" Codepad

**Area 1 Zone Allocations**

LOCATION 692 - 699

7 8 9 0 0 0 0 0

In this example, zones 7, 8 and 9 have been mapped to Area 1 to appear as zones 1, 2 and 3.

Programming the same zone number into more than one area indicates that the zone will operate as a common zone.

For example, if zone 2 is allocated to Area 1 and Area 3, zone 2 will then become a common zone to both Areas 1 and Area 3. Zone 2 will not trigger unless both Area 1 and Area 3 have been armed. Any number of zones can be mapped to any combination of the four areas to act as common zones.

## User Code Allocations

"LOCATIONS 724 - 755" are provided for assigning each user code to an area or multiple area when the control panel has been partitioned. A number between 1-15 is required to be entered into each of these locations to assign each user code holder to the areas they require to operate. Multiple user codes can be allocated to the same areas.

Select the required areas that the user code holder is to operate and then add the option values together from "Table 130: User Code Allocations" below (eg. If the user code is allocated to operate all four areas, program a 15 (ie. 1 + 2 + 4 + 8 = 15) into the required location relevant to their user code allocation. If the user code is allocated only to Area 1 and Area 3 (ie. 1 + 4 = 5), program their user code allocation as 5).

Option	Allocated Areas
1	Area 1
2	Area 2
4	Area 3
8	Area 4

Table 130: User Code Allocations

Location 724 <b>User Code 1</b> <input type="text" value="0"/>	Location 725 <b>User Code 2</b> <input type="text" value="0"/>	Location 726 <b>User Code 3</b> <input type="text" value="0"/>	Location 727 <b>User Code 4</b> <input type="text" value="0"/>
Location 728 <b>User Code 5</b> <input type="text" value="0"/>	Location 729 <b>User Code 6</b> <input type="text" value="0"/>	Location 730 <b>User Code 7</b> <input type="text" value="0"/>	Location 731 <b>User Code 8</b> <input type="text" value="0"/>
Location 732 <b>User Code 9</b> <input type="text" value="0"/>	Location 733 <b>User Code 10</b> <input type="text" value="0"/>	Location 734 <b>User Code 11</b> <input type="text" value="0"/>	Location 735 <b>User Code 12</b> <input type="text" value="0"/>
Location 736 <b>User Code 13</b> <input type="text" value="0"/>	Location 737 <b>User Code 14</b> <input type="text" value="0"/>	Location 738 <b>User Code 15</b> <input type="text" value="0"/>	Location 739 <b>User Code 16</b> <input type="text" value="0"/>
Location 740 <b>User Code 17</b> <input type="text" value="0"/>	Location 741 <b>User Code 18</b> <input type="text" value="0"/>	Location 742 <b>User Code 19</b> <input type="text" value="0"/>	Location 743 <b>User Code 20</b> <input type="text" value="0"/>
Location 744 <b>User Code 21</b> <input type="text" value="0"/>	Location 745 <b>User Code 22</b> <input type="text" value="0"/>	Location 746 <b>User Code 23</b> <input type="text" value="0"/>	Location 747 <b>User Code 24</b> <input type="text" value="0"/>
Location 748 <b>User Code 25</b> <input type="text" value="0"/>	Location 748 <b>User Code 26</b> <input type="text" value="0"/>	Location 750 <b>User Code 27</b> <input type="text" value="0"/>	Location 751 <b>User Code 28</b> <input type="text" value="0"/>
Location 752 <b>User Code 29</b> <input type="text" value="0"/>	Location 753 <b>User Code 30</b> <input type="text" value="0"/>	Location 754 <b>User Code 31</b> <input type="text" value="0"/>	Location 755 <b>User Code 32</b> <input type="text" value="0"/>

Refer to "User Codes" on page 98 for further programming information of the actual codes.

## Setting Up and Programming Codepads For Partitioning

To connect area addressable codepads to a system that has been partitioned, a few steps will need to be taken for the codepads to operate correctly.

### Setting Up The Master Partitioned Codepad As The Main Codepad

If you are using the “CP5 Master Partitioned (CP500P)” codepad as the main codepad of the partitioned system, you will need to connect the codepad to the main codepad terminals (GND, +12V, CLK and DATA). There are three DIP Switches which ALL should be in the ON position.

### Setting Up An Area 1 Codepad As The Main Codepad

If you are not using a “CP5 Master Partitioned (CP500P)” codepad as the main codepad of the partitioned system, you will need to connect the Area 1 codepad to the main codepad terminals (GND, +12V, CLK and DATA). In addition to setting up the Area 1 codepad, you will need to set the DIP switch 1 on the back of the codepad into the ON position and enable Option 1 in “LOCATION 667” on page 154.

### Setting Up An Area 1 Codepad

If you wish to have a separate area codepad only for Area 1 when using the “CP5 Master Partitioned (CP500P)” codepad as the main codepad, you will need to connect the Area 1 codepad to the main codepad terminals (GND, +12V & CLK) with the DATA terminal to be connected to one of the programmable outputs programmed as “6,0 - Area 1 Codepad Data”. DIP switch 1 on the back of the Area 1 codepad will need to be in the on position.

### Setting Up An Area 2 Codepad

If you wish to have a separate area codepad only for Area 2 when using the “CP5 Master Partitioned (CP500P)” codepad as the main codepad, you will need to connect the Area 2 codepad to the main codepad terminals (GND, +12V & CLK) with the DATA terminal to be connected to one of the programmable outputs programmed as “6,1 - Area 2 Codepad Data”. DIP switch 2 on the back of the Area 2 codepad will need to be in the on position.

### Setting Up An Area 3 Codepad

If you wish to have a separate area codepad only for Area 3 when using the “CP5 Master Partitioned (CP500P)” codepad as the main codepad, you will need to connect the Area 3 codepad to the main codepad terminals (GND, +12V & CLK) with the DATA terminal to be connected to one of the programmable outputs programmed as “6,2 - Area 3 Codepad Data”. DIP switch 1 and 2 on the back of the Area 3 codepad will need to be in the on position.

### Setting Up An Area 4 Codepad

If you wish to have a separate area codepad only for Area 4 when using the “CP5 Master Partitioned (CP500P)” codepad as the main codepad, you will need to connect the Area 4 codepad to the main codepad terminals (GND, +12V & CLK) with the DATA terminal to be connected to one of the programmable outputs programmed as “6,3 - Area 4 Codepad Data”. DIP switch 3 on the back of the Area 4 codepad will need to be in the on position.

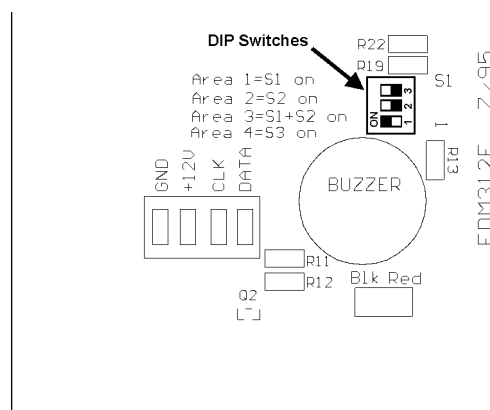

Figure 8:D\AREA Codepad DIP Switch Settings

### Codepad Connections For Partitioning

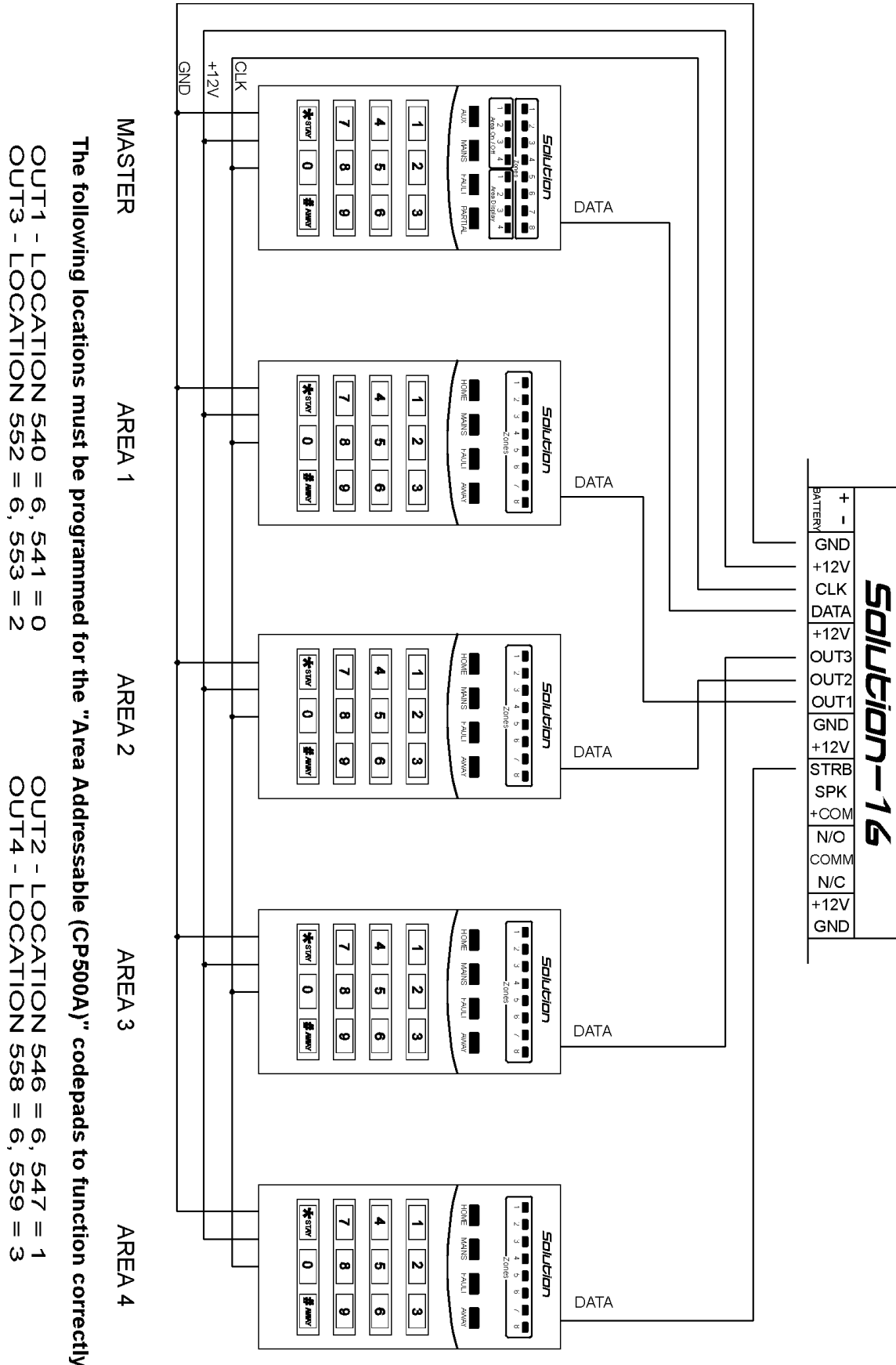

Figure 9: Connections For "CP5 Master Partitioned (CP500P)" Codepad and "CP5 Area Addressable (CP500A)" Codepads

The following locations must be programmed for the "Area Addressable (CP500A)" codepads to function correctly.

LOCATION 667, Enable Option 1 - Main Codepad To Display Data For Area 1  
 OUT1 - LOCATION 540 = 6, 541 = 1,      OUT2 - LOCATION 546 = 6, 547 = 2  
 OUT3 - LOCATION 552 = 6, 553 = 3

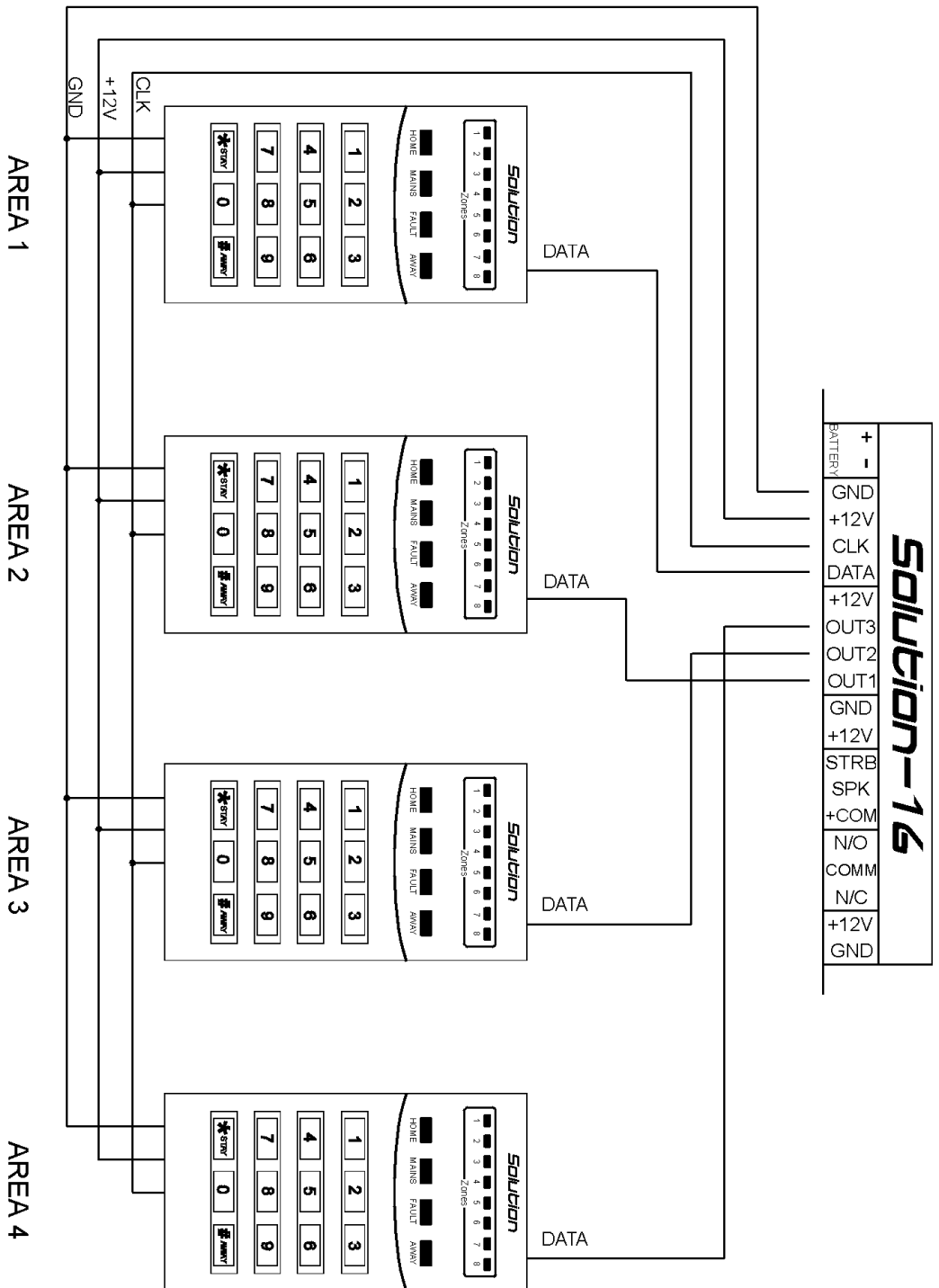

Figure 10: Connections For "CP5 Area Addressable (CP500A)" Codepads



# ***Optional Equipment***

---

## **Optional Equipment**

EDM manufactures numerous accessories that can be used in conjunction with the *Solution-16* control panel. These optional pieces of equipment will enhance certain features thus making the system extremely flexible.

### **EDMSAT - Satellite Siren (SS914)**

The EDMSAT Satellite Siren is a totally self contained unit incorporating a high powered siren and a weatherproof strobe. A 1.2 AH sealed lead acid battery needs to be fitted. The EDMSAT requires only two wires for operation on which the charging of the battery and triggering of the siren and strobe are carried out. This is done by pulse code modulating (PCM) the charging voltage. Any attempt to tamper with the wiring or to substitute an alternative power source across the wiring will disrupt the data transmission and the EDMSAT will activate immediately. When the EDMSAT carries out a battery test, the unit will sound for two seconds if the battery test fails.

### **EDMSTU - Securitel Interface (CS800)**

This EDMSTU (Securitel Interface) has been designed to operate in conjunction with the *Solution-16* control panel using a serial connection. This means that all alarm information can be transmitted from the control panel to the EDMSTU using only 3 wires.

The EDMSTU provides full serial reporting of alarms, opening and closing reports, isolations and user ID information. The monitoring control room also monitors line integrity.

### **Hand Held Programmer (CC814)**

The hand held programmer is used to program the locations in the *Solution-16* control panel. The unit displays the actual location number and the data value currently programmed. It comes complete with a one metre connecting cable and a socket for an external programming key.

### **Programming Key (CC891)**

The programming key is a unique device that will store all programming information programmed in your control panel once copied to the programming key. The programming key can hold all your common configuration data such as monitoring station telephone numbers and zone reporting channels etc.

### **Modem Module (CC811)**

This modem module is required when the control panel is to report to a PET Alpha Pocket Pager Protocol using the CCITT frequency.

#### **Connection**

Ensure that all power is disconnected from the *Solution-16* control panel. Locate the AUXILIARY MODULE socket on the printed circuit board and connect the modem module ensuring that the orientation of the triangular markings on the printed circuit board correspond to those on the modem module.

### **Modem Module (CC811B)**

This modem module is required when the control panel is to report to a PET Alpha Pocket Pager Protocol using the BELL frequency.

#### **Connection**

Ensure that all power is disconnected from the *Solution-16* control panel. Locate the AUXILIARY MODULE socket on the printed circuit board and connect the modem module ensuring that the orientation of the triangular markings on the printed circuit board correspond to those on the modem module.

### **Voice Module (CC888)**

The voice module has been designed so that a clear concise voice message can be transmitted by the control panel to the domestic phone numbers of your choice when an alarm condition occurs. This allows the person receiving the call to easily understand that the control panel at your home or office has been activated and that action is required.

This voice message is pre-recorded by the installer and can be changed as many times as necessary. The message can be any length between 1-16 seconds.

Refer to "Synthesised Voice Reporting" on page 80 for more information



**Telephone Line Fault Module (CC887)**

This module is used to monitor the existence of the telephone line connected to the control panel. There are a number of options for the different type of indications available when a line fault has been detected. Refer to "LOCATION 673" on page 164 for the different options available.

**DTMF Command Module (CC886)**

This module is required to be connected to the control panel if any remote programming or operating commands are required to be carried out from a touch tone telephone. Refer to "LOCATION 671" on page 160 for more information on the available options that may be enabled. Refer to "Operating The Control Panel Using The DTMF Command Module" on page 67 for more information on operational procedures.

**Dialler Amplifier Lead (CC807)**

This lead is required when using a telephone amplifier for listening to the data transmissions between the control panel and the base station receiver. The standard inductive pick-up that is supplied with the amplifier is not compatible with the *Solution* range of control panels. This lead plugs into the amplifier unit and onto the AUXILIARY MODULE socket on the *Solution-16* control panel.

**Alarm Link Software (CC816)**

This software package is designed to be used for programming the *Solution-16* control panel by either the direct link or remote connect methods. All options and features can be accessed via this software as well as maintaining history and service reports. Refer to "LOCATION 663" on page 150 for enabling this feature.

**Direct Link Cable (CC808)**

The *Solution-16* control panel has the ability to be programmed using the Alarm Link software without the need of a remote telephone line connection. Using the direct link method, one end of this cable plugs directly onto the AUXILIARY MODULE socket of the *Solution-16* control panel with the other end going to a serial communications port of an IBM or compatible computer. The control panel can be programmed in the same way as one would if a telephone line was used.

**Eight Channel Output Board (CC884)**

The eight channel output board is used to increase the available programmable outputs that can be operated from the control panel. An additional eight outputs can be monitored using this expansion board. Refer to Option 2 in "LOCATION 672" on page 161 to enable the eight channel output board. Refer to "Figure 17: Eight Channel Open Collector Output Board (CC884)" on page 196 for connection information.

**Eight Zone Expansion Board 3K3 EOL (CC885)**

This eight zone expansion board provides terminations for zones 9-16 when the configuration of split EOL resistors is not suitable. 3K3 EOL resistors must be used with this board. Refer to "LOCATION 672" on page 161 to enable this zone expansion board.

**Eight Zone Expansion Board Variable EOL (CC883)**

This eight zone expansion board provides terminations for zones 9-16 when the configuration of split EOL resistors is not suitable. This board is supplied with different value EOL hybrids for the available resistors that may be used. There is no longer a need to replace the EOL resistor when replacing an existing control panel with a *Solution-16*. Refer to "LOCATION 672" on page 161 to enable this zone expansion board.

**Termination Block For JP5 Pins (CC882)**

This termination block provides two terminals when using the JP5 pins EXP and GND for keyswitch operation for arming and disarming the system. Refer to Options 3-12 in "LOCATION 672" on page 161 for more information.

**CP5 Eight Zone Codepad (CP508)**

This codepad is designed to operate with the *Solution* range of control panels. It provides indications for up to 8 zones. This codepad cannot be used with any system that has been partitioned.

**CP5 Sixteen Zone Codepad (CP516)**

This codepad is designed to operate with the *Solution* range of control panels. It provides indications for up to 16 zones. This codepad cannot be used with any system that has been partitioned.

**CP5 Area Addressable Codepad (CP500A)**

This codepad is designed to operate with the *Solution* range of control panels. It provides indications for up to 8 zones. This codepad is designed to be used in any system that has been partitioned. These codepads have dip switches on the printed circuit board to indicate which area in partitioning that the codepad belongs to. Refer to "Codepad Connections For Partitioning" on page 180 for further information on how to connect these codepads.

**CP5 Master Partitioned Codepad (CP500P)**

This codepad is designed to operate with the *Solution* range of control panels. It provides indications for up to 8 zones. This codepad is designed to be used in any system when the system has been partitioned. These codepads allow the user to toggle from one area to another without the need to go to each area codepad. Refer to "Codepad Connections For Partitioning" on page 180 for further information on how to connect these codepads.

**Night Arm Station (CP105)**

The night arm station incorporates a panic button and is designed to allow system operation from a bedroom or sitting room to arm and disarm the system in STAY Mode 1.

**Phone Controller (CC911)**

The phone controller operates at a frequency of 1400 Hz and allows the user to remotely arm the system in AWAY Mode via the telephone. This phone controller can also be used to acknowledge a phone call from the control panel when the system is set up for domestic dialling.

**Hand Held Dialler Tester (DD901)**

The hand held dialler tester simulates a base station for testing of the control panel's dialling functions. It communicates in most formats.

**Cellular Dialler**

The cellular dialler when connected to the control panel will transmit alarm information via the cellular phone network to the base station receiver when a land telephone line is not present or has been tampered with.

**PS100 Power Supply Module (PS100)**

The PS100 Power Supply Module has been designed for applications requiring 13.8 volts DC at currents of up to 1 Amp and must be used in conjunction with the TF008 - 18 volt AC plug pack.

The unit comes complete with our standard, fully short circuit proof, power out and battery charging terminals as well as a DC LED indicator and AC mains fail output. For situations requiring an uninterrupted power source, a rechargeable sealed lead-acid battery can be fitted. In the event of a mains failure, the power supply will switch to battery power without interrupting the load being supplied.

**TF008 Plug Pack (TF008)**

The TF008 plug packs have been designed to be used with the EDM control panels and the PS100 Power Supply Module. The plug pack includes built in thermal fuses which under overload or fault conditions will blow and eliminate any possible fire threat due to excessive heat build up inside the casing.

The TF008 plug pack incorporates a three wire flying lead that enables a mains earth connection to be made between the equipment and the plug pack. This connection may be required for lightning protection on equipment that is connected to phone lines or for safety reasons such as earthing of metal enclosures.

### **Solution Codepad Mimic Board (CC820)**

The Solution Codepad Mimic Board (CC820) has been designed to allow you to have a separate output indicator for each indicator found on the remote codepad. This will be useful to remotely display system status information.

### **Solution Relay Output Interface (CC892)**

The Solution Relay Output Interface (CC892) has been designed to allow up to an additional 8 relay outputs to be connected to a Solution control panel. This will be useful to remotely display system status information.

The 3 way DIP switch on the board is used to select the data that is to be displayed on the relays. Multiple interfaces may be connected in parallel for different data displays.

### **2 Wire Smoke Detector Interface (FA101)**

The 2 Wire Smoke Detector Interface (FA101) has been designed to allow high quality 2 wire, 24 volt DC smoke detectors to be easily connected to the Solution range of control panels. The interface provides the 24 volts required to power the smoke detector and also provides a relay output that is used to trigger the control panel. Multiple detectors may be connected to the same interface.

### **Radio Key/Keyswitch Interface (CC813)**

This interface was designed to allow simple interfacing of a momentary keyswitch or radio equipment for remote control operations to operate the control panel.

If the R/K terminal is used, a number of momentary keyswitches may be connected in parallel for multiple arm/disarm locations. The ON and OFF terminals can be used to directly interface to any access control system.

For non partitioned control panels, the HOME Mode terminal will force the system to arm and disarm in STAY Mode 1.

There is also a PANIC terminal that allows the customer to issue a panic alarm from a remote keyswitch or hand held radio transmitter.

This is handy if you require your system to be radio controlled and you would like to give your customer total control via a hand held radio remote.

Indication beeps can be provided via the horn speakers when arming and disarming using this interface board. Refer to Option 8 in "LOCATION 665" on page 152 for more information. As you can see the radio key/keyswitch interface allows you the flexibility to perform quite a number of functions cheaply and easily.

<b>No Of Beeps</b>	<b>System Status</b>
<b>1</b>	System Disarmed
<b>2</b>	System Armed In AWAY Mode
<b>3</b>	System Armed In STAY Mode 1

*Table 131: Horn Speaker Beeps*

### **2 Channel Radio Interface (RE005)**

The EDM 2 channel radio interface has been designed to allow customers to remotely operate Solution control panels and control two on-board relays. The interface may also be used as a stand alone receiver, independent of a Solution control panel and used solely for remote control of external devices connected to the two on-board relays.

The interface's operating frequency is 304 Mhz with the ability to store up to 120 radio remote codes. When connecting the interface to a Solution control panel, there is only a three wire connection in parallel to the codepad and Option 1 In LOCATION 666 on page 153.

# Radio: On - Off - Home - Panic

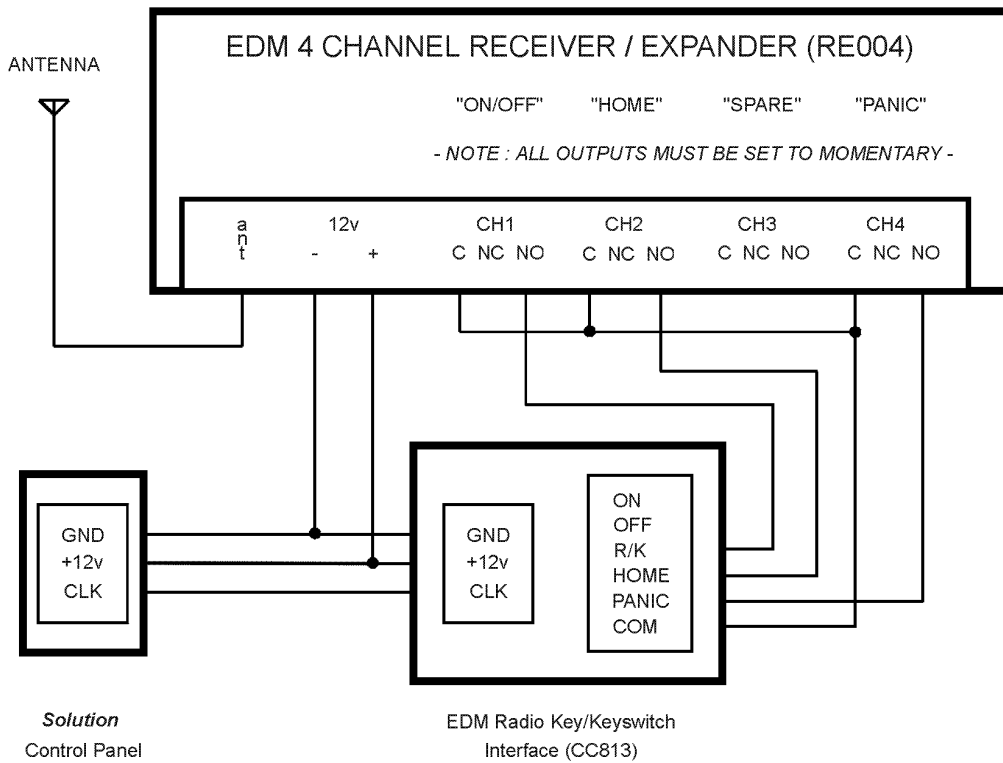

**NOTE:**  
R/K BEEPS MUST BE ENABLED (IF REQUIRED)  
LOCATION 665 MUST CONTAIN = 8

# Keyswitch: On / Off

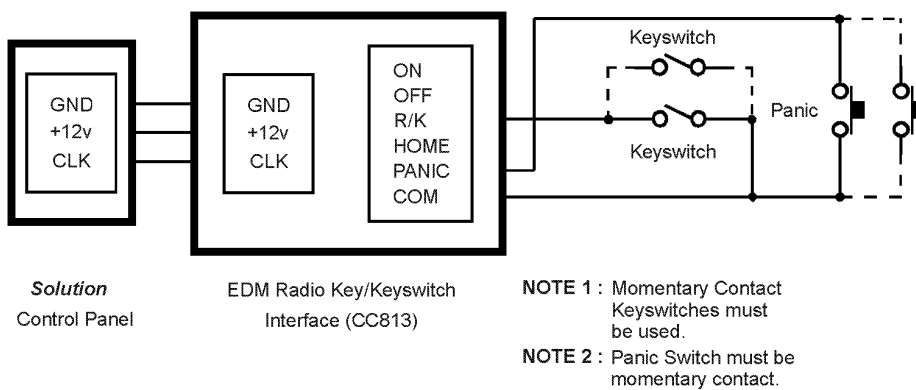

**NOTE 1 :** Momentary Contact  
Keyswitches must  
be used.  
**NOTE 2 :** Panic Switch must be  
momentary contact.

**NOTE:**  
ENABLE KEYSWITCH INTERFACE MODULE  
LOCATION 666 MUST CONTAIN = 1

Figure 11: Radio Key/Keyswitch Interface (CC813) Connection Diagram

## Keyswitch: On / Off - Panic

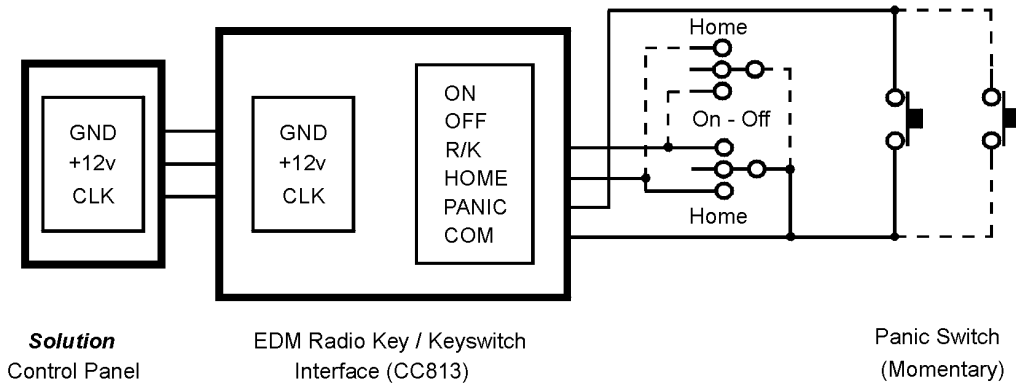

**NOTE:**  
ON / OFF - HOME SWITCHES  
MUST BE MOMENTARY

## Access Control: On / Off

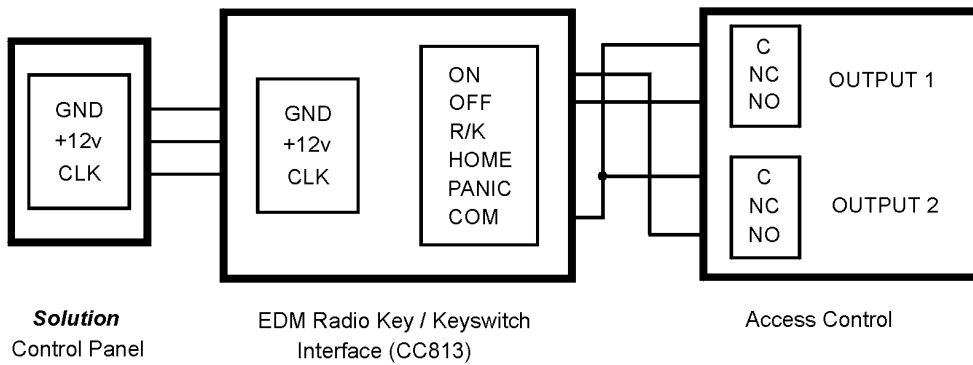

## Radio Key: On / Off

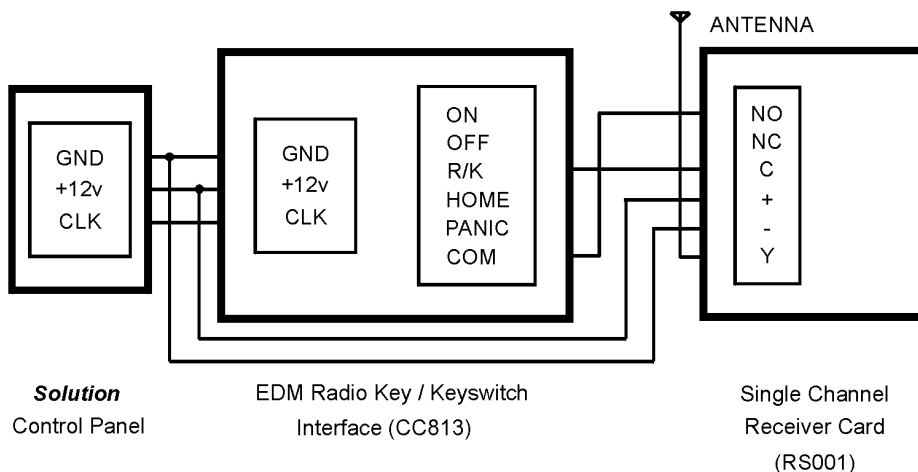

Figure 12: Radio Key/Keyswitch Interface (CC813) Connection Diagram



# ***Terminal Definitions and Descriptions***

---

## **This Section Includes The Following:**

- *Terminal Definitions and Descriptions*
- *Solution-16 Wiring Diagram*
- *Eight Zone Expansion Board (CC885)*
- *Eight Zone Expansion Board (CC883)*
- *Connections Of Split EOL Resistors For 16 Zone Operation*
- *Eight Channel Open Collector Output Board (CC884)*
- *Connection For Momentary Or Latching Keyswitch*
- *Connections For 25 Pin Logging Printer*
- *Connections For 9 Pin Logging Printer*
- *Solution-16 Component Overlay*
- *How to Install the BNC Fitting*
- *How to Mount the Radio*
- *Telecom Connection Diagrams*

## Terminal Definitions and Descriptions

Terminal	Definition
<b>EARTH</b>	This terminal should be connected to the green wire on the TF008 Plug Pack that is internally connected to the mains earth. Extensive lightning protection has been built into the control panel and this terminal will have to be connected correctly if you are to take the best advantage of the protection provided.
<b>18V AC</b>	These two terminals are plug on type, and are the termination point for the TF008 Plug Pack. The voltage of the plug pack being used must be 18 - 22 volts AC and rated at 1.3 Amps minimum for correct operation.
<b>+BATTERY</b> <b>-BATTERY</b>	<p>The + BATTERY connects to the red positive terminal of the battery and the - BATTERY connects to the black negative terminal of the battery. The battery should be a 12 volt sealed lead acid rechargeable type with a capacity of between 1.2 AH - 6.5 AH. The battery is protected by a 3 Amp fuse.</p> <p>The charging globe which is situated above the 3 Amp fuse will always be illuminated until the battery is 100% charged. Because the battery is pulse charged it is not possible to read 13.8 volts from the battery leads. A nominal measurement of 5.6 volts will be evident on a digital meter when the battery has been disconnected.</p>
<b>GND</b> <b>+12V</b> <b>CLK</b> <b>DATA</b>	<p>This group of terminals are the connection points for your system codepads. All system codepads should connect in a parallel configuration back to these terminals. The only factor restricting the number of codepads that can be connected is the available power and its distribution. Each codepad has a maximum power requirement of 60 ma with all indicators illuminated, therefore this should be taken into consideration when calculating your available continuous power. The total continuous external load on the system should not exceed 1 Amp maximum.</p> <p><b>Note: If the system has been partitioned, the connection of codepads will be different. Refer to "Codepad Connections For Partitioning" on page 180 or "Setting Up and Programming Codepads For Partitioning" on page 179 for more information.</b></p>
<b>+12V</b> <b>OUT3</b> <b>OUT2</b> <b>OUT1</b>	<p>This group of terminals are the output interface terminals. They can be configured to any combination of the functions available via the system programming options. They can be used for a variety of functions with incredible flexibility. All outputs have a common terminal that is positive 12 volts and each output is capable of sinking a maximum of 1 Amp.</p> <p>The outputs are protected by EDM's unique Integrated Protection System, [IPS]. This makes them extremely tolerant to abuse or incorrect wiring. It should be noted that each output is open collector and will not source any current but can sink a maximum of 400 ma per output.</p>
<b>GND</b> <b>+12V</b>	These two terminals are provided to power detectors and other equipment. They are fuse protected by the 1 amp fuse.
<b>STRB</b> <b>SPK</b> <b>+COM</b>	<p>This group of terminals is protected by EDM's solid state IPS system, giving them incredible tolerance against short circuits.</p> <p>The STRB terminal (Output 4) is fully programmable as with outputs 1,2 and 3. This output is factory set as the strobe output and is the connection point for the negative side of a strobe light. The positive side of the strobe is connected to the +COM terminal. This output is normally open circuit going low and is capable of sinking 400 ma.</p> <p>The SPK terminal is the reflex horn speaker output with the common terminal being +COM. There are fifteen different sounds available for the horn speaker. Refer to "Siren Sound Rate" on page 145 for more information. A maximum of two 8 ohm horn speakers may be connected in parallel.</p>



<b>Terminal</b>	<b>Definition</b>
<b>N/O</b> <b>COMM</b> <b>N/C</b>	<p>These relay contacts are fully programmable as with Outputs 1, 2 and 3. They are factory defaulted as an alarm output (Sirens Running - Event Type 1,15).</p> <p>The N/O contact is the connection point for the positive side of a DC siren such as a piezo screamer. The negative side of the DC siren needs to be connected to the GND terminal. A link (JP7) is provided on the PCB for connecting the COM terminal to either GND or 12V. This link should be connected to +12V as shown in "Figure 13: Solution-16 Wiring Diagram" on page 194. The relay is rated at 1 Amp/30 VDC.</p>
<b>+12V</b> <b>GND</b>	<p>These two terminals are provided to power detectors and other equipment. They are fuse protected by the 1 amp fuse.</p>
<b>+12V</b> <b>Z1</b> <b>Z2</b> <b>Z3</b> <b>Z4</b>	<p>These terminals are zones one to four and their common terminal is +12V. All normally closed contacts are to be connected in series with the EOL resistor, where all normally open contacts are to be connected in parallel with the EOL resistor. The function of the zones and their response times are programmable via the system programming options.</p>
<b>+12V</b> <b>GND</b>	<p>These two terminals are provided to power detectors and other equipment. They are fuse protected by the 1 amp fuse.</p>
<b>Z5</b> <b>Z6</b> <b>Z7</b> <b>Z8</b> <b>+12V</b>	<p>These terminals are zones five to eight and their common terminal is +12V. All normally closed contacts are to be connected in series with the EOL resistor, where all normally open contacts are to be connected in parallel with the EOL resistor. The function of the zones and their response times are programmable via the system programming options.</p>
<b>+12V</b> <b>GND</b>	<p>These two terminals are provided to power detectors and other equipment. They are fuse protected by the 1 amp fuse.</p>

# Solution-16 Wiring Diagram

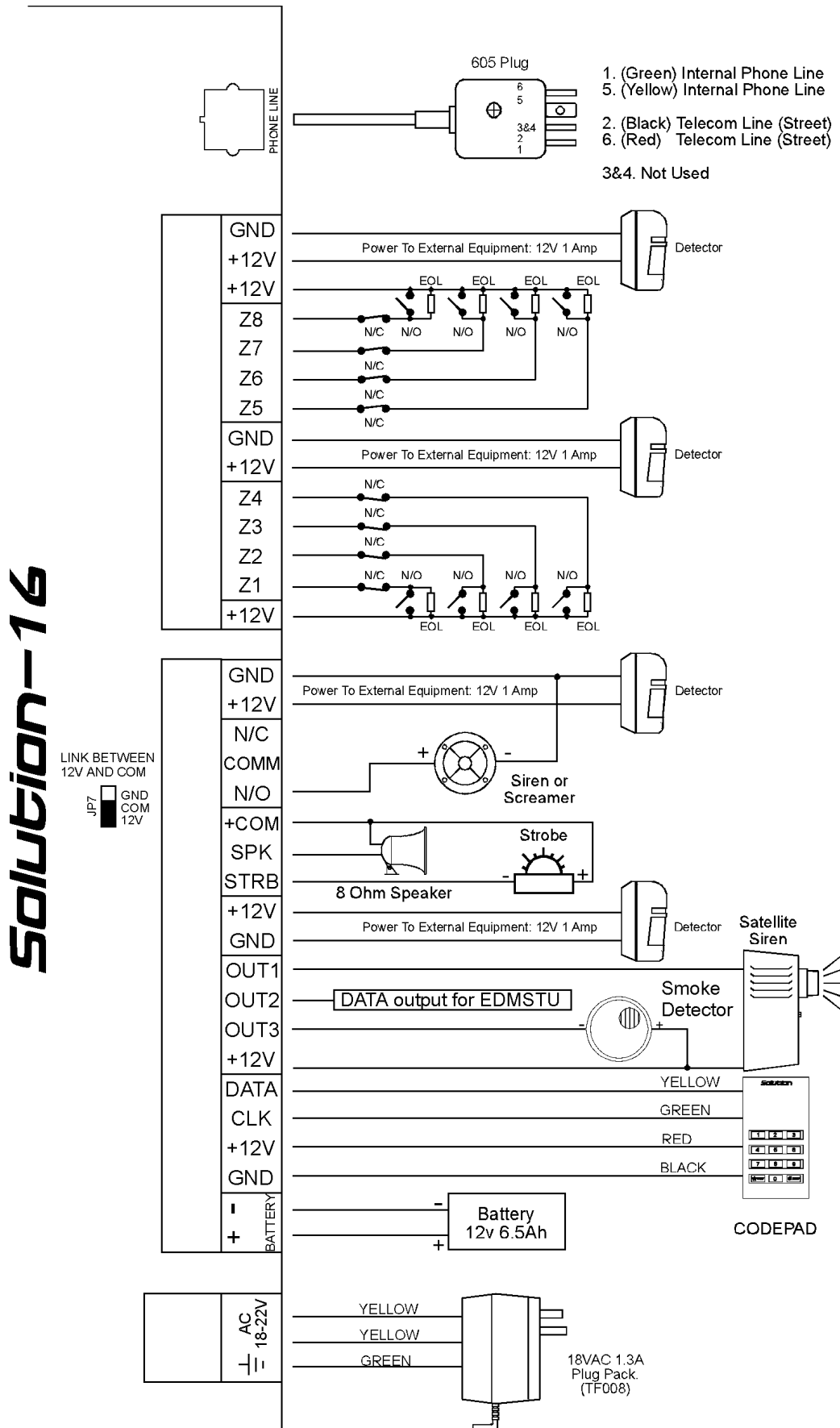

Figure 13: Solution-16 Wiring Diagram

### Eight Zone Expansion Board (CC885) - Fixed 3K3 EOL Resistors

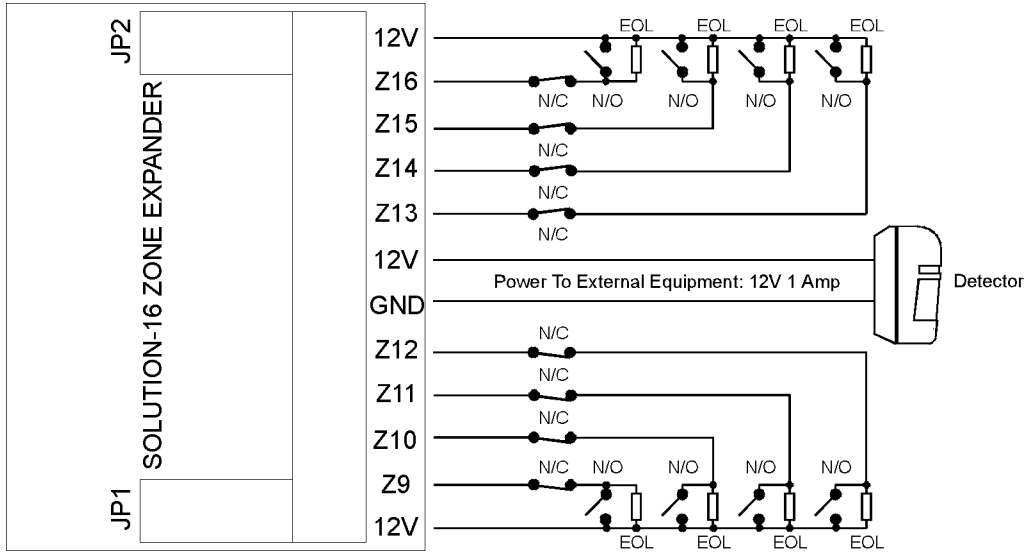

Figure 14: Eight Zone Expansion Board (CC885) - Fixed 3K3 Ohm EOL Resistor

### Eight Zone Expansion Board (CC883) - Variable EOL Resistors

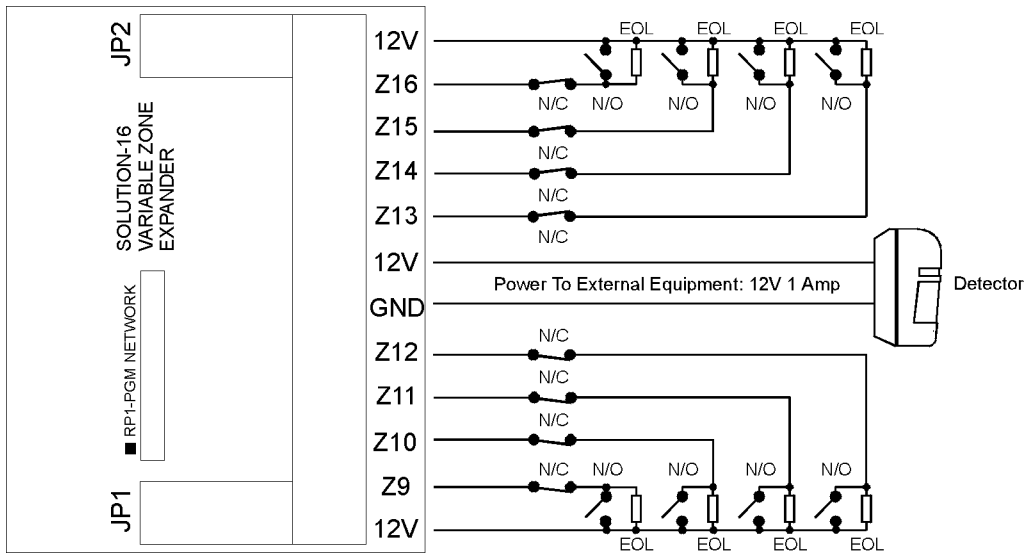

Figure 15: Eight Zone Expansion Board (CC883) - Variable EOL Resistor

### Connections Of Split EOL Resistors For 16 Zone Operation

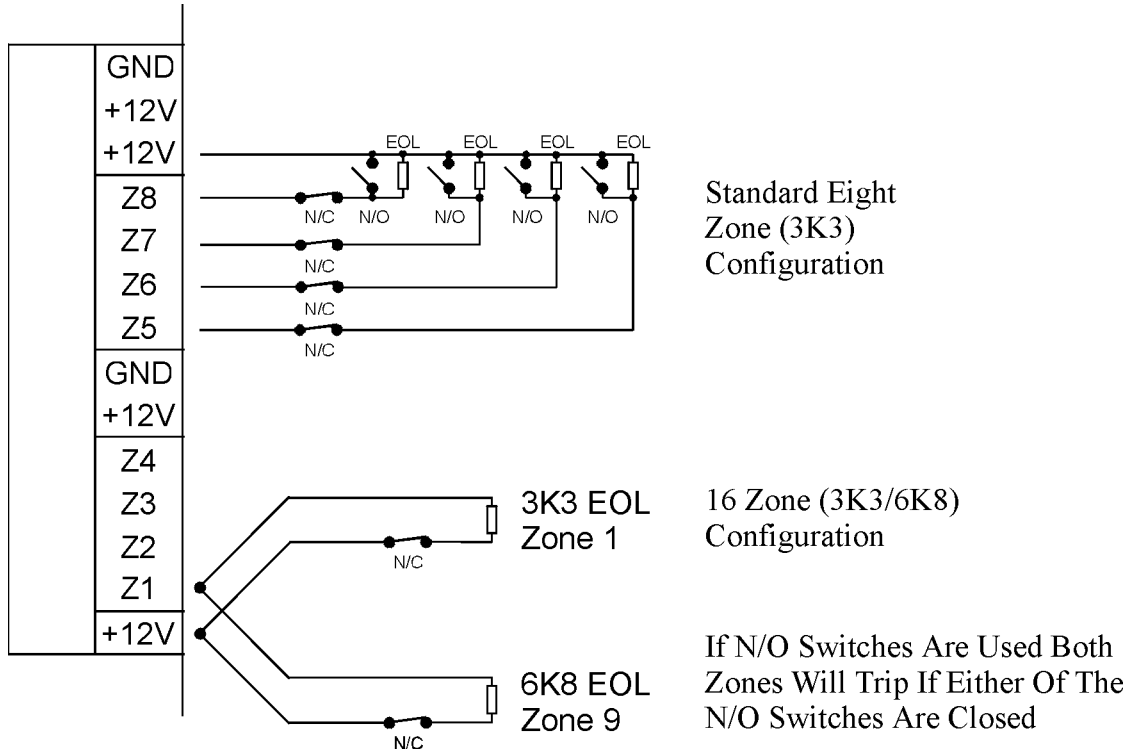

Figure 16: Connections Of Split EOL Resistors For 16 Zone Operation

### Eight Channel Open Collector Output Board (CC884)

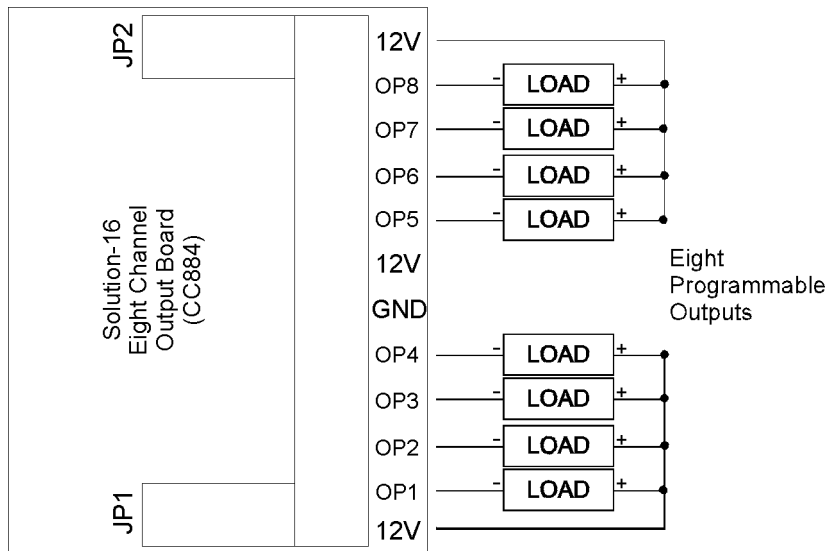

Figure 17: Eight Channel Open Collector Output Board (CC884)

Maximum current is 400 ma per Output

### Connection For Momentary Or Latching Keyswitch

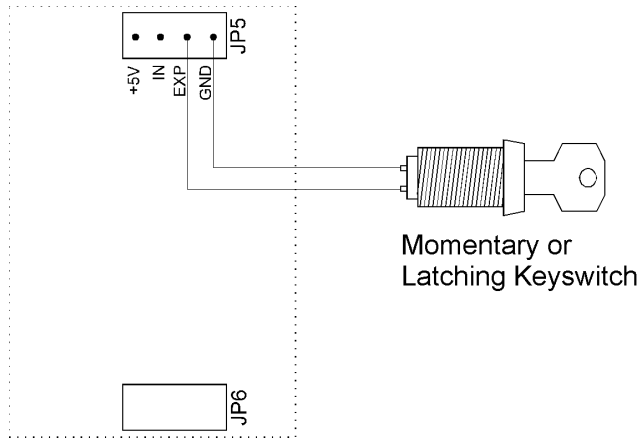

Figure 18: Connection For Momentary Or Latching Keyswitch

### Connections For 25 Pin Logging Printer

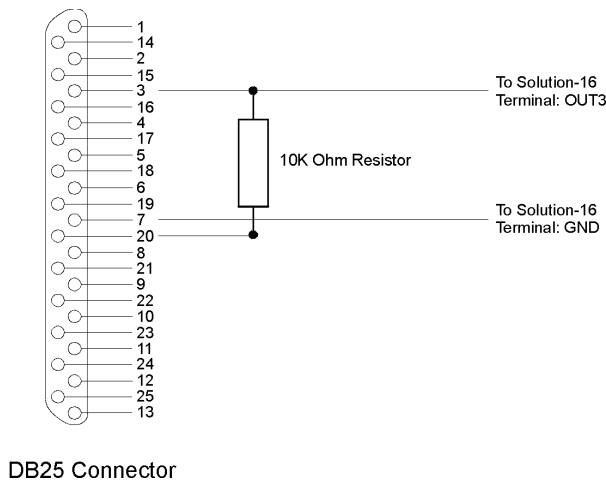

Figure 19: Connections For 25 Pin Serial Logging Printer

### Connections For 9 Pin Logging Printer

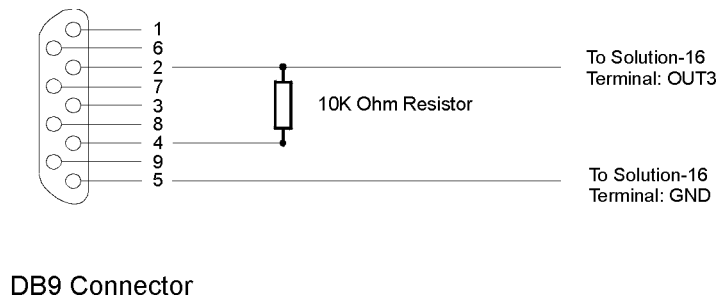

Figure 20: Connections For 9 Pin Serial Logging Printer

### Solution-16 Component Overlay

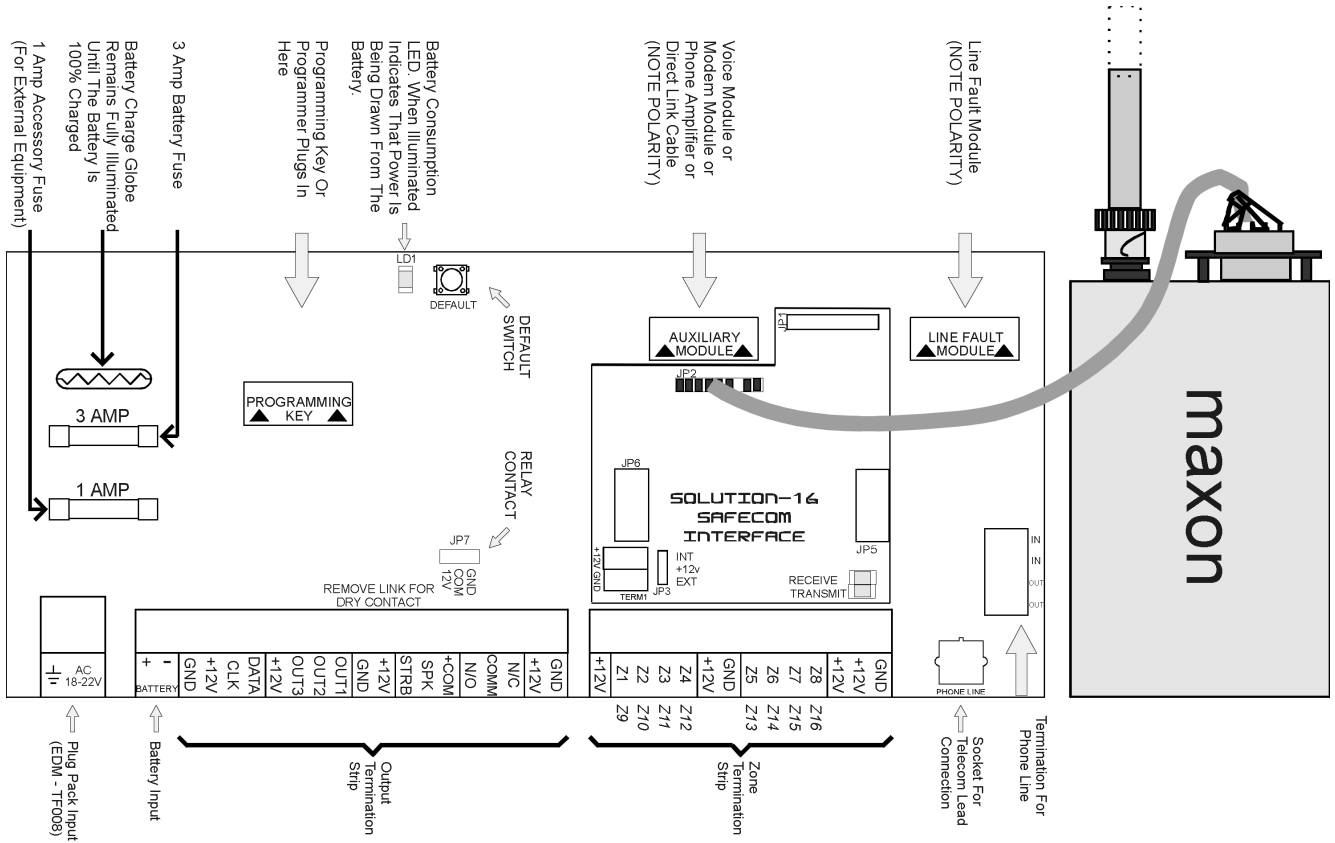

Figure 21 Solution-16 Component Layout With Safecom Interface

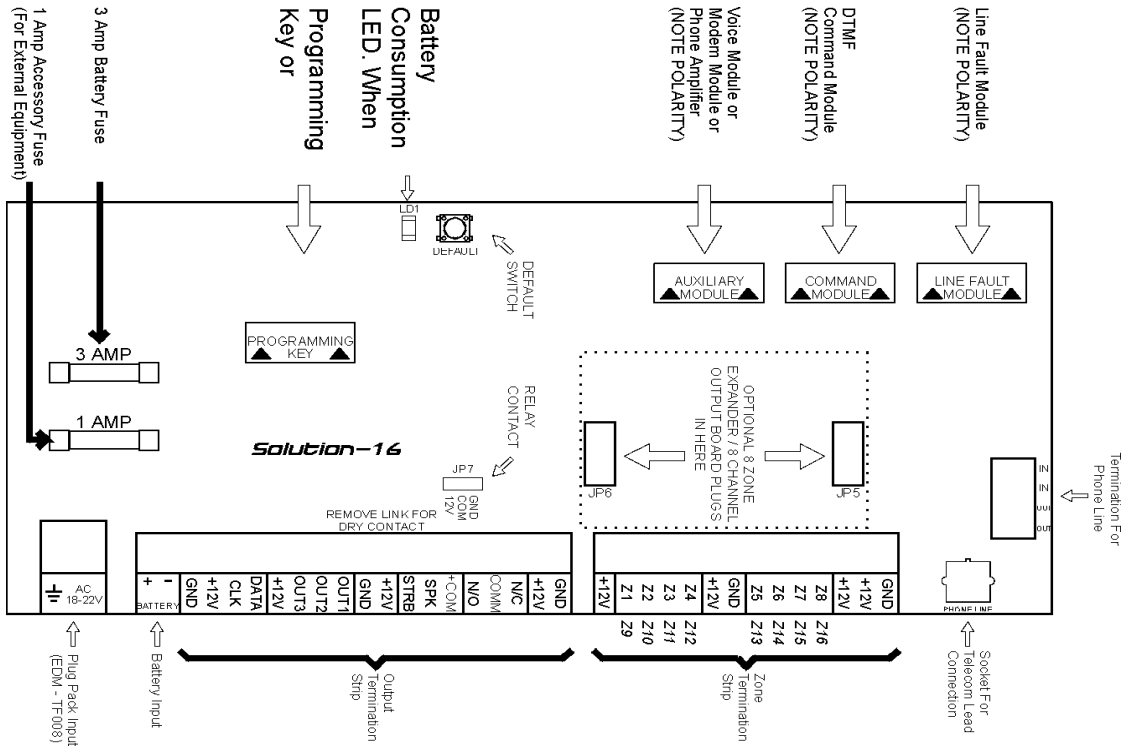

Figure 22: Solution-16 Component Layout

### Solution-16 Safecom Interface

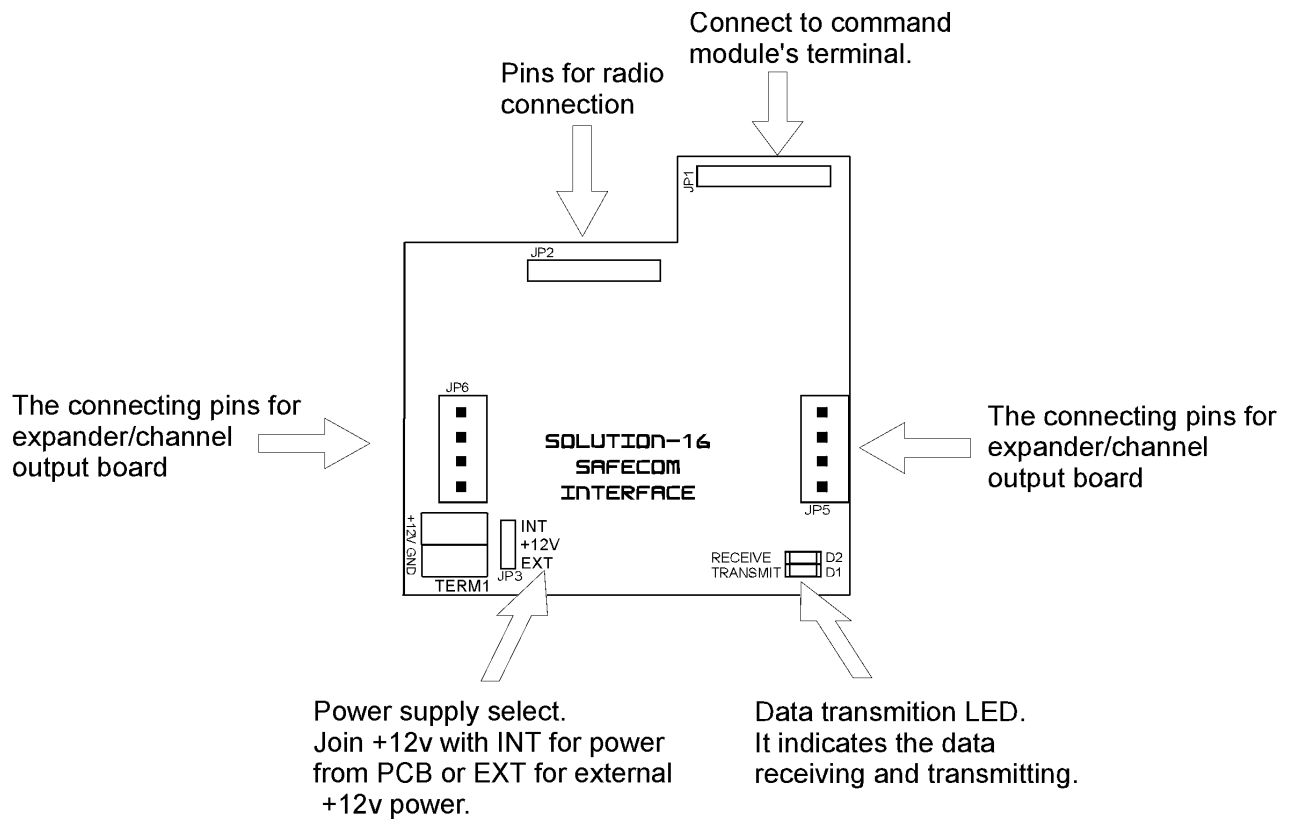

Figure 23: Solution-16 Safecom Interface

### How to Install the BNC Fitting

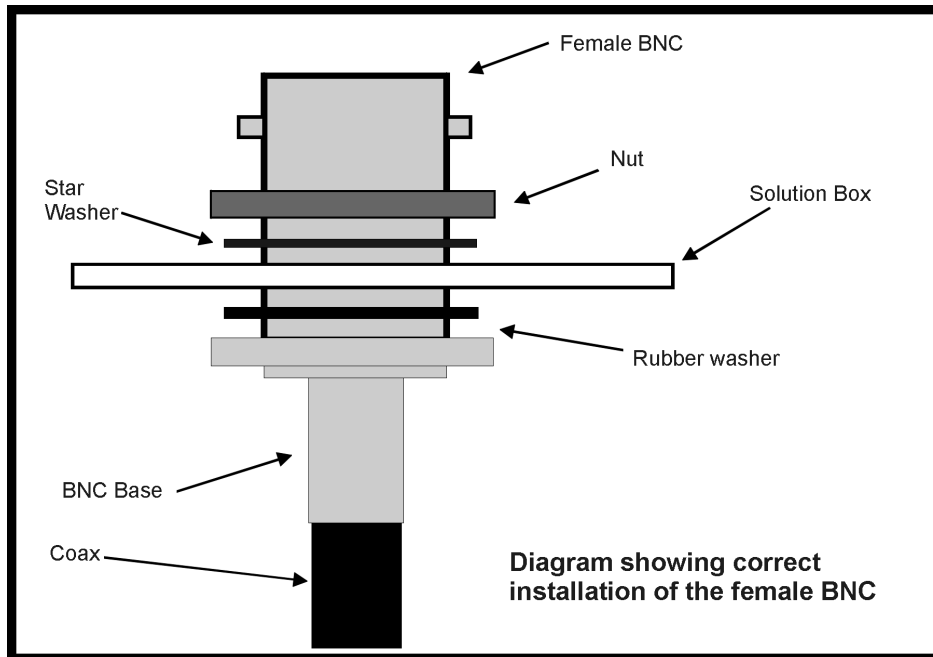

Figure 24: BNC Installation Diagram

### How to Mount the Radio

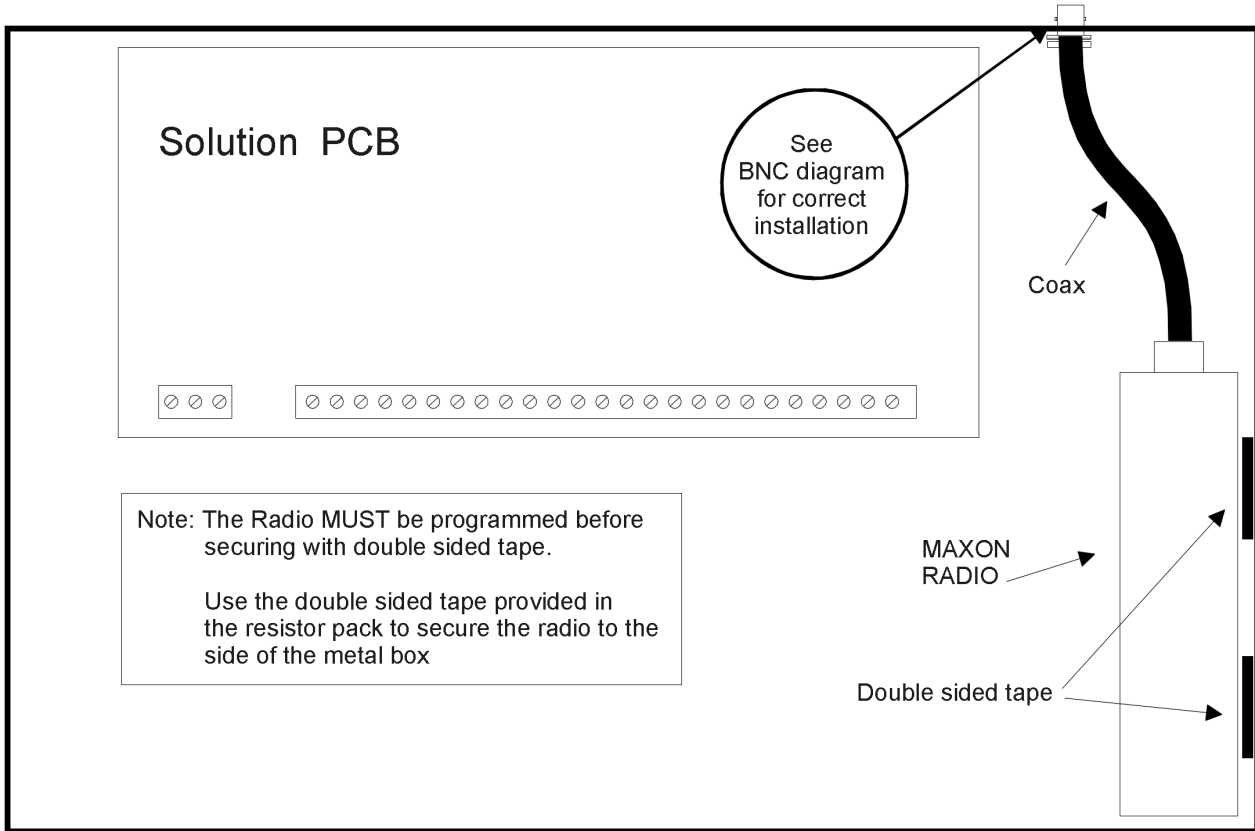

Figure 25: Radio Mounting For SC8016

### Mounting the Radio

Before attempting to mount the radio in the metal cabinet the Radio must be programmed with the correct information such as transmit and receive frequencies, transmit power and bandwidth. If you are unable to program this information then please contact your nearest Detection Systems office for assistance.

Once programmed, proceed with mounting the Radio in the metal cabinet by placing the double sided tape on the base of the Maxon Radio as in Figure 25. Then connect the coax cable to the metal cabinet as in figure 24 then attach the male BNC to the Maxon Radio. Finally connect the wiring harness to the Radio and the SAFECOM *Solution-16* interface.



# Telecom Connection Diagrams

## TELECOM CONNECTION DIAGRAM FOR AUSTRALIA

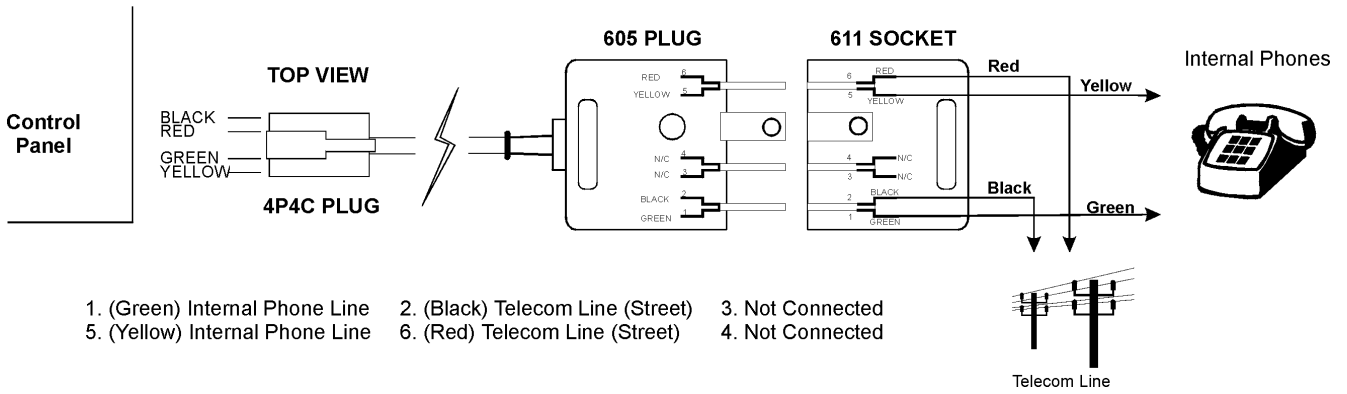

## TELECOM CONNECTION DIAGRAM FOR AUSTRALIA

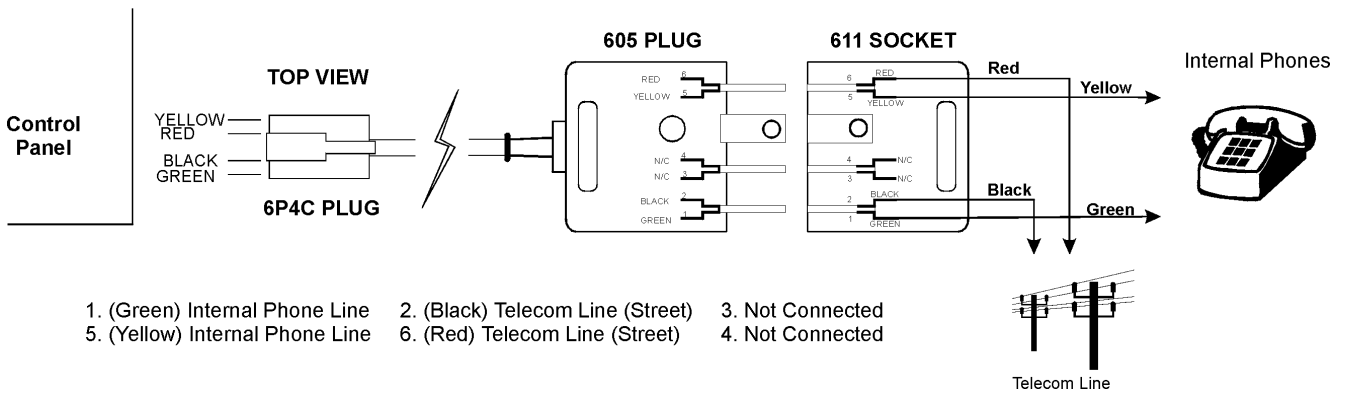

## TELECOM CONNECTION DIAGRAM FOR NEW ZEALAND

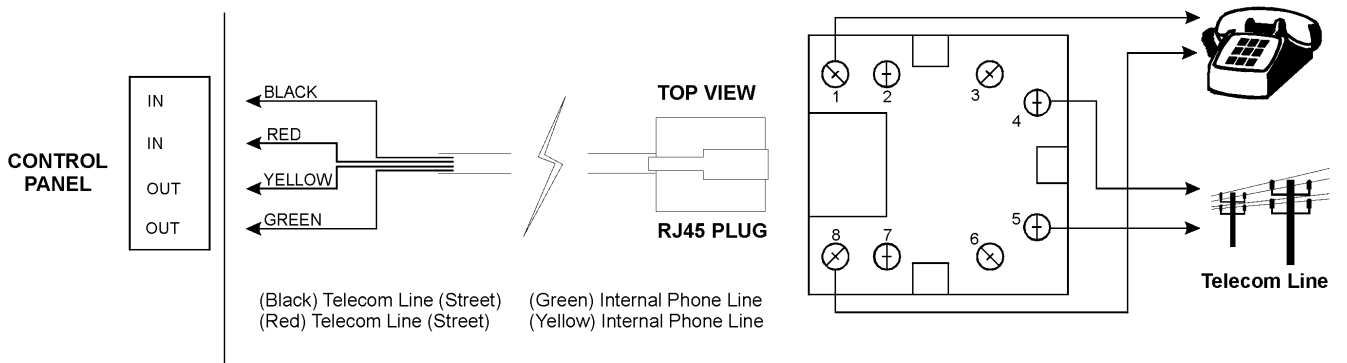

## TELECOM CONNECTION DIAGRAM FOR CHINA

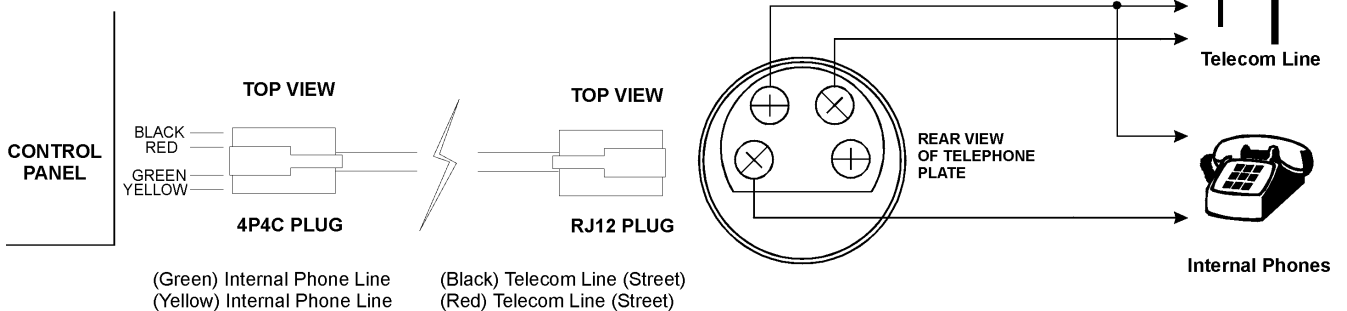

Figure 26: Telecom Connection Diagrams For Solution-16



# Appendices

---

**This Section Includes The Following:**

- *Telephone Anti-Jamming*
- *Test Reports Only When Armed*

## Appendix A

### Telephone Anti-Jamming

There are many companies today importing American designed products that claim to have Anti-Jamming and believe it or not, they push this feature as if it were a major break through in control panel technology. Well this in fact is not the case at all as most control panels have some sort of Anti-Jamming feature. We can go as far back as the early 1980's where even the 678 diallers incorporated a form of Anti-Jamming as a standard programmable option.

The important thing to note is that as most American designed products are primarily aimed at their local market and telephone networks, when they are imported to Australia their anti-jamming function does not perform as it should.

To clear up just what anti-jamming is and how it works needs some understanding of Telephone Networks. In America either of the two parties (ie. the one who initiated the call or the one receiving the call) can clear the line by placing the hand piece back on the hook. If you pick up the hand piece again, dial tone will be received and you will be able to make a new call immediately. This is not so here in Australia.

In Australia, only the calling party can immediately terminate the call. If you receive a call from someone and hang up on them, picking the hand piece back up again to make a new call only reconnects you to the original caller. It will not be possible to make another call until the original caller hangs up or you hang up phone for ninety seconds or longer. So you see Australia is very different and needs a special form of anti-jamming to suit our telephone network.

There are control panels on the market that after making a few call attempts which fail simply hang up and wait for ninety seconds or so, in an attempt to clear the jamming incoming call. This may work in some instances where the caller is not a genuine burglar and is not deliberately trying to jam the control panel. With this simple method of hanging up for ninety seconds we have not only delayed the alarm signal for this time but also the time taken for the original failed call attempts which could easily total 4 minutes. This is bad enough in its own right but even more disturbing is the fact that the initial failed call attempts allow for the establishment of an audio connection between the would be burglar and the control panel. Anyone with a little knowledge of alarm systems will be able to actually trick the dialler into thinking it is talking to a base station thus actually clearing the alarm signal. Pretty frightening when you thought the control panel you were using and recommending to your customers is supposed to have anti-jamming.

At Electronics Design and Manufacturing Pty Limited we take anti-jamming very seriously and have in fact devoted a great deal of time and money researching this problem. Our engineers have come up with the best possible anti-jamming procedure known and patented accordingly {Patent Number 571994}.

Our procedure is very simple and effective because we never answer the burglars phone call and the Telecom Network will automatically clear an unanswered call in approximately ninety seconds. This time will be even shorter if the call is originated through the Mobile-Net Network where it will most likely be in the case of a true burglary.

Once the control panel detects that the phone line has stopped ringing it immediately loops the line and makes its call therefore transmitting its alarm message successfully. The line is also automatically disconnected from the telephones within the protected premises immediately on an alarm condition by the control panel to further confuse the burglar and eliminate the possibility of the burglar answering the call. As you can see, our method of anti-jamming will in the worst possible case delay the alarm signal by ninety seconds but even more importantly will never allow for an audio connection between the burglar and the control panel.

All dialling products produced by Electronics Design and Manufacturing Pty Limited have incorporated this true anti-jamming feature as standard since 1985 and we do not consider it as an option but a must in any professional security system.

True anti-jamming can only be found in products produced by Electronics Design and Manufacturing Pty Limited and any other manufacturer can only offer second best due to our patent on this very unique and effective procedure.

## Appendix B

### Test Reports Only When Armed

The *Solution-16* control panel allows for test reports to be transmitted to the base station receiver to verify that the dialler functional. So what you might say, as most alarm diallers allow you to do this.

The one problem with this is that installations that report opening and closing reports will generally also transmit a test report each day. This call is unnecessary, as a successful opening and closing report means that the dialler is functioning correctly.

The *Solution-16* control panel allows you to save time and money by providing test reports only while the system is in the armed state.

Program "LOCATION 506 - 513" on page 122 with Option 1 (Send test reports only if the system is armed), and then set the test report time to be in the middle of the day. During Monday to Friday when the premises are generally open and the system disarmed a test report will not be transmitted. However, on the weekend, the premises will be closed and the system armed, so a test report will be transmitted at the programmed time thus verifying the operation of the dialler.

At first glance this may not seem to be a big deal but lets do a few sums and you will see just where savings can be made.

Let us assume that the customer wants, needs or has test reports programmed for once a day as well as opening and closing reports. This means that at least three phone calls will be made each week day and one call on Saturday and one call on Sunday.

By using the *Solution-16* control panel you will be able to eliminate five calls per week. This means that over one week you will save your customer \$1.20 and over one year you will save them \$62.40.

Not a bad saving, and remember these figures are for local calls only.

Turning the table slightly, a control room with lets say 1000 customers sending the above mentioned reports, can expect to receive some 884,000 phone calls (\$212,160 assuming local calls) just for reporting opening, closing and test reports over a 12 month period.

If you use the *Solution-16* control panel, you can effectively cut the calls to 624,000 per year (at a value of \$149,760 assuming local calls), a saving of \$62,400. If we now assume that for each call one line is printed on the logging printer, and that one page is filled per 60 calls. You will be able to save 4333 sheets of paper per year and at approximately \$45 per box this becomes a considerable saving.

As you can see using the *Solution-16* control panel will save you money, your customer money and will help conserve our natural resources, in fact, the only people who don't like this feature is Telecom.



# Specifications

---

## **This Section Includes The Following:**

- *Warranty Statement*
- *Specifications*
- *Software Version Number*

## Warranty Statement

Electronics Design and Manufacturing Pty Limited warrants this product to be free from defects in material and workmanship for a period of three years from the date of manufacture as indicated by the date stamp and /or the serial number on the product.

Defective units returned by the purchaser at their own expense during this period will be repaired or replaced at the option of the manufacturer. The repair or replacement will be free of charge provided that the defects were not incurred during shipping or handling, or the damage was not due to causes beyond the control of Electronics Design and Manufacturing Pty Limited, such as lightning, excessive voltage, mechanical shock or damage arising out of abuse, alteration or improper application of the equipment.

## Specifications

<b>Temperature Range:</b>	0 - 45 Degrees Celsius
<b>Humidity:</b>	10% - 95%
<b>Power Source:</b>	TF008 Plug Pack - 240 Volt/18 Volt AC @ 1.3 Amp
<b>Stand-By Current:</b>	65 ma
<b>Current Draw In Alarm Condition:</b>	115 ma
<b>Current Draw With No Alarm and Codepad Fitted:</b>	105 ma
<b>Back-Up Battery:</b>	6.5 Ah / 12 Volt DC Rechargeable Sealed Lead Acid Battery
<b>Dimensions:</b>	306 mm x 262 mm x 84 mm (Packed In Carton)
<b>Weight:</b>	2.5 Kg
<b>Austel Approval Number:</b>	A94/02B/0476 (Only With TF008 Plug Pack)
<b>New Zealand Telepermit:</b>	PTC 211/95/246

### Software Version Number

#### LOCATION 999



When using the Hand Held Programmer (CC814), you have the ability to display the software version number of the control panel. Refer to “Command 999 - Display Software Version Number” on page 28 for more information.



# ***Programming Sheets***

---

Location 000 - 015

Page 92

**Primary Telephone Number**

0	0	0	0	0	0	0	0	0	0	0	0	0	0	0	0	0
---	---	---	---	---	---	---	---	---	---	---	---	---	---	---	---	---

Location 016 - 031

Page 93

**Secondary Telephone Number**

0	0	0	0	0	0	0	0	0	0	0	0	0	0	0	0	0
---	---	---	---	---	---	---	---	---	---	---	---	---	---	---	---	---

Location 032 - 047

Page 93

**Callback Telephone Number**

0	0	0	0	0	0	0	0	0	0	0	0	0	0	0	0	0
---	---	---	---	---	---	---	---	---	---	---	---	---	---	---	---	---

Location 048

Page 93

**Dialling Format**

- |                                     |                                       |
|-------------------------------------|---------------------------------------|
| 1 = Australian DTMF                 | 4 = International DTMF                |
| 2 = Australian Decadic              | 5 = Reversed Decadic                  |
| 3 = Alternate DTMF & Decadic (AUST) | 6 = Alternate DTMF & Reversed Decadic |

1
---

Location 049

Page 94

**Handshake Tone**

- |                                   |                           |
|-----------------------------------|---------------------------|
| 1 = HI-LO Handshake (Contact ID)  | 4 = No Handshake Required |
| 2 = 1400 Hz (Ademco TX @ 1900 Hz) | 5 = Pager                 |
| 3 = 2300 Hz (Sescoa TX @ 1800 Hz) |                           |

1
---

Location 050

Page 94

**Transmission Format**

- |                              |                            |                        |
|------------------------------|----------------------------|------------------------|
| 1 = Contact ID               | 6 = 4 + 1 Pulsed Expanded  | 11 = Domestic          |
| 2 = 4 + 2 Expressed          | 7 = 3 + 1 Pulsed Universal | 12 = Basic Pager       |
| 3 = 4 + 2 Pulsed             | 8 = 3 + 1 Pulsed Expanded  | 13 = Reserved          |
| 4 = 4 + 2 Pulsed + Checksum  | 9 = Reserved               | 14 = PET Alpha Pager   |
| 5 = 4 + 1 Pulsed + Universal | 10 = Reserved              | 15 = Synthesised Voice |

1
---

Location 051

Page 95

**Transmission Speed**

- |                        |                            |
|------------------------|----------------------------|
| 1 = 1 Pulse / Second   | 4 = 20 Pulses / Second     |
| 2 = 10 Pulses / Second | 5 = 20 Pulses / Second FDL |
| 3 = 15 Pulses / Second | 6 = 40 Pulses / Second     |

1
---

Location 052 - 055

Page 96

**Subscriber ID Number**

0	0	0	0
---	---	---	---

Location 056 - 062

Page 98

**Installer Code**

1	2	3	4	15	15	15
---	---	---	---	----	----	----

Location 063

Page 96

**Ring Count**

- |   |
|---|
| 15 = Answering Machine Bypass 1                                       |
| 14 = Answering Machine Bypass 2 (New - Software Version 1.37 Onwards) |

8
---

Location 064 - 319

Page 98

**User Codes**

<p><b>User Code 3</b> Location 080 - 087</p> <table border="1"> <tr> <td>15</td><td>15</td><td>15</td><td>15</td><td>15</td><td>15</td><td>15</td><td>15</td><td>0</td> </tr> </table>	15	15	15	15	15	15	15	15	0	<p><b>User Code 1</b> Location 064 - 071</p> <table border="1"> <tr> <td>2</td><td>5</td><td>8</td><td>0</td><td>15</td><td>15</td><td>15</td><td>8</td> </tr> </table>	2	5	8	0	15	15	15	8	<p><b>User Code 2</b> Location 072 - 079</p> <table border="1"> <tr> <td>15</td><td>15</td><td>15</td><td>15</td><td>15</td><td>15</td><td>15</td><td>0</td> </tr> </table>	15	15	15	15	15	15	15	0
15	15	15	15	15	15	15	15	0																			
2	5	8	0	15	15	15	8																				
15	15	15	15	15	15	15	0																				
<p><b>User Code 6</b> Location 104 - 111</p> <table border="1"> <tr> <td>15</td><td>15</td><td>15</td><td>15</td><td>15</td><td>15</td><td>15</td><td>0</td> </tr> </table>	15	15	15	15	15	15	15	0	<p><b>User Code 4</b> Location 088 - 095</p> <table border="1"> <tr> <td>15</td><td>15</td><td>15</td><td>15</td><td>15</td><td>15</td><td>15</td><td>0</td> </tr> </table>	15	15	15	15	15	15	15	0	<p><b>User Code 5</b> Location 096 - 103</p> <table border="1"> <tr> <td>15</td><td>15</td><td>15</td><td>15</td><td>15</td><td>15</td><td>15</td><td>0</td> </tr> </table>	15	15	15	15	15	15	15	0	
15	15	15	15	15	15	15	0																				
15	15	15	15	15	15	15	0																				
15	15	15	15	15	15	15	0																				
<p><b>User Code 9</b> Location 128 - 135</p> <table border="1"> <tr> <td>15</td><td>15</td><td>15</td><td>15</td><td>15</td><td>15</td><td>15</td><td>0</td> </tr> </table>	15	15	15	15	15	15	15	0	<p><b>User Code 7</b> Location 112 - 119</p> <table border="1"> <tr> <td>15</td><td>15</td><td>15</td><td>15</td><td>15</td><td>15</td><td>15</td><td>0</td> </tr> </table>	15	15	15	15	15	15	15	0	<p><b>User Code 8</b> Location 120 - 127</p> <table border="1"> <tr> <td>15</td><td>15</td><td>15</td><td>15</td><td>15</td><td>15</td><td>15</td><td>0</td> </tr> </table>	15	15	15	15	15	15	15	0	
15	15	15	15	15	15	15	0																				
15	15	15	15	15	15	15	0																				
15	15	15	15	15	15	15	0																				
<p><b>User Code 12</b> Location 152 - 159</p> <table border="1"> <tr> <td>15</td><td>15</td><td>15</td><td>15</td><td>15</td><td>15</td><td>15</td><td>0</td> </tr> </table>	15	15	15	15	15	15	15	0	<p><b>User Code 10</b> Location 136 - 143</p> <table border="1"> <tr> <td>15</td><td>15</td><td>15</td><td>15</td><td>15</td><td>15</td><td>15</td><td>0</td> </tr> </table>	15	15	15	15	15	15	15	0	<p><b>User Code 11</b> Location 144 - 151</p> <table border="1"> <tr> <td>15</td><td>15</td><td>15</td><td>15</td><td>15</td><td>15</td><td>15</td><td>0</td> </tr> </table>	15	15	15	15	15	15	15	0	
15	15	15	15	15	15	15	0																				
15	15	15	15	15	15	15	0																				
15	15	15	15	15	15	15	0																				
<p><b>User Code 15</b> Location 176 - 183</p> <table border="1"> <tr> <td>15</td><td>15</td><td>15</td><td>15</td><td>15</td><td>15</td><td>15</td><td>0</td> </tr> </table>	15	15	15	15	15	15	15	0	<p><b>User Code 13</b> Location 160 - 167</p> <table border="1"> <tr> <td>15</td><td>15</td><td>15</td><td>15</td><td>15</td><td>15</td><td>15</td><td>0</td> </tr> </table>	15	15	15	15	15	15	15	0	<p><b>User Code 14</b> Location 168 - 175</p> <table border="1"> <tr> <td>15</td><td>15</td><td>15</td><td>15</td><td>15</td><td>15</td><td>15</td><td>0</td> </tr> </table>	15	15	15	15	15	15	15	0	
15	15	15	15	15	15	15	0																				
15	15	15	15	15	15	15	0																				
15	15	15	15	15	15	15	0																				
<p><b>User Code 18</b> Location 200 - 207</p> <table border="1"> <tr> <td>15</td><td>15</td><td>15</td><td>15</td><td>15</td><td>15</td><td>15</td><td>0</td> </tr> </table>	15	15	15	15	15	15	15	0	<p><b>User Code 16</b> Location 184 - 191</p> <table border="1"> <tr> <td>15</td><td>15</td><td>15</td><td>15</td><td>15</td><td>15</td><td>15</td><td>0</td> </tr> </table>	15	15	15	15	15	15	15	0	<p><b>User Code 17</b> Location 192 - 199</p> <table border="1"> <tr> <td>15</td><td>15</td><td>15</td><td>15</td><td>15</td><td>15</td><td>15</td><td>0</td> </tr> </table>	15	15	15	15	15	15	15	0	
15	15	15	15	15	15	15	0																				
15	15	15	15	15	15	15	0																				
15	15	15	15	15	15	15	0																				
<p><b>User Code 21</b> Location 224 - 231</p> <table border="1"> <tr> <td>15</td><td>15</td><td>15</td><td>15</td><td>15</td><td>15</td><td>15</td><td>0</td> </tr> </table>	15	15	15	15	15	15	15	0	<p><b>User Code 19</b> Location 208 - 215</p> <table border="1"> <tr> <td>15</td><td>15</td><td>15</td><td>15</td><td>15</td><td>15</td><td>15</td><td>0</td> </tr> </table>	15	15	15	15	15	15	15	0	<p><b>User Code 20</b> Location 216 - 223</p> <table border="1"> <tr> <td>15</td><td>15</td><td>15</td><td>15</td><td>15</td><td>15</td><td>15</td><td>0</td> </tr> </table>	15	15	15	15	15	15	15	0	
15	15	15	15	15	15	15	0																				
15	15	15	15	15	15	15	0																				
15	15	15	15	15	15	15	0																				
<p><b>User Code 22</b> Location 232 - 239</p> <table border="1"> <tr> <td>15</td><td>15</td><td>15</td><td>15</td><td>15</td><td>15</td><td>15</td><td>0</td> </tr> </table>	15	15	15	15	15	15	15	0	<p><b>User Code 23</b> Location 240 - 247</p> <table border="1"> <tr> <td>15</td><td>15</td><td>15</td><td>15</td><td>15</td><td>15</td><td>15</td><td>0</td> </tr> </table>	15	15	15	15	15	15	15	0										
15	15	15	15	15	15	15	0																				
15	15	15	15	15	15	15	0																				

**User Code 24** Location 248 - 255  

15	15	15	15	15	15	15	15	0
----	----	----	----	----	----	----	----	---

**User Code 25** Location 256 - 263  

15	15	15	15	15	15	15	15	0
----	----	----	----	----	----	----	----	---

**User Code 26** Location 264 - 271  

15	15	15	15	15	15	15	15	0
----	----	----	----	----	----	----	----	---

**User Code 27** Location 272 - 279  

15	15	15	15	15	15	15	15	0
----	----	----	----	----	----	----	----	---

**User Code 28** Location 280 - 287  

15	15	15	15	15	15	15	15	0
----	----	----	----	----	----	----	----	---

**User Code 29** Location 288 - 295  

15	15	15	15	15	15	15	15	0
----	----	----	----	----	----	----	----	---

**User Code 30** Location 296 - 303  

15	15	15	15	15	15	15	15	0
----	----	----	----	----	----	----	----	---

**User Code 31** Location 304 - 311  

15	15	15	15	15	15	15	15	0
----	----	----	----	----	----	----	----	---

**User Code 32** Location 312 - 319  

0	15	15	15	15	15	15	15	1
---	----	----	----	----	----	----	----	---

Location 320 - 327

**Auxiliary Code 1**

15	15	15	15	15	15	15	15	2
----	----	----	----	----	----	----	----	---

Page 101

Location 328 - 335

**Auxiliary Code 2**

15	15	15	15	15	15	15	15	2
----	----	----	----	----	----	----	----	---

Page 101

Location 336 - 337

**Day Alarm Mask**

Location 336

- 1 = Zone 1
- 2 = Zone 2
- 4 = Zone 3
- 8 = Zone 4

Location 337

- 1 = Zone 5
- 2 = Zone 6
- 4 = Zone 7
- 8 = Zone 8

Page 110

1	0
---	---

Location 338

**Code Retries**

6
---

Page 101

Location 339

**EOL Resistor Value**

- 1 = 1K
- 2 = 1K5
- 3 = 2K2
- 4 = 3K3

- 5 = 3K9
- 6 = 4K7
- 7 = 5K6
- 8 = 6K8

- 9 = 10K
- 10 = 12K
- 11 = 22K
- 12 = Reserved

- 13 = Reserved
- 14 = Reserved
- 15 = Split EOL (3K3/6K8)  
For 16 Zone Operation

Page 112

4
---

Location 340 - 467

**Zones**

Page 104

**Zone 1** Location 340 - 347  

2	0	0	0	1	3	0	1
---	---	---	---	---	---	---	---

**Zone 2** Location 348 - 355  

1	0	0	0	1	3	0	1
---	---	---	---	---	---	---	---

**Zone 3** Location 356 - 363  

1	0	0	0	1	3	0	1
---	---	---	---	---	---	---	---

**Zone 4** Location 364 - 371  

1	0	0	0	1	3	0	1
---	---	---	---	---	---	---	---

**Zone 5** Location 372 - 379  

1	0	0	0	1	3	0	1
---	---	---	---	---	---	---	---

**Zone 6** Location 380 - 387  

0	0	0	0	1	3	0	1
---	---	---	---	---	---	---	---

**Zone 7** Location 388 - 395  

0	0	0	0	1	3	0	1
---	---	---	---	---	---	---	---

**Zone 8** Location 396 - 403  

12	0	0	0	1	3	3	1
----	---	---	---	---	---	---	---

**Zone 9** Location 404 - 411  

0	0	0	0	1	3	0	1
---	---	---	---	---	---	---	---

**Zone 10** Location 412 - 419  

0	0	0	0	1	3	0	1
---	---	---	---	---	---	---	---

**Zone 11** Location 420 - 427  

0	0	0	0	1	3	0	1
---	---	---	---	---	---	---	---

**Zone 12** Location 428 - 435  

0	0	0	0	1	3	0	1
---	---	---	---	---	---	---	---

**Zone 13** Location 436 - 443  

0	0	0	0	1	3	0	1
---	---	---	---	---	---	---	---

**Zone 14** Location 444 - 451  

0	0	0	0	1	3	0	1
---	---	---	---	---	---	---	---

**Zone 15** Location 452 - 459  

0	0	0	0	1	3	0	1
---	---	---	---	---	---	---	---

**Zone 16** Location 460 - 467  

0	0	0	0	1	3	0	1
---	---	---	---	---	---	---	---

--

**Zone Type**

--

**Zone Option**

--

**Zone Pulse Count**

--

**Zone Pulse Count Time**

--

**Event Code Hundreds Digit**

--

**Event Code Tens Digit**

--

**Event Code Units Digit**

--

**Dialler Channel**

Each zone contains eight locations that are divided into two groups of four. The first four locations determine how the zone operates, while the second four locations contain the dialler reporting information.

**Zone Types**

There are fifteen different zone types to choose from. Each zone can be programmed as any one of the zone types listed in the table below.

<b>Zone Type</b>	<b>Description</b>	<b>Zone Type</b>	<b>Description</b>
0	Instant	8	Delay-1 + Isolated In STAY Mode 1
1	Handover	9	Delay-2 + Isolated In STAY Mode 1
2	Delay-1	10	Delay-3 + Isolated In STAY Mode 1
3	Delay-2	11	Delay 4 + Isolated In STAY Mode 1
4	Delay-3	12	24 Hour Burglary
5	Delay-4	13	24 Hour Fire
6	Instant + Isolated In STAY Mode 1	14	Chime Only
7	Handover + Isolated In STAY Mode 1	15	Zone Not Used

**Zone Options**

<b>Zone Option</b>	<b>Description</b>
1	Lockout Siren
2	Lockout Dialler
4	Silent Alarm
8	Sensor Watch

**Zone Pulse Count Settings**

The pulse count settings for each zone can be programmed between 0 - 15.

**Zone Pulse Count Time**

Zone pulse count time is the time frame or period over which the number of pulses must register.

<b>20 ms Loop Response Time Zone Pulse Count Time</b>		<b>150 ms Loop Response Time Zone Pulse Count Time</b>	
0	0.5 Second	8	20 Seconds
1	1 Second	9	30 Seconds
2	2 Seconds	10	40 Seconds
3	3 Seconds	11	50 Seconds
4	4 Seconds	12	60 Seconds
5	5 Seconds	13	90 Seconds
6	10 Seconds	14	120 Seconds
7	15 Seconds	15	200 Seconds

**Zone Descriptions**

Use this table as a reference to indicate what each zone is connected to.

<b>Zone</b>	<b>Description</b>	<b>Zone</b>	<b>Description</b>
1		9	
2		10	
3		11	
4		12	
5		13	
6		14	
7		15	
8		16	

Location 468 - 469

**Bypass Codes (Zones 1 To 8)**

Page 114

9	9
---	---

Location 470 - 471

**Bypass Codes (Zones 9 To 16)**

Page 114

9	9
---	---

Location 472 - 473

**Trouble Codes (Zones 1 To 8)**

Page 115

9	9
---	---

Location 474 - 475

**Trouble Codes (Zones 9 - 16)**

Page 115

9	9
---	---

Location 476 - 479

**Codepad Duress**

Page 116

1	2	1	1
---	---	---	---

Location 480 - 483

**Codepad Panic**

Page 117

1	2	0	1
---	---	---	---

Location 484 - 487

**Access Denied (Code Retries)**

Page 118

4	2	1	1
---	---	---	---

Location 488 - 491

**AC Fail**

Page 118

3	0	1	1
---	---	---	---

Location 492 - 495

**Low Battery**

Page 119

3	0	9	1
---	---	---	---

Location 496 - 499

**Program Altered Code**

Page 119

3	0	6	0
---	---	---	---

Location 500 - 503 (Software Version 1.10 - 1.31 Only)

**Sensor Trouble (Sensor Watch)**

Page 120

3	8	3	1
---	---	---	---

Location 500 - 503 (New - Software Version 1.32 Onwards)

**Sensor Trouble (Sensor Watch)**

Page 120

3	0	7	1
---	---	---	---

Location 504 - 505

**Open/Close**

Page 120

8	9
---	---

Location 506 - 513

**Test Reporting Time**

Page 122

0	0	0	0	0	0	0	9	0
---	---	---	---	---	---	---	---	---

Location 514 - 529

**Pager Network Password**

Page 87

7	0	6	1	7	3	7	3	7	7	6	4	0	0	0	0
---	---	---	---	---	---	---	---	---	---	---	---	---	---	---	---

Location 530 - 539

**Pager ID Number**

Page 88

0	0	0	0	0	0	0	0	0	0	0
---	---	---	---	---	---	---	---	---	---	---

**Output Configurations**

		Location 540 - 545	<b>Output 1</b>	0 0 0 0 0 0	<b>Output 2</b>	0 0 0 0 0 0
		Location 546 - 551				
<b>Output 3</b>	Location 552 - 557		<b>Strobe</b>	2 0 1 0 0 0	<b>Relay</b>	1 15 1 0 0 0
		Location 558 - 563				
<b>Codepad</b>	Location 570 - 575		<b>Output 7</b>	5 2 6 3 1 0	<b>Output 8</b>	5 2 6 3 6 0
		Location 576 - 581				
<b>Output 9</b>	Location 588 - 593		<b>Output 10</b>	5 3 6 3 6 0	<b>Output 11</b>	5 4 6 3 1 0
		Location 594 - 599				
<b>Output 12</b>	Location 606 - 611		<b>Output 13</b>	5 5 6 3 1 0	<b>Output 14</b>	5 5 6 3 6 0
		Location 612 - 617				
		Location 618 - 623				

Location 624 - 625				Page 140
<b>Entry Timer 1</b>	Location 624 Location 625	Increments Of 1 Second (0 - 15 Sec's) Increments Of 16 Seconds (0 - 240 Sec's)		10 0

Location 626 - 627				Page 140
<b>Entry Timer 2</b>	Location 626 Location 627	Increments Of 1 Second (0 - 15 Sec's) Increments Of 16 Seconds (0 - 240 Sec's)		4 1

Location 628 - 629				Page 140
<b>Entry Timer 3</b>	Location 628 Location 629	Increments Of 1 Second (0 - 15 Sec's) Increments Of 16 Seconds (0 - 240 Sec's)		14 1

Location 630 - 631				Page 140
<b>Entry Timer 4</b>	Location 630 Location 631	Increments Of 1 Second (0 - 15 Sec's) Increments Of 16 Seconds (0 - 240 Sec's)		8 2

Location 632 - 633				Page 141
<b>Exit Time For AWAY Mode</b>	Location 632 Location 633	Increments Of 1 Second (0 - 15 Sec's) Increments Of 16 Seconds (0 - 240 Sec's)		12 3

Location 634 - 635				Page 141
<b>Exit Time For STAY Mode 1</b>	Location 634 Location 635	Increments Of 1 Second (0 - 15 Sec's) Increments Of 16 Seconds (0 - 240 Sec's)		12 3

Location 636 - 637				Page 141
<b>Exit Time For STAY Mode 2</b>	Location 636 Location 637	Increments Of 1 Second (0 - 15 Sec's) Increments Of 16 Seconds (0 - 240 Sec's)		12 3

Location 638 - 639				Page 141
<b>Entry Guard Time For STAY Mode</b>	Location 638 Location 639	Increments Of 1 Second (0 - 15 Sec's) Increments Of 16 Seconds (0 - 240 Sec's)		12 3

Location 640 - 641				Page 142
<b>Codepad Lockout Time</b>	Location 640 Location 641	Increments Of 1 Second (0 - 15 Sec's) Increments Of 16 Seconds (0 - 240 Sec's)		0 0

Location 642 - 643				Page 142
<b>Sensor Watch Time</b>	Location 642 Location 643	Increments Of Days (Tens Digit) Increments Of Days (Units Digit)		0 0

Location 644 - 649 (Software Version 1.10 Only)				Page 143
<b>System Date</b>	Location 644 Location 645 Location 646 Location 647 Location 648 Location 649	Day Of The Week (Sun = 1 Sat = 7) Month Of The Year (Jan = 1 Dec = 12) Day Of The Month (Tens Digit) Day Of The Month (Units Digit) Current Year (Tens Digit) Current Year (Units Digit)		1 1 0 1 9 5

Location 644 - 649 (New - Software Version 1.20 Onwards)				Page 143
<b>System Date</b>	Location 644 Location 645 Location 646 Location 647 Location 648 Location 649	Day Of The Month (Tens Digit) Day Of The Month (Units Digit) Month Of The Year (Tens Digit) Month Of The Year (Units Digit) Current Year (Tens Digit) Current Year (Units Digit)		0 1 0 1 9 5

Location 650 - 653

Page 144

**Auto Arming Time**

Location 650 Hour Of The Day (Tens Digit)  
 Location 651 Hour Of The Day (Units Digit)  
 Location 652 Minute Of The Day (Tens Digit)  
 Location 653 Minute Of The Day (Units Digit)

0	0	0	0
---	---	---	---

Location 654

Page 144

**Pre Arming Alert Time**

Location 654 Increments Of Minutes (0-15)

5
---

Location 655

Page 145

**Pre Alert Time For Timed Output**

Location 655 Increments Of Minutes (0-15)

5
---

Location 656 - 659

Page 145

**Auto Operation Of Timed Output**

Location 656 Hour Of The Day (Tens Digit)  
 Location 657 Hour Of The Day (Units Digit)  
 Location 658 Minute Of The Day (Tens Digit)  
 Location 659 Minute Of The Day (Units Digit)

0	0	0	0
---	---	---	---

Location 660

Page 145

**Siren Run Time**

Location 660 Increments Of Minutes (0-15)

10
----

Location 661

**Siren Sound Rate (Slow <-Sound-> Fast)**

7
---

Location 662 - Software Version 1.10 - 1.37 Only

Page 146

**Swinger Shutdown Count For Siren and Dialler**

0
---

Location 662 (New - Software Version 1.40 Onwards)

Page 147

**Swinger Shutdown Count For Siren**

0
---

Location 663

Page 150

**Dialler Options 1**

1 = Enable Dialler Reporting Functions  
 2 = Enable Remote Arming Via The Telephone  
 4 = Enable Upload/Download Via Alarm Link  
 8 = Terminate "Alarm Link" Session On Alarm

5
---

Location 664

Page 151

**Dialler Options 2**

1 = Send Open/Close Reports Only If A Previous Alarm Has Occurred  
 2 = Enable First To Open/Last To Close Reporting (Partitioned Systems Only)  
 4 = Send Open/Close Reports When In STAY Mode  
 8 = Enable Answering Machine Bypass Only When System Is Armed  
**(New - Software Version 1.31 Onwards)**

0
---

Location 665

Page 152

**System Options 1**

1 = Enable Forced Arming  
 2 = Enable EDM Smart Lockout  
 4 = Enable Monitoring Of Horn Speaker  
 8 = Enable Horn Speaker Beeps For Remote Control Operation

1
---

Location 666

Page 153

**System Options 2**

1 = Enable Radio Key/Keyswitch Interface Or Night Arm Station  
 2 = Enable Handover Delay To Be Sequential  
 4 = Enable Codepad Panic To Be Silent  
 8 = Enable Codepad Tamper To Be Silent

2
---

Location 667

Page 154

**System Options 3**

1 = Enable The Main Codepad To Display Data For Area #1  
 2 = Enable External Modem Module For Alarm Link Operation  
 4 = Enabled = AC Fail In One Hour, Disabled = AC Fail In Two Minutes  
 8 = Enable Pulse Count Handover

0
---

Location 668 (Software Version 1.10 Only)

Page 155

**System Options 4**

1 = Delay Siren Until Transmission Is Complete  
 2 = Enable Resetting Of Sirens From All Areas (Partitioned Systems Only)  
 4 = Enable Auto Arming In AWAY Mode  
 8 = Enable Auto Arming In STAY Mode

0
---

Location 668 (New - Software Version 1.20 Onwards)

Page 156

**System Options 4**

1 = Delay Siren Until Transmission Is Complete  
 2 = Enable Resetting Of Sirens From All Areas (Partitioned Systems Only)  
 4 = Ignore AC Mains Fail **(New - Software Version 1.30 Onwards)**  
 8 = Enable Auto Arming In STAY Mode

0
---

Location 669 (Software Version 1.10 Only)

Page 157

**Consumer Options 1**

- 1 = Enable Entry Guard Delay In STAY Mode
- 2 = Enable Operation Of Sirens & Strobe In STAY Mode
- 4 = Code Only To Isolate
- 8 = Enable Codepad Extinguish Mode

2

Location 669 (New - Software Version 1.20 Onwards)

Page 158

**Consumer Options 1**

- 1 = Enable The STAY LED To Display Day Alarm ON/OFF State
- 2 = Enable Operation Of Sirens & Strobe In STAY Mode
- 4 = Partitioned Codepad - AUX LED To Display Telephone Line In Use
- 8 = Enable Codepad Extinguish Mode

2

Location 670

Page 159

**Consumer Options 2**

- 1 = Enable "User Code + 0 + AWAY" Function To Arm/Disarm All Areas
- 2 = Enable Single Button Arming In AWAY, STAY Mode 1 and STAY Mode 2
- 4 = Enable Single Button Disarming From STAY Mode 1 and STAY Mode 2
- 8 = Enable Alarm Memory Reset On Disarm

2

Location 671

Page 160

**DTMF Command Module Options**

- 1 = Enable Access Into Installer's Programming Mode
- 2 = Enable Access To Installer Code Functions
- 4 = Enable Disarming Of System Via User Codes and Auxiliary Code Operations
- 8 = Enable Access To Master Code Functions

0

Location 672 (Software Version 1.10 Only)

Page 161

**Expansion Board Type**

- 1 = Eight Zone Expansion Board
- 2 = Eight Channel Output Board
- 4 = Momentary Keyswitch Input
- 8 = Latching Keyswitch Input

0

Location 672 (New - Software Version 1.20 Onwards)

Page 162

**Expansion Board Type**

- 1 = Eight Zone Expansion Board
- 2 = Eight Channel Output Board
- 3 = Momentary Keyswitch Input
- 4 = Latching Keyswitch Input
- 5 = Momentary Arm In AWAY Mode
- 6 = Momentary Arm In STAY Mode
- 7 = Momentary Arm In STAY Mode 2
- 8 = Momentary Disarm
- 9 = Momentary Arm Area 4
- 10 = Momentary Disarm Area 4
- 11 = Momentary Arm/Disarm Area 4
- 12 = Latching Arm/Disarm Area 4

0

Location 673

Page 164

**Telephone Line Fault Options**

- 1 = Operate The FAULT Indicator When Telephone Line Fails
  - 2 = Sound Speaker, Bell & Strobe When System Is Armed
  - 4 = Sound Speaker, Bell & Strobe When System Is Disarmed
- Note: Options 2 and 4 Must Be Used In Conjunction With Option 1 (EG: Program a 1, 3 or 5)

0

Location 674 - 675

Page 174

**Open/Close Code For Area 2**

0 0

Location 676 - 677

Page 174

**Open/Close Code For Area 3**

0 0

Location 678 - 679

Page 174

**Open/Close Code For Area 4**

0 0

Location 680 - 683

Page 175

**Subscriber ID Number For Area 2**

0 0 0 0

Location 684 - 687

Page 175

**Subscriber ID Number For Area 3**

0 0 0 0

Location 688 - 691

Page 175

**Subscriber ID Number For Area 4**

0 0 0 0



Location 692 - 699

Page 176

**Zone Allocations For Area 1**

0	0	0	0	0	0	0	0	0
---	---	---	---	---	---	---	---	---

Location 700 - 707

Page 176

**Zone Allocations For Area 2**

0	0	0	0	0	0	0	0	0
---	---	---	---	---	---	---	---	---

Location 708 - 715

Page 177

**Zone Allocations For Area 3**

0	0	0	0	0	0	0	0	0
---	---	---	---	---	---	---	---	---

Location 716 - 723

Page 177

**Zone Allocations For Area 4**

0	0	0	0	0	0	0	0	0
---	---	---	---	---	---	---	---	---

Location 724 - 755

Page 178

**User Code Allocations**

Location 724  
**Areas For User #1**

Location 725  
**Areas For User #2**

Location 726  
**Areas For User #3**

Location 727  
**Areas For User #4**

Location 728  
**Areas For User #5**

Location 729  
**Areas For User #6**

Location 730  
**Areas For User #7**

Location 731  
**Areas For User #8**

Location 732  
**Areas For User #9**

Location 733  
**Areas For User #10**

Location 734  
**Areas For User #11**

Location 735  
**Areas For User #12**

Location 736  
**Areas For User #13**

Location 737  
**Areas For User #14**

Location 738  
**Areas For User #15**

Location 739  
**Areas For User #16**

Location 740  
**Areas For User #17**

Location 741  
**Areas For User #18**

Location 742  
**Areas For User #19**

Location 743  
**Areas For User #20**

Location 744  
**Areas For User #21**

Location 745  
**Areas For User #22**

Location 746  
**Areas For User #23**

Location 747  
**Areas For User #24**

Location 748  
**Areas For User #25**

Location 749  
**Areas For User #26**

Location 750  
**Areas For User #27**

Location 751  
**Areas For User #28**

Location 752  
**Areas For User #29**

Location 753  
**Areas For User #30**

Location 754  
**Areas For User #31**

Location 755  
**Areas For User #32**

Location 756

Page 89

**Printer Output Baud Rate**

- 1 = 300 Baud
- 2 = 600 Baud
- 3 = 1200 Baud
- 4 = 2400 Baud

2

Location 757 (New - Software Version 1.40)

Page 147

**Swinger Shutdown Count For Dialler**

0

Location 760 – 763 (New - Software Version 2.00)

Page 121

**Safecom - RF Fail**

- Location 758 Event Code – Hundreds Digit
- Location 759 Event Code – Tens Digit
- Location 760 Event Code – Units Digit
- Location 761 Dialler Channel

3 5 3 1

Location 764 – 767 (New - Software Version 2.00)

Page 121

**Safecom - Telco Fail**

- Location 764 Event Code – Hundreds Digit
- Location 765 Event Code – Tens Digit
- Location 766 Event Code – Units Digit
- Location 767 Dialler Channel

3 5 1 1

Location 768 – 771 (New - Software Version 2.00)

Page 121

**Safecom - RF Jamming**

- Location 764 Event Code – Hundreds Digit
- Location 765 Event Code – Tens Digit
- Location 766 Event Code – Units Digit
- Location 767 Dialler Channel

3 4 4 1

Location 772 (New - Software Version 2.00 Onwards)

Page 142

**Safecom - RF Jamming Delay**

- Location 772 Increments Of Minutes (0 – 15 Min's)

6

Location 773 (New - Software Version 2.02 Onwards)

Page 142

**Safecom - RF Supervision Time**

- Location 773 Increments Of Minutes (0 – 15 Min's)

10

Location 896 (New - Software Version 2.00 Onwards)

Page 165

**Safecom Reporting Options**

- 1 = Disable Safecom Communication Reporting
- 2 = Enable Remote Arming Via ST1000 Base
- 4 = Enable Remote Disarming Via ST1000 Base
- 8 = Reserved

6

Location 897 (New - Software Version 1.37 onwards)

Page 165

**System Options 5**

- 1 = Enable - Send "Test" Report After Siren Reset
- 2 = Enable Control Panel To Power Up In Disarmed State
- 4 = Enable Internal Crystal To Keep Time (New - Software Version 1.40)
- 8 = Reserved

0

Location 898 (New - Software Version 1.33 Onwards)

Page 166

**System Options 6**

- 1 = Enable Busy Tone Detection For Domestic Dialling
- 2 = Enable "Kiss-Off" Detection For Domestic Dialling
- 4 = Extend Acknowledge Tone Detection From 30 - 60 Seconds
- 8 = If Battery Has Failed, Enable Dynamic Battery Test Only On Arming (New - Software Version 1.35 Onwards)

3

Location 899

Page 167

**Carrier Sync Options**

- 1 = 100 ms
- 2 = 200 ms
- 3 = 300 ms
- 4 = 400 ms
- 5 = 500 ms
- 6 = 600 ms
- 7 = 700 ms
- 8 = 800 ms
- 9 = 900 ms
- 10 = 1 Second
- 11 = 1.1 Seconds
- 12 = 1.2 Seconds
- 13 = 1.3 Seconds
- 14 = 1.4 Seconds
- 15 = 1.5 Seconds

9

Location 900

Page 29

**Disable Factory Default**

- 0 = Defaulting Enabled
- 15 = Defaulting Disabled

0

Location 901 - 904

Page 148

**System Time**

- Location 901 Hour Of The Day (Tens Digit)
- Location 902 Hour Of The Day (Units Digit)
- Location 903 Minute Of The Day (Tens Digit)
- Location 904 Minute Of The Day (Units Digit)

0 0 0 0

# ***Index***

---

**2**

2 Wire Smoke Detector Interface .....	187
24 Hour Fire Zone .....	106
24 Hour Zone.....	106

**A**

AC Fail .....	43, 118
In 1 Hour.....	154
In 2 Minutes.....	154
AC Mains	
Ignore.....	156
Access Denied .....	118
Acknowledge Tone	
Extend Detection From 30 To 60 Seconds .....	166
Alarm Link.....	69, 150
Modem Module .....	154
Terminate On Alarm.....	150
Alarm Link Software .....	185
Alarm Memory Reset On Disarm .....	159
Answering Machine Bypass.....	96, 151, 173
Only When Armed.....	151, 173
Appendices .....	203
Area 1 Codepad Data.....	154
Area Display Indicators .....	170
Area On/Off Indicators.....	170
Arming	
All Areas At Same Time.....	50, 60, 159
Auto Arm In AWAY Mode .....	155
Auto Arm In STAY Mode 1 .....	155, 156
Automatic .....	144
AWAY Mode.....	35, 61
Enable Single Button Arming.....	159
Latching Input For Arm/Disarm In AWAY Mode.....	161, 163
Momentary Input Arm/Disarm In AWAY Mode.....	161, 162
Pre-Alert (Automatic Arm) .....	144
STAY Mode 1 .....	36
STAY Mode 2 .....	38
Via Telephone.....	66
ASCII Characters.....	87
Converting To Hexadecimal.....	88
Audible Indicators .....	33
Auto Arming.....	144
Auto Arming Pre-Alert Timer.....	144
Auto Operation Of The Timed Output.....	145
Auto Operation Pre-Alert Timer.....	145
Automatic Stepping Of Locations.....	28
AUX Indicator .....	171
Display When Telephone Line In Use .....	158
Auxiliary Code 1.....	101
Auxiliary Code 2.....	101
Auxiliary Codes .....	52, 101
Output Event Type.....	131
AWAY Indicator .....	32, 34
AWAY Mode	
Automatic Arm .....	155
Enable Single Button Arming.....	159
Latching Input.....	161, 163
Momentary Input .....	161, 162

**B**

Base Station Information	
Dialling Format .....	93
Handshake Tone.....	94
Primary Telephone Number .....	92
Programming Telephone Numbers.....	92
Secondary Telephone Number .....	93
Subscriber ID Number .....	96
Transmission Format.....	94
Transmission Speed.....	95
Basic Pager.....	84
Battery Test	
Only On Arming.....	166
Bell Test.....	62
Busy Tone Detection For Domestic Dialling .....	166
Bypass Report .....	114

**C**

Call Back Telephone Number .....	93
Carrier Sync Options.....	167
Cellular Dialler.....	186
Chime	
Output.....	106
Zone Type .....	106
Code Retries.....	101
Codepad	
CP5 Eight / Sixteen Zone LCD .....	34
CP5 Eight Zone LED .....	32
Duress Alarm.....	40
Duress Report.....	116
Extinguish Mode .....	157, 158
Fire Alarm .....	40
ID and Buzzer Tone Change .....	64
Lockout Time .....	142
Medical Alarm .....	40
Panic Alarm.....	40
Panic Report.....	117
Panic To Be Silent.....	153
Tamper To Be Silent.....	153
Codepad Indicators	
Audible.....	33
AWAY .....	32, 34
Disarmed .....	34
FAULT.....	33, 34
Isolating Mode .....	34
MAINS.....	33
Off Indicator / Zone Sealed.....	34
On Indicator / Zone In Alarm.....	34
STAY .....	32, 34
ZONES.....	32, 34
Codepads	
Area 1 Codepad As Main Codepad.....	179
Area 1 Codepad Setup.....	179
Area 2 Codepad Setup.....	179
Area 3 Codepad Setup.....	179
Area 4 Codepad Setup.....	179
Master Partitioned Codepad Setup .....	179
Command	
958 - Enable/Disable Zone Status .....	23
959 - Test Programming Key .....	24
960 - Exit Installer's Programming Mode.....	24

961 - Default System.....	24	Busy Tone Detection .....	166
962 - Copy Control Panel To Key.....	25	Disable Via Master Code.....	78
964 - Erase Programming Key.....	26	Kiss Off Detection .....	166
965 - Domestic Dialling.....	27	Operation .....	79
966 - Enable/Disable Automatic Stepping Of Locations.....	28	Program Phone Numbers.....	54, 78
999 - Software Version Number.....	28	DTMF Command Module .....	185
Communications Failure .....	43	Allow Access Into Programming Mode.....	160
Component Overlay .....	198	Allow Access To Installer Code Functions.....	160
Consumer Options 1.....	157, 158	Allow Master Code Functions .....	160
Consumer Options 2.....	159	Arm/Disarm + Auxiliary Code Operations .....	160
Contact ID.....	72	Establish Communication Link.....	22
Event Codes .....	73	Operations .....	67
CP5 Area Addressable Codepad .....	186	Programming .....	22
CP5 Eight Zone Codepad.....	185	Duress	
CP5 Master Partitioned Codepad.....	186	Alarm.....	40
CP5 Sixteen Zone Codepad .....	186	Report.....	116
<b>D</b>		<b>E</b>	
Date and Time.....	42, 58, 143, 148	E2 Fault .....	43
Allow Internal Crystal To Keep Time.....	165	EDMSAT - Satellite Siren.....	127
Day Alarm.....	110	EDMSAT – Satellite Siren .....	184
Enable STAY Indicator To Display Status .....	158	EDMSTU - Securitel Interface .....	184
Latching .....	110	EDMSTU – Securitel Interface .....	127
Operation.....	111	Eight Channel Output Board .....	185, 196
Partitioning.....	111	Eight Zone Expansion Board 3K3 EOL .....	185, 195
Resetting.....	110	Eight Zone Expansion Board Variable EOL .....	185, 195
Turn On/Off.....	58, 62	Entry Guard Timer For STAY Mode .....	141
Default System.....	24, 29	Entry Time.....	140
Delay-1 Zone.....	105	Entry Timer 1 .....	140
Delay-1 Zone + Isolate In STAY 1 .....	105	Entry Timer 2 .....	140
Delay-2 Zone.....	105	Entry Timer 3 .....	140
Delay-2 Zone + Isolate In STAY 1 .....	106	Entry Timer 4 .....	140
Delay-3 Zone.....	105	EOL Resistor Value.....	112
Delay-3 Zone + Isolate In STAY 1 .....	106	Event Codes.....	73, 104
Delay-4 Zone.....	105	Event Memory .....	47
Delay-4 Zone + Isolate In STAY 1 .....	106	Event Memory Recall .....	55
Dialler Amplifier Lead.....	185	Exit Time	
Dialler Options 1 .....	150	AWAY Mode .....	141
Dialler Options 2.....	151, 173	STAY Mode 1 .....	141
Dialler Reporting Functions		STAY Mode 2 .....	141
Enable / Disable .....	150	Expansion Board	
Dialling Format .....	93	Enable 8 Channel Output Board.....	161, 162
Direct Connect .....	69	Enable 8 Zone Expansion Board .....	161, 162
Direct Link Cable.....	185	<b>F</b>	
Disarmed .....	34	Factory Default.....	29
Power Up .....	165	FAULT	
Disarming		AC Mains Fail .....	43
All Areas At Same Time .....	50, 60, 159	Analysis .....	63
Allow Alarm Memory Reset On Disarm .....	159	Analysis Mode.....	42
Enable Single Button Arming .....	159	Communications Fail.....	43
Enable Single Button Disarming.....	159	Date and Time .....	42
From AWAY Mode .....	35	Descriptions.....	42
Latching Input For Arm/Disarm In AWAY Mode161, 163		E2 Fault .....	43
Momentary Input Arm/Disarm In AWAY Mode161, 162		Horn Speaker .....	43
STAY Mode 1 .....	37	Indicator.....	33, 34, 171
STAY Mode 2.....	39	Line Fail.....	43
DMTF Command Module		Low Battery .....	42
Options.....	160	Sensor Watch.....	42
Domestic Dialling .....	27	Zone 16 (Partitioned).....	43
Acknowledge.....	79	Fire Alarm .....	40
		Forced Arming.....	35, 36, 38, 152
		Enable.....	152

**G**  
 Kiss Off Detection For Domestic Dialling ..... 166

**H**  
 General Reporting Formats..... 75

**H**  
 Hand Held Dialler Tester ..... 186  
 Hand Held Programmer ..... 184  
 Handover  
 Sequential Handover..... 153  
 Handover Zone ..... 105  
 Handover Zone + Isolate In STAY 1 ..... 105  
 Handshake Tone ..... 94  
 Hold Down Functions  
 Arm In AWAY Mode ..... 61  
 Arm In STAY Mode 1 ..... 61  
 Arm In STAY Mode 2 ..... 61  
 Bell Test..... 62  
 Codepad ID and Buzzer Tone Change..... 64  
 Fault Analysis ..... 63  
 Horn Speaker Test ..... 61  
 Initiate Modem Call..... 63  
 Initiate Test Report ..... 64  
 Reset Latching Outputs..... 63  
 Strobe Test..... 62  
 Turn Day Alarm On/Off ..... 62  
 Horn Speaker ..... 43  
 Beeps ..... 152  
 Monitor ..... 152  
 Test..... 61

**I**  
 Installer Code..... 98  
 Installer Code Function  
 Event Memory ..... 47  
 Satellite Siren Service Mode..... 48  
 Set First Test Report..... 46  
 Telephone Monitor Mode ..... 49  
 Walk Test..... 48  
 Installer's Programming Command  
 958 - Enable/Disable Zone Status..... 23  
 959 - Test Programming Key..... 24  
 960 - Exit Installer's Programming Mode ..... 24  
 961 - Default System ..... 24  
 962 - Copy Control Panel To Key ..... 25  
 963 - Copy Key To Control Panel ..... 25  
 964 - Erase Programming Key..... 26  
 965 - Domestic Dialling..... 27  
 966 - Automatic Stepping Of Locations ..... 28  
 999 - Software Version Number ..... 28  
 Instant Zone ..... 105  
 Instant Zone + Isolate In STAY 1 ..... 105  
 Introduction ..... 13, 14  
 Isolating Zones  
 Code To Isolate Method ..... 41  
 Enable Code To Isolate..... 157  
 Standard Method..... 41

**J**  
 JP5 Terminal Block ..... 185

**K**  
 Keyswitch Interface  
 Enable..... 153

**L**  
 Latching Input  
 Arm/Disarm Area 4 ..... 163  
 Arm/Disarm AWAY Moder..... 161  
 Arm/Disarm In AWAY Mode ..... 163  
 Latching Outputs ..... 63  
 Lockout  
 Dialler ..... 107  
 Siren ..... 107  
 Low Battery..... 42, 113, 119  
 Dynamic Battery Test Only On Arm..... 166

**M**  
 MAINS Indicator ..... 33, 34, 171  
 Master Code ..... 99  
 Master Code Function  
 Adding / Deleting User Codes..... 51  
 Arm All Areas At Same Time ..... 50  
 Date and Time..... 58  
 Disarm All Areas At Same Time..... 50  
 Event Memory Recall..... 55  
 Program Domestic Phone Numbers ..... 54  
 Program STAY Mode 2 Zones..... 59  
 Turn Day Alarm On/Off..... 58  
 Turn Outputs On / Off..... 57  
 Walk Test ..... 56  
 Master Partitioned Codepad  
 Area Display Indicators..... 170  
 Area On/Off Indicators..... 170  
 AUX Indicator..... 171  
 FAULT Indicator ..... 171  
 MAINS Indicator ..... 171  
 PARTIAL Indicator ..... 171  
 Zone Indicators..... 170  
 Medical Alarm ..... 40  
 Modem Call  
 Initiate ..... 63  
 Modem Module..... 154, 184  
 Momentary Input  
 Arm Area 4 ..... 163  
 Arm In AWAY Mode..... 163  
 Arm In STAY Mode 1 ..... 163  
 Arm In STAY Mode 2 ..... 163  
 Arm/Disarm Area 4 ..... 163  
 Arm/Disarm In AWAY Mode..... 161, 162  
 Disarm Area 4 ..... 163  
 Disarm Only ..... 163  
 Momentary Or Latching Keyswitch ..... 197

**N**  
 Night Arm Station ..... 186  
 Enable ..... 153

**O**  
 Off Indicator / Zone Sealed ..... 34  
 On Indicator / Zone In Alarm..... 34  
 Open/Close Reports ..... 120  
 Area 1 ..... 174  
 Area 2 ..... 174  
 Area 3 ..... 174  
 Area 4 ..... 174

First To Open/Last To Close.....	151, 173	Area 2 Is Disarmed .....	133
In STAY Mode 1.....	151, 173	Area 3 Codepad Data.....	133
In STAY Mode 2.....	151, 173	Area 3 Has Zone Unsealed .....	132
Only If Previous Alarm Occurred .....	151, 173	Area 3 In Alarm.....	132
Optional Equipment		Area 3 Is Armed .....	133
16 Zone LED Codepad.....	186	Area 3 Is Disarmed .....	133
2 Channel Radio Interface (RE005).....	187	Area 4 Codepad Data.....	133
2 Wire Smoke Detector Interface.....	187	Area 4 Has Zone Unsealed .....	132
8 Channel Output Board.....	185	Area 4 In Alarm.....	132
8 Zone Area Codepad.....	186	Area 4 Is Armed .....	133
8 Zone Expansion Board (3K3) .....	185	Area 4 Is Disarmed .....	133
8 Zone Expansion Board (Variable).....	185	Armed In AWAY Mode .....	127
8 Zone LED Codepad.....	185	Armed In STAY Mode.....	127
8 Zone Master Partitioned Codepad.....	186	Auxiliary Code 1 .....	131
Cellular Dialler.....	186	Auxiliary Code 2 .....	131
Codepad Mimic Board .....	187	Chime .....	132
Dialler Amplifier Lead .....	185	Codepad Duress Alarm.....	129
Direct Link Cable .....	185	Codepad Fire Alarm .....	129
EDMSTU .....	184	Codepad Medical Alarm.....	129
Hand Held Dialler Tester .....	186	Codepad Panic Alarm.....	129
Hand Held Programmer .....	184	Codepad Tamper .....	129
JP5 Terminal Block.....	185	Communications Failure.....	131
Modem Module.....	184	Day Alarm Enabled .....	128
Night Arm Station .....	186	Day Alarm Latching .....	128
Phone Controller .....	186	Day Alarm Resetting .....	128
Programming Key .....	184	Dialler Active .....	131
PS100 Power Supply.....	186	Dialler Disabled.....	131
Radio Key/Keypress Interface.....	187	EDMSAT - Satellite Siren.....	127
Relay Output Interface .....	187	EDMSTU - Securitel.....	127
Satellite Siren .....	184	Entry Warning .....	128
Telephone Line Fault Module.....	185	Entry Warning + Day Alarm Resetting.....	128
TF008 Plug Pack.....	186	Exit Warning .....	127
Voice Module.....	184	Exit Warning Finished.....	128
Output 1 .....	125	Exit Warning With All Zones Sealed + Entry Warning .....	127
Output 10 .....	125	Fire Alarm Latching.....	130
Output 11 .....	125	Fire Alarm Resetting.....	130
Output 12 .....	125	Fire Alarm Verification .....	130
Output 13 .....	125	Horn Speaker Fail.....	129
Output 14 .....	125	Kiss-Off After End Of Exit Time .....	128
Output 2 .....	125	Low Battery.....	129
Output 3 .....	125	Mimic Zone 1 .....	132
Output 4 .....	125	Mimic Zone 10 .....	132
Output 5 .....	125	Mimic Zone 11 .....	132
Output 6 .....	125	Mimic Zone 12 .....	132
Output 7 .....	125	Mimic Zone 13 .....	132
Output 8 .....	125	Mimic Zone 14 .....	132
Output 9 .....	125	Mimic Zone 15 .....	132
Output Event Type		Mimic Zone 16 .....	132
AC Fail.....	128	Mimic Zone 2 .....	132
AC Mains 60 Hz Or 50 Hz.....	132	Mimic Zone 3 .....	132
Alarm In AWAY Mode.....	130	Mimic Zone 4 .....	132
Alarm In STAY Mode.....	130	Mimic Zone 5 .....	132
Any Areas Armed.....	133	Mimic Zone 6 .....	132
Any Areas Disarmed .....	133	Mimic Zone 7 .....	132
Area 1 Codepad Data .....	133	Mimic Zone 8 .....	132
Area 1 Has Zone Unsealed.....	132	Mimic Zone 9 .....	132
Area 1 In Alarm .....	132	Pre-Alert Warning For Timed Output.....	128
Area 1 Is Armed .....	133	Pre-Arming Alert Time.....	127
Area 1 Is Disarmed.....	133	Printer .....	127
Area 2 Codepad Data .....	133	Remote Control 1 .....	131
Area 2 Has Zone Unsealed.....	132	Remote Control 2.....	131
Area 2 In Alarm .....	132	Remote Control 3.....	131
Area 2 is Armed .....	133		

Remote Control 4.....	131	DTMF Command Module.....	22
Ring Detect.....	131	Entry/Exit Timers.....	140
Sensor Watch.....	129	Exit.....	24
Silent Alarm.....	130	Hand Held Programmer.....	20
Sirens Running.....	130	Installer's Programming Commands.....	23
Speaker Beeps.....	129	Option Bits.....	22
Strobe Operating.....	130	Outputs.....	124
System Armed.....	127	Programming Key.....	21
System Disarmed.....	127	Telephone Numbers.....	92
Telephone Line Fault.....	131	With Codepad.....	19
Timed Output.....	128	Programming Key.....	24, 184
Zone Not Sealed.....	132	Copy Control Panel To Key.....	25
Zone Not Sealed After Exit Time.....	132	Erase.....	26
Outputs		Programming Mode.....	34
Automatic Operations Time.....	145	Programming Sheets.....	209
Defaults.....	125	PS100 Power Supply Module.....	186
Event Types.....	127	Pulse Count.....	108
One Shot Polarity.....	137	Handover.....	154
Polarity.....	134	Time.....	109
Pre-Alert Timer.....	145		
Pulsing Polarities.....	136	<b>Q</b>	
Redirecting To Codepad Buzzer.....	126	Quick Start.....	15
Timing.....	136		
Toggle On/Off Via Master Code.....	57	<b>R</b>	
<b>P</b>		Radio Key/Keyswitch Interface.....	187
Panic Alarm.....	40	RE005.....	187
Silent.....	153	Enable.....	153
Panic Report.....	117	Receivers and Their Formats.....	95
PARTIAL Indicator.....	171	Remote Operations	
Partitioning.....	170	Arming Via Telephone.....	66, 150
Allow Resetting Of Sirens From All Areas.....	155, 156	DTMF Command Module Operations.....	67
Area 1 Codepad As Main Codepad.....	179	Upload/Download.....	69
Area 1 Codepad Setup.....	179	Reporting Formats	
Area 2 Codepad Setup.....	179	3+1 Format.....	75
Area 3 Codepad Setup.....	179	4+1 Format.....	75
Area 4 Codepad Setup.....	179	4+2 Format.....	75
Area Addressable Codepad Operations.....	171	Basic Pager.....	84
Arm/Disarm All Areas At Same Time.....	159	Contact ID.....	72
Connecting Codepads.....	180	Domestic.....	78
Master Codepad Operations.....	171	PET Alpha Pager.....	85
Master Partitioned Codepad.....	170	Securitel.....	77
Master Partitioned Codepad Setup.....	179	Synthesised Voice Reporting.....	80
Securitel.....	171	Resistor Value.....	112
User Code Allocations.....	178	RF Fail.....	121
Zone Allocations.....	176	RF Jamming.....	121
Patrolman Code.....	99	RF Supervision Time.....	142
PET Alpha Pager		Ring Count.....	96
ID Number.....	88		
Password.....	87	<b>S</b>	
Programming & Hardware Requirements.....	85	Safecom	
Reporting.....	85	Interface.....	199
Reporting Messages.....	86	Remote Arming Via ST1000 Base.....	165
Telecom Access Telephone No's.....	85	Remote Disarming Via ST1000 Base.....	165
Phone Controller.....	186	RF Fail.....	121
Point ID Codes.....	74	RF Jamming.....	121
Power Up Disarmed.....	165	RF Supervision Time.....	142
Primary Telephone Number.....	92	Telco Fail.....	121
Printer Output BAUD Rate.....	89	Satellite Siren.....	127, 184
Program Altered Code.....	119	Service Mode.....	48
Programming.....	18	Secondary Telephone Number.....	93
Disable Factory Default.....	29	Securitel.....	77, 127
Domestic Format.....	78	Partitioning.....	171
		Sensor Watch.....	42, 108, 113, 120



Time .....	142	Arming In STAY Mode 2 .....	38
Sensor Watch Time .....	142	Disarming .....	35
Serial Printer .....	127	Disarming From STAY Mode 1 .....	37
Logging Events .....	89	Disarming From STAY Mode 2 .....	39
Program Output BAUD Rate .....	89	System Options 1 .....	152
Reporting Messages .....	90	System Options 2 .....	153
Wiring Diagram .....	197	System Options 3 .....	154
Silent Alarm .....	107	System Options 4 .....	155, 156
Siren		System Options 5 .....	165
Allow Resetting From All Areas .....	155, 156	System Options 6 .....	166
Delay Until Transmission Complete .....	155, 156	System Status Reports	
Operate In STAY Mode .....	157	AC Fail .....	118
Run Time .....	145	Access Denied .....	118
Sound Rate .....	145	Duress Alarm .....	116
Sirens		Low Battery .....	119
Operate In STAY Mode .....	158	Open/Close Reports .....	120
Smart Lockout .....	152	Panic Alarm .....	117
Software Version Number .....	28, 208	Programming Changed .....	119
Solution Codepad Mimic Board .....	187	RF Fail .....	121
Solution Relay Output Interface .....	187	RF Jamming .....	121
Specifications .....	208	Sensor Watch .....	120
Split EOL Resistors For 16 Zone Operation .....	196	Telco Fail .....	121
Status Indicators .....	170	Tests .....	122
STAY Indicator .....	32, 34	Zone Bypass Report .....	114
STAY Mode 1 .....	36	Zone Trouble .....	115
Arming .....	61		
Automatic Arm .....	155, 156	<b>T</b>	
Disarming .....	37	Telco Fail .....	121
Enable Single Button Arming .....	159	Telecom Connection Diagrams .....	201
Enable Single Button Disarming .....	159	Telepermit Note .....	16
Entry Guard Time .....	157	Telephone Anti-Jamming .....	204
Entry Guard Timer .....	141	Telephone Line Fail .....	43
Momentary Input .....	163	Activate Alarm When Armed .....	164
Single Button Arming/Disarming .....	61	Activate Alarm When Disarmed .....	164
STAY Mode 2		Operate FAULT Indicator .....	164
Arming .....	38, 61	Telephone Line Fault Module .....	185
Disarming .....	39	Telephone Monitor Mode .....	49
Enable Single Button Arming .....	159	Terminal Definitions and Descriptions .....	192
Enable Single Button Disarming .....	159	Termination Block For JP5 Pins (CC882) .....	185
Entry Guard Time .....	157	Test	
Entry Guard Timer .....	141	Programming Key .....	24
Momentary Input .....	163	Test Reports .....	122
Programming Zones .....	59	Initiate .....	64
Single Button Arm/Disarm .....	61	On All Active Diallers (Partitioning) .....	122
Strobe Test .....	62	Only When Armed .....	122, 205
Subscriber ID Number .....	96	Send After Siren Reset .....	165
Area 1 .....	175	Set First Test Report .....	46
Area 2 .....	175	TF008 Plug Pack .....	186
Area 3 .....	175	Transmission Format .....	94
Area 4 .....	175	Transmission Speed .....	95
Swinger Shutdown		Trouble Reports .....	115
Dialler .....	147		
Siren .....	147	<b>U</b>	
Siren/Dialler .....	146	Upload/Download	
Synthesised Voice		Call Back Telephone Number .....	93
Disable Via Master Code .....	81	Direct Connect .....	69
Synthesised Voice Reporting		Enable .....	150
Acknowledge .....	81	Remote Connect .....	70
Operation .....	81	Remote Connect With Callback Verification .....	70
Set Up and Programming Numbers .....	80	Remote Connect With Customer Control .....	70
System Operations		Remote Connect Without Callback Verification .....	70
Arming In AWAY Mode .....	35	Terminate On Alarm .....	150
Arming In STAY Mode 1 .....	36	User Code Function	

Arm/Disarm All Areas At Same Time .....	60	Programming .....	104
User Codes .....	98	Pulse Count .....	104, 108
Adding .....	51	Pulse Count Handover .....	109, 154
Allocations .....	178	Pulse Count Time .....	104, 109
Auxiliary .....	52, 101	Reporting Information .....	104
Deleting .....	52	Trouble Report .....	115
Priority Level .....	99	Types .....	104, 105
<b>V</b>		Zone 16 (Partitioned Systems) .....	43
Voice Module .....	184	Zone Options	
Connection .....	83	Lockout Dialler .....	107
Operation .....	82	Lockout Siren .....	107
Recording Message .....	82	Sensor Watch .....	108
Replaying Message .....	82	Silent Alarm .....	107
<b>W</b>		Zone Status Mode .....	23
Walk Test .....	48, 56	Zone Type	
Warranty Statement .....	208	24-Hour Burglary .....	106
Wiring Diagram .....	194	24-Hour Fire .....	106
<b>Z</b>		Chime .....	106
Zone		Delay-1 .....	105
Allocations .....	176	Delay-1 + Isolated In STAY 1 .....	105
Bypass Report .....	114	Delay-2 .....	105
Defaults .....	104	Delay-2 + Isolated In STAY 1 .....	106
Dialler Channel .....	104	Delay-3 .....	105
EOL Resistor Value .....	112	Delay-3 + Isolated In STAY 1 .....	106
Event Code .....	104	Delay-4 .....	105
Indicator .....	34	Delay-4 + Isolated In STAY 1 .....	106
Indicators .....	32, 170	Handover .....	105
Operating Information .....	104	Handover + Isolated In STAY 1 .....	105
Option .....	104	Instant .....	105
Options .....	107	Instant + Isolated In STAY 1 .....	105
		Not Used .....	106





---

**Electronics Design & Manufacturing Pty Limited**

25 Huntingwood Drive  
Huntingwood NSW 2148  
Australia

A.C.N. 002 907 271

Phone: +612 9672 1777  
Facsimile: +612 9672 1717  
email: [edm@edm.com.au](mailto:edm@edm.com.au)

---